

## 1200V/10A Silicon Carbide Power Schottky Barrier Diode

### Features

- Rated to 1200V at 10 Amps
- Zero reverse recovery current
- Zero forward recovery voltage
- Temperature independent switching behaviour
- High temperature operation
- High frequency operation

Key Characteristics		
$V_{RRM}$	<b>1200</b>	<b>V</b>
$I_F, T_c \leq 165^\circ\text{C}$	<b>5*</b>	<b>A</b>
$Q_c$	<b>36*</b>	<b>nC</b>

(\*: for per leg ; \*\*:for both legs)

### Benefits

- Unipolar rectifier
- Substantially reduced switching losses
- No thermal run-away with parallel devices
- Reduced heat sink requirements

### Applications

- SMPS, e.g., CCM PFC;
- Motor drives, Solar application, UPS, Wind turbine, Rail traction, EV/HEV

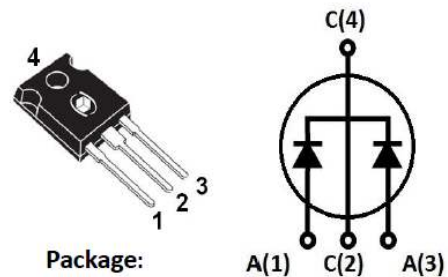

Part No.	Package Type	Marking
G3S12010B	TO-247AB	G3S12010B

**Maximum Ratings**

Parameter	Symbol	Test Condition	Value	Unit
Repetitive Peak Reverse Voltage	$V_{RRM}$		1200	V
Surge Peak Reverse Voltage	$V_{RSM}$		1200	V
DC Blocking Voltage	$V_{DC}$		1200	V
Continuous Forward Current	$I_F$	$T_C=25^{\circ}C$ $T_C=125^{\circ}C$ $T_C=165^{\circ}C$	39* 21.5* 5*	A
Repetitive Peak Forward Surge Current	$I_{FRM}$	$T_C=25^{\circ}C$ , $t_p=10ms$ , Half Sine Wave, $D=0.3$	25*	A
Non-repetitive Peak Forward Surge Current	$I_{FSM}$	$T_C=25^{\circ}C$ , $t_p=10ms$ , Half Sine Wave	100*	A
Power Dissipation	$P_{TOT}$	$T_C=25^{\circ}C$	165*	W
		$T_C=110^{\circ}C$	71*	W
Operating Junction	$T_j$		-55°C to 175°C	°C
Storage Temperature	$T_{stg}$		-55°C to 175°C	°C
Mounting Torque		M3 Screw	1	Nm
		6-32 Screw	8.8	lbf-in

**Thermal Characteristics**

Parameter	Symbol	Test Condition	Value	Unit
			Typ.	
Thermal resistance from junction to case	$R_{th\ JC}$		0.91* 0.455**	°C/W

**Electrical Characteristics**(Per leg)

Parameter	Symbol	Test Conditions	Numerical		Unit
			Typ.	Max.	
Forward Voltage	$V_F$	$I_F=5A, T_j=25^\circ C$	1.42	1.7	V
		$I_F=5A, T_j=175^\circ C$	2	2.5	
Reverse Current	$I_R$	$V_R=1200V, T_j=25^\circ C$	10	50	$\mu A$
		$V_R=1200V, T_j=175^\circ C$	20	100	
Total Capacitive Charge	$Q_C$	$V_R=800V, T_j=150^\circ C$ $Q_C = \int_0^{V_R} C(V)dV$	36	-	nC
Total Capacitance	C	$V_R=0V, T_j=25^\circ C, f=1MHz$	475	510	pF
		$V_R=400V, T_j=25^\circ C, f=1MHz$	34	44	
		$V_R=800V, T_j=25^\circ C, f=1MHz$	33	40	

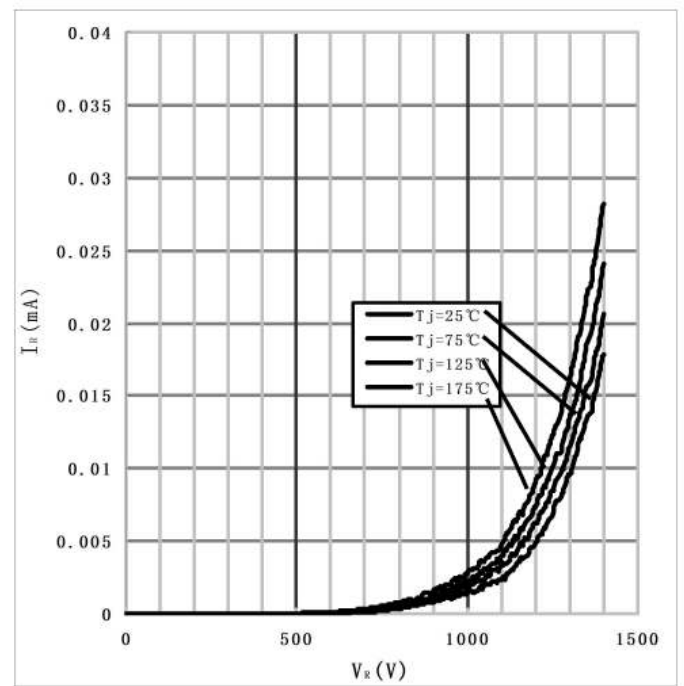
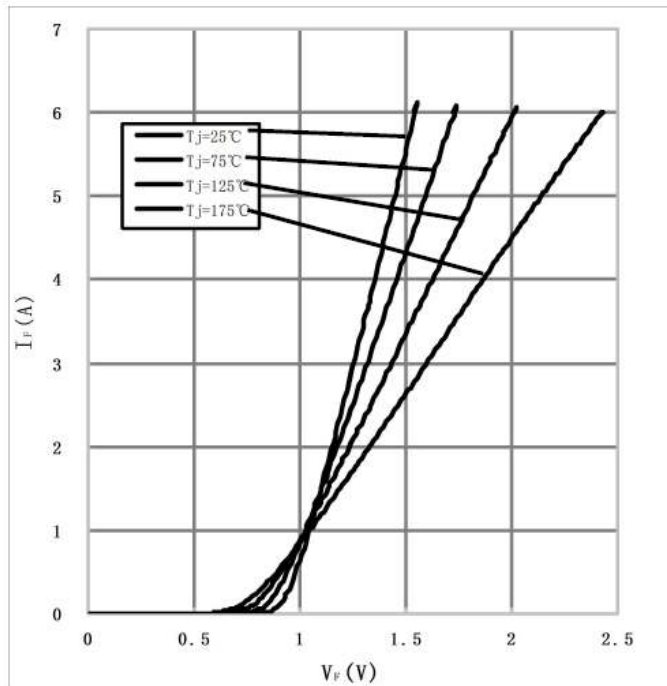
**Performance Graphs**1) Forward IV characteristics as a function of  $T_j$  :2) Reverse IV characteristics as a function of  $T_j$  :

3) Current Derating

4) Capacitance vs. reverse voltage :

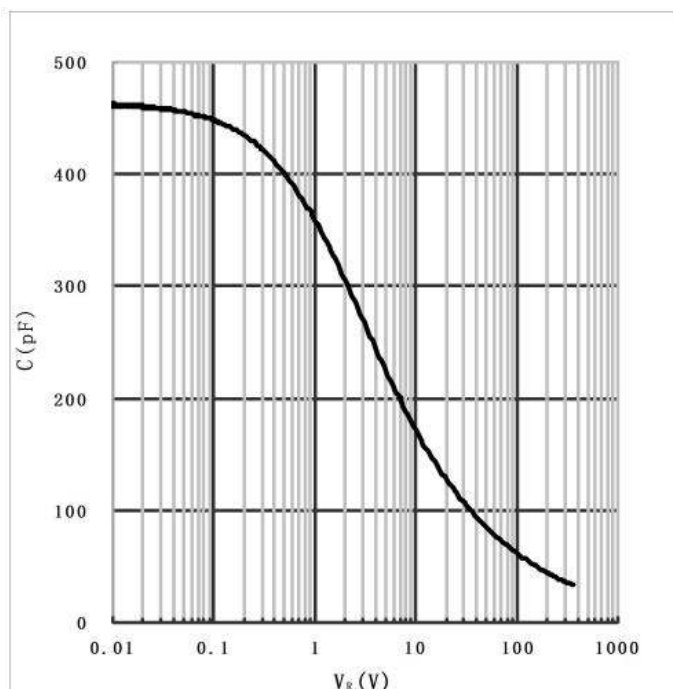
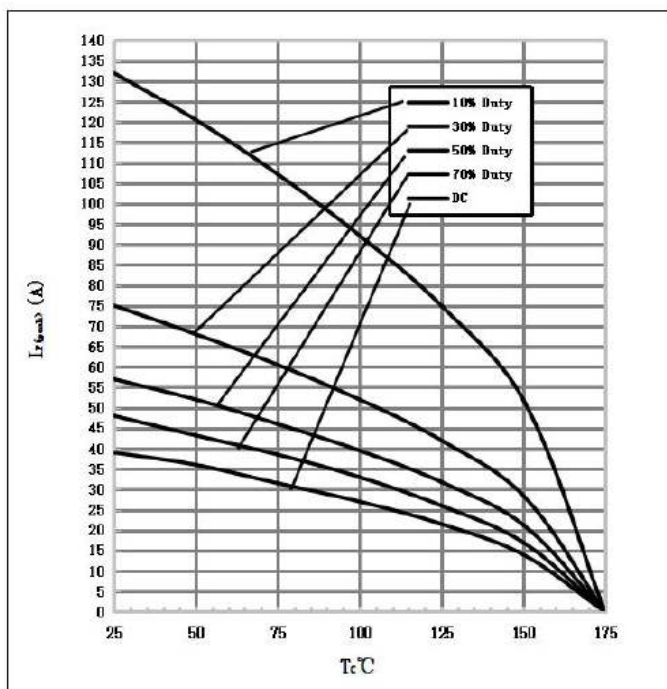

Package TO-247AB

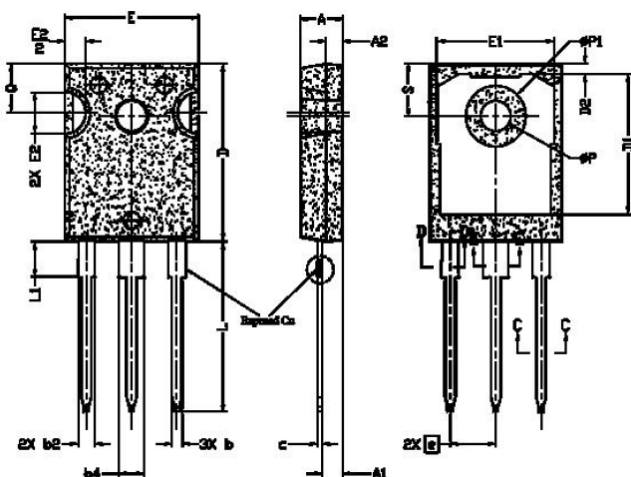

SYMBOL	DIMENSIONS			NOTES
	MIN	NOM	MAX	
A	4.83	5.02	5.21	
A1	2.29	2.41	2.55	
A2	1.50	2.00	2.49	
b	1.12	1.20	1.33	
b1	1.12	1.20	1.28	
b2	1.91	2.00	2.39	6
b3	1.91	2.00	2.34	
b4	2.87	3.00	3.22	6, 8
b5	2.87	3.00	3.18	
c	0.55	0.60	0.69	6
c1	0.55	6.00	0.65	
D	20.80	20.95	21.10	4
D1	16.25	16.55	17.65	5
D2	0.51	1.19	1.35	
E	15.75	15.94	16.13	4
E1	13.46	14.02	14.16	5
E2	4.32	4.91	5.49	3
e	5.44 BSC			
L	19.81	20.07	20.32	
L1	4.10	4.19	4.40	6
ΦP	3.56	3.61	3.65	7
ΦP1	7.19 REF			
Q	5.39	5.79	6.20	
S	6.04	6.17	6.30	

**Note:** The levels of RoHS restricted materials in this product are below the maximum concentration values (also referred to as the threshold limits) permitted for such substances, or are used in an exempted application, in accordance with EU Directive 2011/65/EC(RoHS2). RoHS Certification and other certifications can be obtained from GPT sales representatives or GPT website: <http://globalpowertech.cn/English/index.asp>

**More product datasheets and company information can be found in:**

<http://globalpowertech.cn/English/index.asp>

