

NOTES:

1. $\text{\textcircled{C}}$ REPRESENTS A CRITICAL DIMENSION.
2. MINIMUM CONTACT RETENTION: 12 OZS.
3. MINIMUM LOCKING CLIP RETENTION: 8 OZS.
4. MAXIMUM HEIGHT VARIATION BETWEEN ANY TWO PINS: .005[0.13].
5. MAXIMUM TERMINAL BURR: .003[0.08].
6. COPLANARITY: .004[0.10] = POS 02 THRU 26
.006[0.15] = POS 27 THRU 50. $\text{\textcircled{C}}$
7. MEASURED FROM BEND.
8. MEASURE FROM TIPS OF PIN.
9. SIDES OF PLASTIC BODIES ON ALL LEAD STYLES EXCEPT THE -01 & -02 WILL BE SOLID AND WITHOUT SIDE SLOTS.
10. NOTE DELETED.
11. DUE TO THE HIGH AMOUNT OF INSERTION FORCE NEEDED, THE -LC OPTION IS NOT COMPATIBLE WITH AUTO PLACEMENT. SAMTEC RECOMMENDS MANUAL PLACEMENT FOR ALL ASSEMBLIES WITH THE -LC OPTION.
12. NOTE DELETED.
13. NOT ALL PARTS FOLLOW EIA-481 ORIENTATION IN THE T&R POCKET.
14. NOTE DELETED.
15. NOTE DELETED.
16. TUBE IS STANDARD PACKAGING.
17. ORDERS WILL BE PACKAGED ACCORDING TO THE SAMTEC PACKAGING EFFICIENCY STANDARDS (SPES) FOUND ON WWW.SAMTEC.COM
18. ATTACH LABEL TO EACH REEL.

DO NOT SCALE FROM THIS PRINT

TFC-1XX-XX-XX-D-XX-X-XX

No OF POSITIONS

- LEAD STYLE -01, -02: -02 THRU -50 (ALL POSITIONS AVAILABLE)
LEAD STYLES -11, -12: (-05 THRU -50 MULTIPLES OF 5) POSITIONS -12, -16, -17 ALSO AVAILABLE
LEAD STYLES -21, -22: (-05 THRU -50 MULTIPLES OF 5) POSITIONS -12 & -13 ALSO AVAILABLE
LEAD STYLES -31, -32: (-05 THRU -50 MULTIPLES OF 5) -12 POSITION ALSO AVAILABLE

LEAD STYLE

- | | |
|-----------------|------------------------|
| THROUGH HOLE | SURFACE MOUNT |
| -01 (SEE FIG 1) | -02 (SEE FIG 2, SHT 2) |
| -11 (SEE FIG 1) | -12 (SEE FIG 2, SHT 2) |
| -21 (SEE FIG 1) | -22 (SEE FIG 2, SHT 2) |
| -31 (SEE FIG 1) | -32 (SEE FIG 2, SHT 2) |
- (SEE TABLE 1, SHT 3)

PACKAGING

- BLANK: TUBES (SEE NOTE 16 & 17)
- TR: TAPE AND REEL (SEE FIG 4, SHT 4) (FOR -X2 ONLY) (NOT AVAILABLE WITH -RA) (SEE NOTE 13, 17 & 18)
- FR: FULL REEL QTY. TAPE & REEL (FOR -X2 ONLY) (NOT AVAILABLE WITH -RA) (SEE NOTE 13, 17 & 18)

PICK & PLACE OPTION

- P: PICK AND PLACE PAD (USE PPP-04) (AVAILABLE IN ALL POSITIONS -05 THRU -50) (NOT AVAILABLE WITH -RA) (SEE FIG 7, SHT 3)
- K: POLYIMIDE FILM (SEE FIG 3, SHT 2) (ALL LEAD STYLES EXCEPT -21 AVAILABLE) (NOT AVAILABLE FOR -RA) (USE K-DOT-.217-.313-.005)

OPTION

- A: ALIGNMENT PIN (USE TFM-XX-D-XX-A, SEE TABLE 1, SHT 3) (SEE FIG 5, SHT 3) (NOT AVAILABLE WITH -RA)
- LC: LOCKING CLIP (USE LC-05-TM) (NOT AVAILABLE WITH -RA) (SEE FIG 6, SHT 3, NOTE 3 & 11)
- RA: RIGHT ANGLE (AVAILABLE ONLY IN LEAD STYLE: -01) (SEE FIG 8, SHT 2)

BODY SPECIFICATION

- D: DOUBLE ROW

PLATING SPECIFICATION

- F: 3 μ " FLASH GOLD ON CONTACT AREA, MATTE TIN TAIL
- L: 15 μ " SELECTIVE GOLD ON CONTACT AREA, MATTE TIN TAIL
- LM: 15 μ " SELECTIVE GOLD ON CONTACT AREA, MATTE TIN TAIL
- FM: 3 μ " FLASH GOLD ON CONTACT AREA, MATTE TIN TAIL

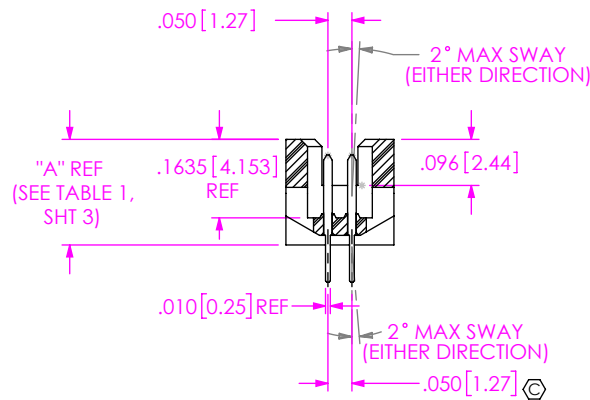
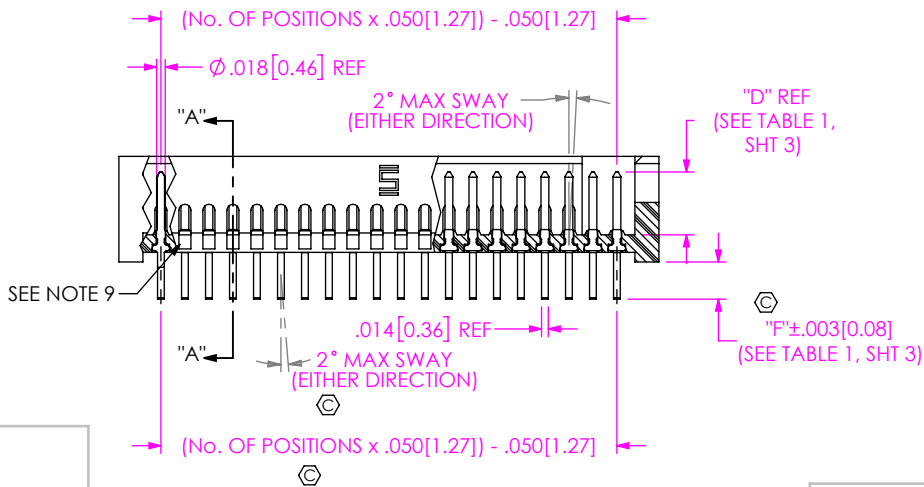
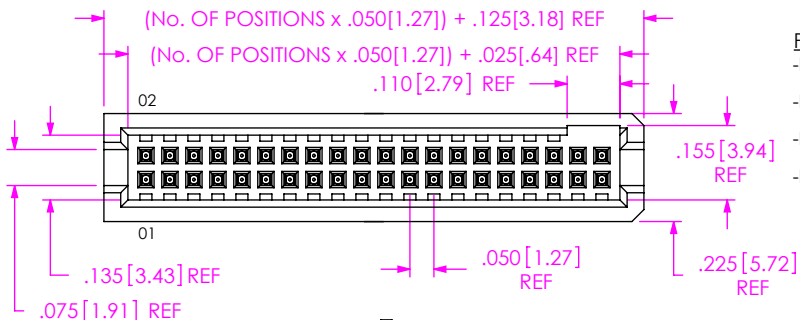

SECTION "A"-A"

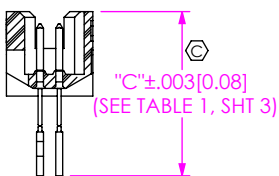

IN-PROCESS

FIG 1 THROUGH HOLE -01, -11, -21, -31

UNLESS OTHERWISE SPECIFIED, DIMENSIONS ARE IN INCHES.
TOLERANCES ARE:
DECIMALS ANGLES
.XX: ±.01 [.3] 2°
.XXX: ±.005 [.13]
.XXXX: ±.0020 [.051]

PROPRIETARY NOTE
THIS DOCUMENT CONTAINS CONFIDENTIAL AND PROPRIETARY INFORMATION AND ALL DESIGN, MANUFACTURING, REPRODUCTION, USE, PATENT RIGHTS AND SALES RIGHTS ARE EXPRESSLY RESERVED BY SAMTEC, INC. THIS DOCUMENT SHALL NOT BE DISCLOSED, IN WHOLE OR PART, TO ANY UNAUTHORIZED PERSON OR ENTITY NOR REPRODUCED, TRANSFERRED OR INCORPORATED IN ANY OTHER PROJECT IN ANY MANNER WITHOUT THE EXPRESS WRITTEN CONSENT OF SAMTEC, INC.



520 PARK EAST BLVD, NEW ALBANY, IN 47150
PHONE: 812-944-6733 FAX: 812-948-5047
e-Mail: info@SAMTEC.com code 55322

MATERIAL: DO NOT SCALE DRAWING SHEET SCALE: 2.5:1
INSULATOR: LCP, UL 94-V0
COLOR: BLACK

TERMINAL: PHOSPHOR BRONZE
F:\DWG\MISC\MKTG\TFC-1XX-XX-XX-D-XX-X-XX-MKT.SLDDRW

DESCRIPTION: .050 X .050 TERMINAL STRIP

DWG. NO. TFC-1XX-XX-XX-D-XX-X-XX

BY: BRATCHER 05/25/2001 SHEET 1 OF 4

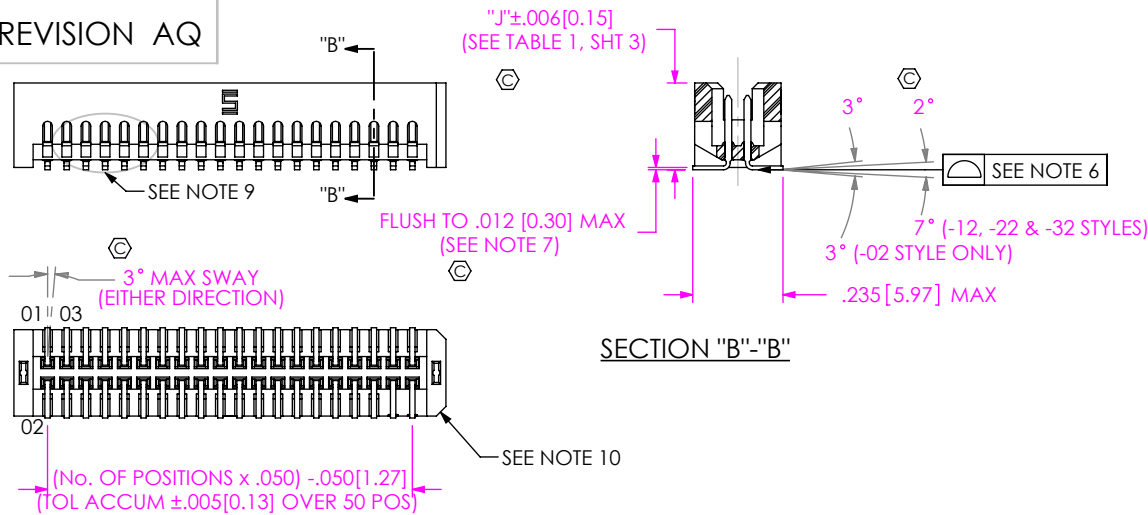

FIG 2
SURFACE MOUNT
-02, -12, -22, -32
DIFFERENT AS SHOWN, OTHERWISE SAME AS FIG 1

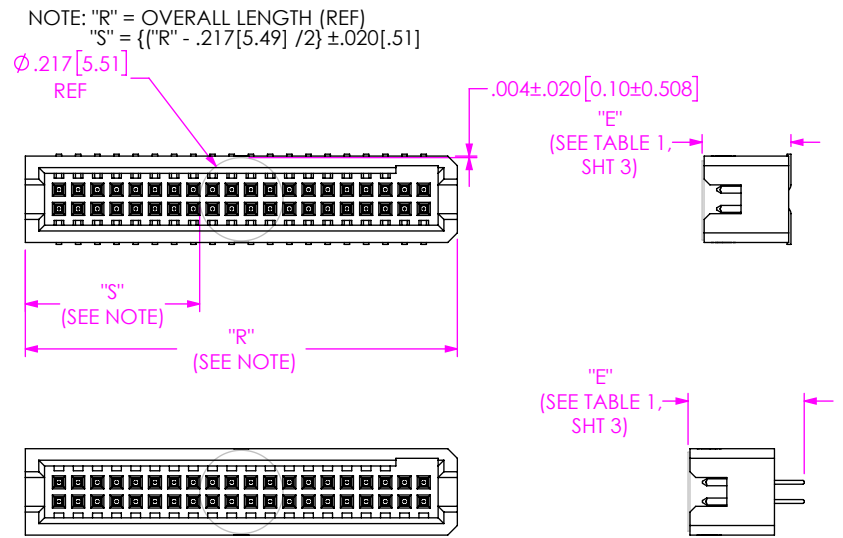

FIG 3
-K: POLYIMIDE FILM PAD

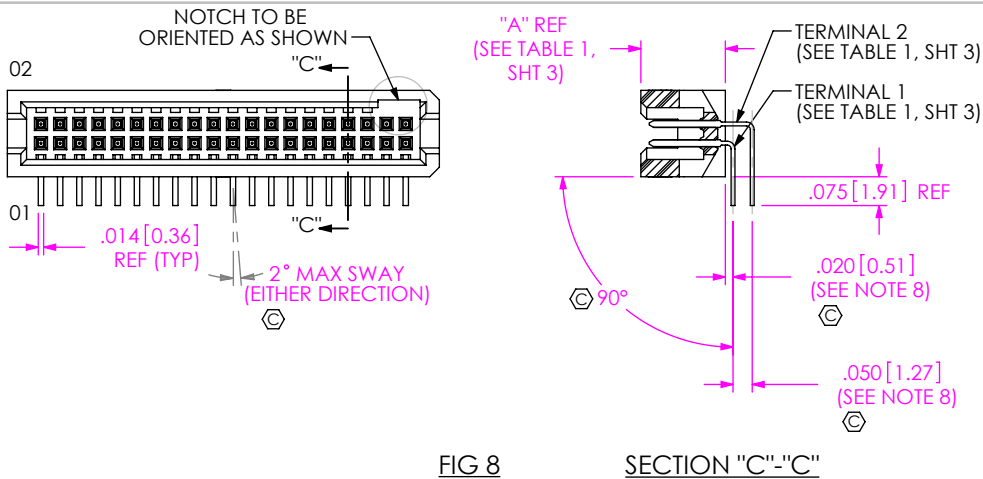
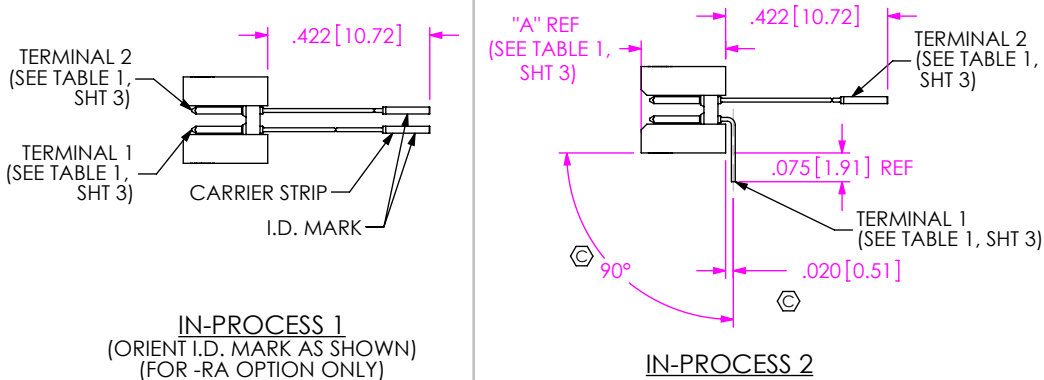

FIG 8
-RA OPTION
DIFFERENT AS SHOWN, OTHERWISE SAME AS FIG 1



F:\DWG\MISC\MKTG\TFC-1XX-XX-XX-D-XX-X-XX-MKT.SLDDRW

PROPRIETARY NOTE
THIS DOCUMENT CONTAINS CONFIDENTIAL AND PROPRIETARY INFORMATION AND ALL DESIGN, MANUFACTURING, REPRODUCTION, USE, PATENT RIGHTS AND SALES RIGHTS ARE EXPRESSLY RESERVED BY SAMTEC, INC. THIS DOCUMENT SHALL NOT BE DISCLOSED, IN WHOLE OR PART, TO ANY UNAUTHORIZED PERSON OR ENTITY NOR REPRODUCED, TRANSFERRED OR INCORPORATED IN ANY OTHER PROJECT IN ANY MANNER WITHOUT THE EXPRESS WRITTEN CONSENT OF SAMTEC, INC.

DO NOT SCALE DRAWING

SHEET SCALE: 2:1

samtec

520 PARK EAST BLVD, NEW ALBANY, IN 47150
PHONE: 812-944-6733 FAX: 812-948-5047
e-Mail info@SAMTEC.com code 55322

DESCRIPTION:
.050 X .050 TERMINAL STRIP

DWG. NO.
TFC-1XX-XX-XX-D-XX-X-XX

BY: BRATCHER 05/25/2001 SHEET 2 OF 4

TABLE 1									
LEAD STYLE	BODY	"A"	TERMINAL 1	TERMINAL 2	"C"	"D"	"E"	"F"	"J"
-01	TFM-XX-D-01-XX	.2200 [5.588]	T-1R16-01-XX-2	N/A	.428 [10.87]	.131 [3.33]	.303 [7.70]	.078 [1.98]	N/A
-11	TFM-XX-D-02-XX	.2900 [7.366]	T-1R20-03-XX	N/A	.645 [16.38]	.139 [3.53]	.375 [9.53]	.080 [2.03]	N/A
-21	TFM-XX-D-03-XX	.3600 [9.144]	T-1R20-04-XX	N/A	.645 [16.38]	.139 [3.53]	N/A	.080 [2.03]	N/A
-31	TFM-XX-D-04-XX	.4350 [11.049]	T-1R20-02-XX	N/A	.645 [16.38]	.139 [3.53]	.520 [13.21]	.080 [2.03]	N/A
-02	TFM-XX-D-01-XX	.2200 [5.588]	T-1R16-01-XX-2	N/A	.428 [10.87]	.131 [3.33]	.231 [5.87]	N/A	.226 [5.74]
-12	TFM-XX-D-02-XX	.2900 [7.366]	T-1R20-03-XX	N/A	.645 [16.38]	.139 [3.53]	.301 [7.65]	N/A	.296 [7.52]
-22	TFM-XX-D-03-XX	.3600 [9.144]	T-1R20-04-XX	N/A	.645 [16.38]	.139 [3.53]	.371 [9.42]	N/A	.366 [9.30]
-32	TFM-XX-D-04-XX	.4350 [11.049]	T-1R20-02-XX	N/A	.645 [16.38]	.139 [3.53]	.446 [11.33]	N/A	.441 [11.20]
-01-RA	TFM-XX-D-01-XX	.2200 [5.588]	T-1R16-02-XX	T-1R16-03-XX	N/A	.142 [3.61]	N/A	N/A	N/A

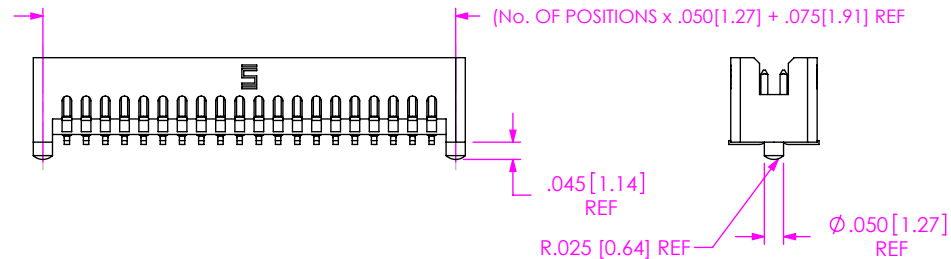
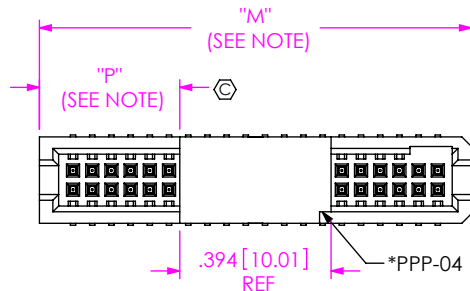
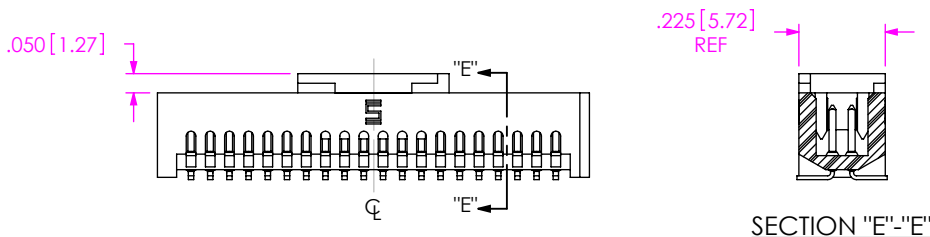

FIG 5
-A OPTION
DIFFERENT AS SHOWN, OTHERWISE SAME AS FIG 1



NOTE: "M" = (No. OF POS X .050 [1.27]) + .125 [3.18] (REF)
 "P" = {"M" - .394 [10.01]} / 2 ± .020 [51]

* NOTCH ON PAD TO BE ON SAME END AS THE NOTCH IN THE TFM BODY

FIG 7
-P OPTION
DIFFERENT AS SHOWN, OTHERWISE SAME AS FIG 1
(PAD TO BE POSITIONED ON CL AS SHOWN)

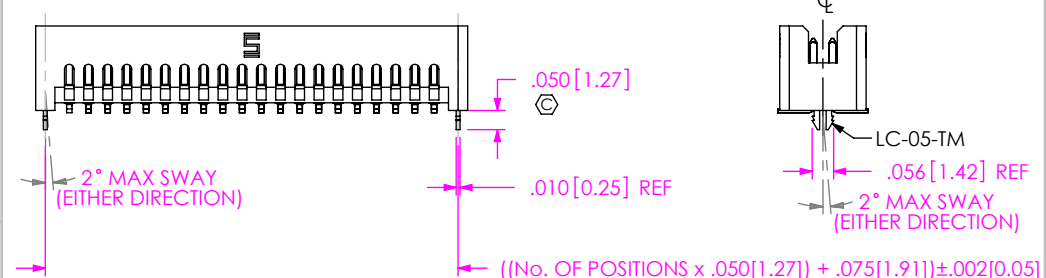

FIG 6
-LC OPTION
DIFFERENT AS SHOWN, OTHERWISE SAME AS FIG 1
(NOT AVAILABLE ON -RA)

F:\DWG\MISC\MKTG\TFC-1XX-XX-XX-D-XX-X-XX-MKT.SLDDRW

<p>PROPRIETARY NOTE</p> <p>THIS DOCUMENT CONTAINS CONFIDENTIAL AND PROPRIETARY INFORMATION AND ALL DESIGN, MANUFACTURING, REPRODUCTION, USE, PATENT RIGHTS AND SALES RIGHTS ARE EXPRESSLY RESERVED BY SAMTEC, INC. THIS DOCUMENT SHALL NOT BE DISCLOSED, IN WHOLE OR PART, TO ANY UNAUTHORIZED PERSON OR ENTITY NOR REPRODUCED, TRANSFERRED OR INCORPORATED IN ANY OTHER PROJECT IN ANY MANNER WITHOUT THE EXPRESS WRITTEN CONSENT OF SAMTEC, INC.</p> <p>DO NOT SCALE DRAWING</p> <p>SHEET SCALE: 2:1</p>	<p>520 PARK EAST BLVD, NEW ALBANY, IN 47150 PHONE: 812-944-6733 FAX: 812-948-5047 e-Mail: info@SAMTEC.com code 55322</p>
	<p>DESCRIPTION:</p> <p>.050 X .050 TERMINAL STRIP</p>
	<p>DWG. NO.</p> <p>TFC-1XX-XX-XX-D-XX-X-XX</p> <p>BY: BRATCHER 05/25/2001 SHEET 3 OF 4</p>

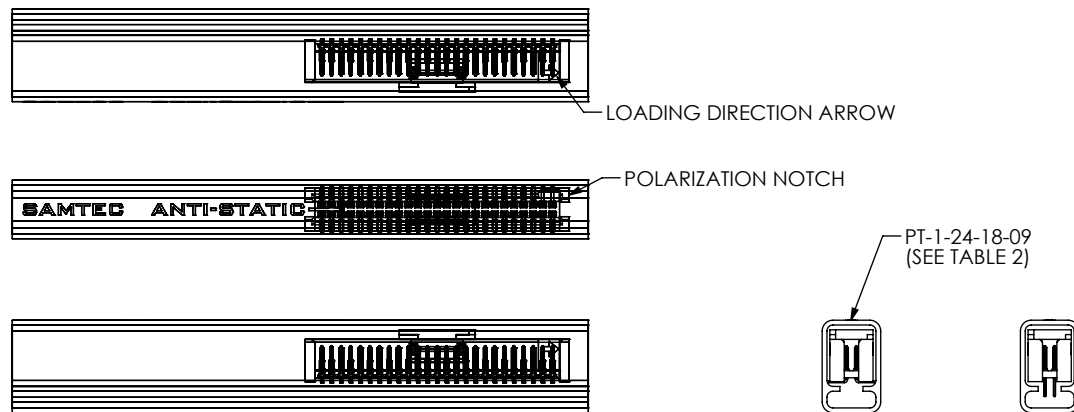

FIG 9
PT-1-24-XX-09

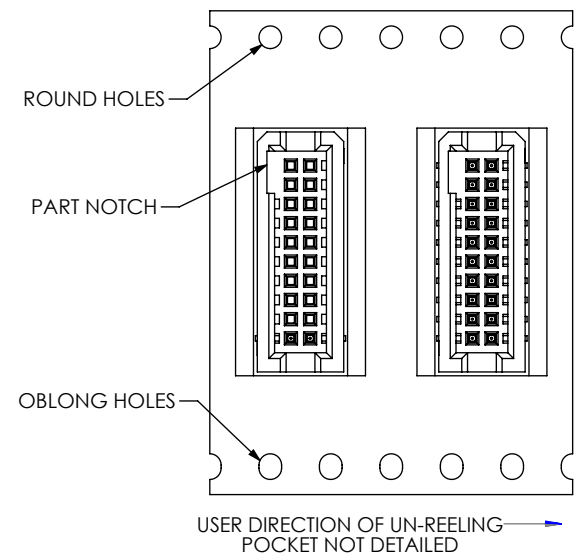

FIG 4
-TR: TAPE AND REEL
(SEE NOTE 13)

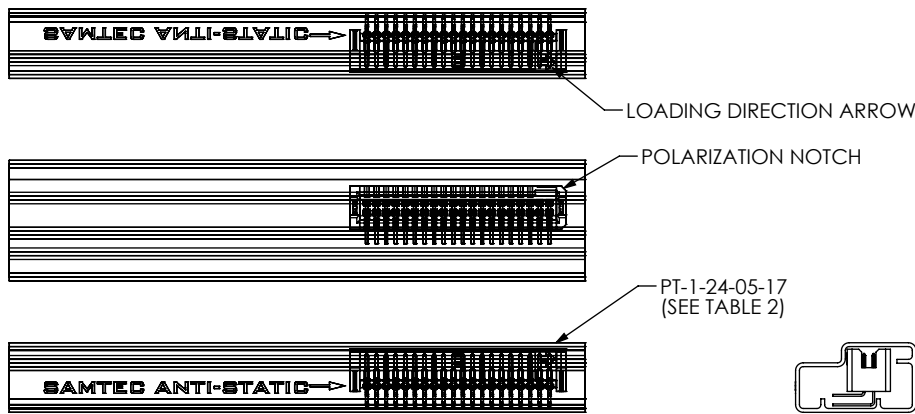

FIG 10
PT-1-24-05-17

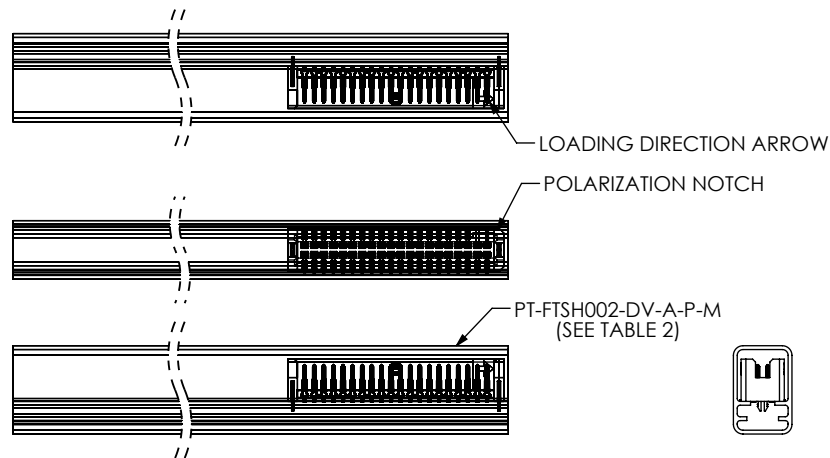

FIG 11
PT-FTSH002-DV-A-P-M

TABLE 2			
LEAD STYLE	OPTION	TUBE	PLUG
-01	-K, -LC-K, -LC-P, -A-P, -A-K, -P, -WT-P	PT-1-24-18-09	TP-09
	BLANK, -A, -LC, -WT	PT-FTSH002-DV-A-P-M	TP-03
-01-RA	ANY	PT-1-24-5-17	TP-07
	BLANK, -A, -A-K, -LC, -LC-K, -K	PT-1-24-18-09	TP-09
-11	-A-P, -LC-P, -P	PT-1-24-20-09	TP-07
	BLANK, -A-P, -LC-P, -P	PT-1-24-05-09	TP-07
-21	-A, -A-K, -LC, -LC-K, -K	PT-1-24-20-09	TP-07
	BLANK, -A, -LC	PT-1-24-05-09	TP-07
-31	-A-K, -LC-K, -K, -A-P, -LC-P, -P	PT-1-24-02-09	TP-07
	BLANK, -A, -A-K, -LC	PT-FTSH002-DV-A-P-M	TP-03
-02	-LC-K, -K, -A-P, -LC-P, -P	PT-1-24-18-09	TP-09
	ANY	PT-1-24-04-09	TP-07
-12	BLANK, -A, -A-K, -LC, -LC-K, -K	PT-1-24-04-09	TP-07
	-A-P, -LC-P, -P	PT-1-24-05-09	TP-07
-32	ANY	PT-1-24-02-09	TP-07

NOTE:
PARTS TO BE PACKAGED WITH THE LOADING DIRECTION ARROW
POINTED IN SAME DIRECTION AS THE ARROW ON TUBE.

F:\DWG\MISC\MKTG\TFC-1XX-XX-XX-D-XX-X-XX-MKT.SLDDRW

PROPRIETARY NOTE
THIS DOCUMENT CONTAINS CONFIDENTIAL AND PROPRIETARY INFORMATION AND ALL DESIGN, MANUFACTURING, REPRODUCTION, USE, PATENT RIGHTS AND SALES RIGHTS ARE EXPRESSLY RESERVED BY SAMTEC, INC. THIS DOCUMENT SHALL NOT BE DISCLOSED, IN WHOLE OR PART, TO ANY UNAUTHORIZED PERSON OR ENTITY NOR REPRODUCED, TRANSFERRED OR INCORPORATED IN ANY OTHER PROJECT IN ANY MANNER WITHOUT THE EXPRESS WRITTEN CONSENT OF SAMTEC, INC.

DO NOT SCALE DRAWING

SHEET SCALE: 2:1

samtec

520 PARK EAST BLVD. NEW ALBANY, IN 47150
PHONE: 812-944-6733 FAX: 812-948-5047
e-Mail info@SAMTEC.com code 55322

DESCRIPTION:
.050 X .050 TERMINAL STRIP

DWG. NO.
TFC-1XX-XX-XX-D-XX-X-XX

BY: BRATCHER 05/25/2001 SHEET 4 OF 4