

# Q4X Stainless Steel Analog Laser Sensor

## Instruction Manual

Original Instructions  
185624 Rev. H  
11 January 2023  
© Banner Engineering Corp. All rights reserved



185624

# Contents

<b>1 Product Description</b>	<b>3</b>
1.1 Models	3
1.2 Overview	3
1.3 Features	4
1.3.1 Display and Indicators	4
1.3.2 Buttons	4
1.4 Laser Description and Safety Information	5
<b>2 Installation</b>	<b>6</b>
2.1 Install the Safety Label	6
2.2 Sensor Orientation	6
2.3 Mount the Device	6
2.4 Wiring Diagram	7
2.5 Connecting to RSD1	7
<b>3 Sensor Programming</b>	<b>8</b>
3.1 Setup Mode	8
3.1.1 TEACH Menu	10
3.1.2 Base Measurement Rate	10
3.1.3 Averaging	10
3.1.4 Slope	12
3.1.5 Zero Reference Location	12
3.1.6 Shift the Zero Reference Location after a TEACH	12
3.1.7 Loss of Signal	13
3.1.8 Input Wire Function	14
3.1.9 Trigger	14
3.1.10 Display View	15
3.1.11 Exit Setup Mode	15
3.1.12 Reset to Factory Defaults	16
3.2 Manual Adjustments	16
3.2.1 Manual Adjustments in Two-Point TEACH Mode	16
3.2.2 Manual Adjustments in One-Point TEACH Mode	17
3.3 Remote Input	17
3.3.1 Select the TEACH Mode Using the Remote Input	18
3.3.2 Reset to Factory Defaults Using the Remote Input	18
3.4 Locking and Unlocking the Sensor Buttons	18
3.5 TEACH Procedures	19
3.5.1 Two-Point TEACH	19
3.5.2 One-Point TEACH	20
3.6 Sync Master/Slave	21
<b>4 Specifications</b>	<b>22</b>
4.1 FCC Part 15 Class A	24
4.2 Industry Canada	24
4.3 Dimensions	25
4.4 Performance Curves—Threaded Barrel Models	26
4.5 Performance Curves—Flush Mount Models	28
<b>5 Abbreviations</b>	<b>30</b>
<b>6 Troubleshooting</b>	<b>32</b>
<b>7 Accessories</b>	<b>33</b>
7.1 Cordsets	33
7.2 Brackets	35
7.3 Aperture Kits—Threaded Barrel Models	35
<b>8 Product Support and Maintenance</b>	<b>37</b>
8.1 Cleaning and Maintenance	37
8.2 Contact Us	37
8.3 Banner Engineering Corp. Limited Warranty	37

# 1 Product Description

Class 1 laser CMOS analog sensor with an analog output. Patent pending.

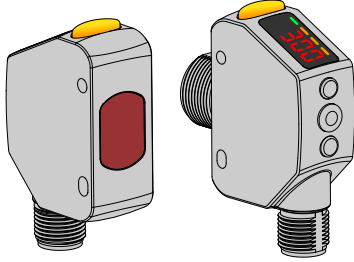

- Reliably detects submillimeter distance changes
- Continuous measurement of challenging targets from dark to reflective, out to 500 mm (threaded barrel models) or 310 mm (flush mount models), depending on model
- Resists mechanical impact, over tightening, and extreme vibration
- Simplified user experience with analog (V or mA) or distance (mm) readout from the angled, four-digit display
- Easy setup with responsive buttons
- Durable and robust construction resists mechanical impact, over tightening, and extreme vibration
- FDA grade stainless steel, rated to IP67, IP68, and IP69K, ECOLAB® certified chemically-resistant materials, and laser marked sensor information withstands aggressive cleaning procedures
- Superior ambient light resistance

For illustration purposes, the threaded barrel model Q4X images are used throughout this document.



## WARNING:

- **Do not use this device for personnel protection**
- Using this device for personnel protection could result in serious injury or death.
- This device does not include the self-checking redundant circuitry necessary to allow its use in personnel safety applications. A device failure or malfunction can cause either an energized (on) or de-energized (off) output condition.

## 1.1 Models

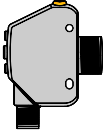
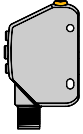
Model	Sensing Range	Output	Connection <sup>1</sup>	
	Q4XTULAF600-Q8	25 mm to 600 mm (0.98 in to 23.62 in)	Analog voltage (0 to 10 V)	
	Q4XTILAF600-Q8		Analog current (4 to 20 mA)	
	Q4XTULAF500-Q8	25 mm to 500 mm (0.98 in to 19.68 in)	Analog voltage (0 to 10 V)	Integral 5-pin M12 male quick-disconnect connector
	Q4XTILAF500-Q8		Analog current (4 to 20 mA)	
	Q4XTULAF300-Q8	25 mm to 300 mm (0.98 in to 11.81 in)	Analog voltage (0 to 10 V)	
	Q4XTILAF300-Q8		Analog current (4 to 20 mA)	
	Q4XTULAF100-Q8	25 mm to 100 mm (0.98 in to 3.94 in)	Analog voltage (0 to 10 V)	
	Q4XTILAF100-Q8		Analog current (4 to 20 mA)	
	Q4XTULAF610-Q8	35 mm to 610 mm (1.38 in to 24.02 in)	Analog voltage (0 to 10 V)	
	Q4XTILAF610-Q8		Analog current (4 to 20 mA)	
	Q4XFULAF310-Q8	35 mm to 310 mm (1.38 in to 12.20 in)	Analog voltage (0 to 10 V)	
	Q4XFILAF310-Q8		Analog current (4 to 20 mA)	
	Q4XFULAF110-Q8	35 mm to 110 mm (1.38 in to 4.33 in)	Analog voltage (0 to 10 V)	
	Q4XFILAF110-Q8		Analog current (4 to 20 mA)	

## 1.2 Overview

The Q4X Analog Sensor is a Class 1 laser CMOS measuring sensor that uses a 0 to 10 V (4 to 20 mA) output to represent the distance measured.

When the sensor is in Run mode, the display shows the current measurement reading or corresponding analog output value. The size and location of the analog output window can be manually adjusted or the selected TEACH method can be performed.

<sup>1</sup> QD models require a mating cordset.

When the sensor is in Setup mode, all standard operating parameters, including TEACH mode, analog slope, response time, and more can be adjusted, or a factory reset can be performed.

## 1.3 Features

Figure 1. Sensor Features

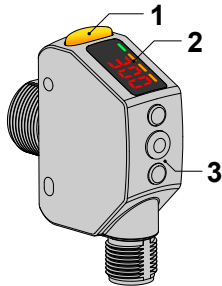

1. Output Indicator (Amber)
2. Display
3. Buttons

### 1.3.1 Display and Indicators

The display is a 4-digit, 7-segment LED. The main screen is the Run Mode screen, which shows the current distance to the target in millimeters.

Figure 2. Display in Run Mode

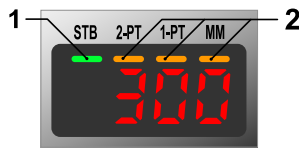

1. Stability Indicator (STB = Green)
2. Active TEACH Indicators
  - 2-PT = Two-Point TEACH (Amber)
  - 1-PT = One-Point TEACH (Amber)
3. Display Value Indicator (MM = Amber)

#### Output Indicator

- On—Displayed distance is within the taught analog output window
- Off—Displayed distance is outside of the taught analog output window

#### Stability Indicator (STB)

- On—Stable signal within the specified sensing range
- Flashing—Marginal signal, the target is outside of the limits of the specified sensing range, or a multiple peak condition exists
- Off—No target detected within the specified sensing range

#### Active TEACH Indicators (2PT and 1PT)

- 2-PT on—Two-point TEACH mode selected (default)
- 1-PT on—One-point TEACH mode selected

#### Display Value Indicator (MM)

- On—Display shows the distance in millimeters (default)
- Off—Display shows the analog output value

### 1.3.2 Buttons

Use the sensor buttons **(SELECT)(TEACH)**, **(+)(DISP)**, and **(-)(MODE)** to program the sensor.

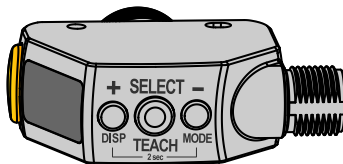

**(SELECT)(TEACH)**

- Press and hold for longer than 2 seconds to start the currently selected TEACH mode (the default is two-point TEACH)
- Press to select menu items in Setup mode

**(-)(MODE)**

- Press to change the distance setting for the 0 V (4 mA ) point; press and hold to decrease numeric values
- Press and hold for longer than 2 seconds to enter Setup mode
- Press to navigate the sensor menu in Setup mode

**(+)(DISP)**

- Press to change the distance setting for the 10 V (20 mA) point; press and hold to increase numeric values
- Press and hold for longer than 2 seconds to toggle the display value between the distance and the analog output
- Press to navigate the sensor menu in Setup mode



**Note:** When navigating the menu, the menu items loop.

## 1.4 Laser Description and Safety Information

---

**CAUTION:**

- **Return defective units to the manufacturer.**
- Use of controls or adjustments or performance of procedures other than those specified herein may result in hazardous radiation exposure.
- Do not attempt to disassemble this sensor for repair. A defective unit must be returned to the manufacturer.

### ≤ 510 mm Models - IEC 60825-1:2007 Class 1 Laser

Class 1 lasers are lasers that are safe under reasonably foreseeable conditions of operation, including the use of optical instruments for intrabeam viewing.



**Laser wavelength:** 655 nm

**Output:** < 0.20 mW

**Pulse Duration:** 7 μs to 2 ms

### > 510 mm Models - IEC 60825-1:2014 Class 1 Laser

Class 1 lasers are lasers that are safe under reasonably foreseeable conditions of operation, including the use of optical instruments for intrabeam viewing.

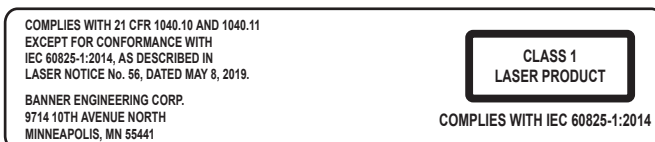

**Laser wavelength:** 655 nm

**Output:** < 0.39 mW

**Pulse Duration:** 7 μs to 2 ms

## 2 Installation

### 2.1 Install the Safety Label

The safety label must be installed on Q4X sensors that are used in the United States.



**Note:** Position the label on the cable in a location that has minimal chemical exposure.

1. Remove the protective cover from the adhesive on the label.
2. Wrap the label around the Q4X cable, as shown.
3. Press the two halves of the label together.

Figure 3. Safety Label Installation

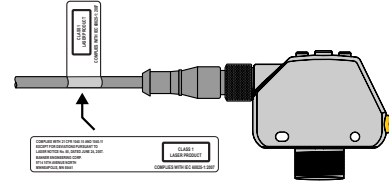

### 2.2 Sensor Orientation

Optimize detection reliability and performance with correct sensor-to-target orientation. To ensure reliable detection, orient the sensor as shown in relation to the target to be detected.

Figure 4. Optimal Orientation of Target to Sensor

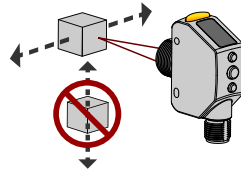

See the following figures for examples of correct and incorrect sensor-to-target orientation as certain placements may pose problems for sensing some targets.

Figure 5. Orientation by a wall

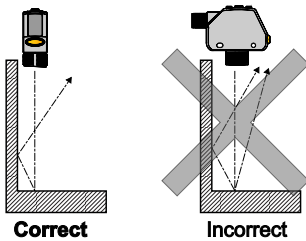

Figure 6. Orientation for a turning object

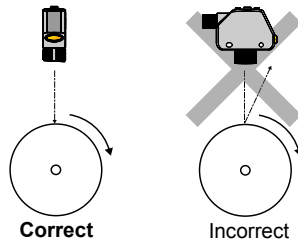

Figure 7. Orientation for a height difference

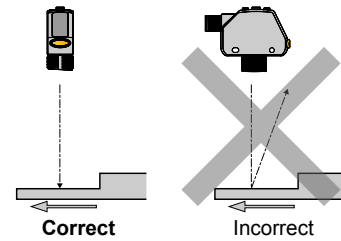

Figure 8. Orientation for a color or luster difference

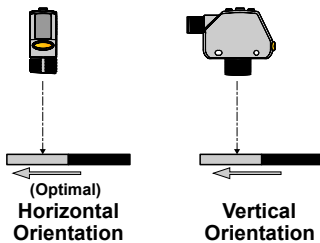
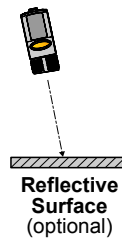

Figure 9. Orientation for highly reflective target <sup>2</sup>



### 2.3 Mount the Device

1. If a bracket is needed, mount the device onto the bracket.

<sup>2</sup> Applying tilt to sensor may improve performance on reflective targets. The direction and magnitude of the tilt depends on the application, but a 15° tilt is often sufficient.

2. Mount the device (or the device and the bracket) to the machine or equipment at the desired location. Do not tighten the mounting screws at this time.
3. Check the device alignment.
4. Tighten the mounting screws to secure the device (or the device and the bracket) in the aligned position.

## 2.4 Wiring Diagram

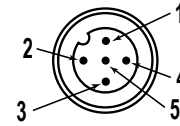
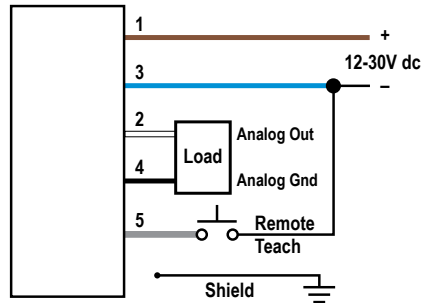

**Key**

- 1 = Brown
- 2 = White
- 3 = Blue
- 4 = Black
- 5 = Gray



**Note:** Open lead wires must be connected to a terminal block.



**Note:** The input wire function is user-selectable. The default for the input wire function is off (disabled).



**Note:** Shielded cordsets are recommended for all models with quick disconnect fittings. It is recommended that the shield wire be connected to -V DC (the blue wire).

## 2.5 Connecting to RSD1

The following diagram depicts the connection of the Q4XTULAF600, Q4XTILAF600, Q4XTULAF610, or Q4XTILAF610 to the optional RSD1 accessory.

Figure 10. Q4X to RSD1

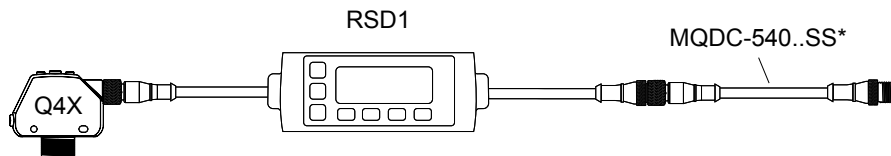

\*Optional Extension Cordset: MQDEC3-5..SS

## 3 Sensor Programming

Program the sensor using the buttons on the sensor or the remote input (limited programming options).

In addition to programming the sensor, use the remote input to disable the buttons for security, preventing unauthorized or accidental programming changes. See for more information.

### 3.1 Setup Mode

---

1. Access Setup mode and the sensor menu from Run mode by pressing and holding **MODE** for longer than 2 seconds.
2. Use **+** and **-** to navigate through the menu.
3. Press **SELECT** to select a menu option and access the submenus.
4. Use **+** and **-** to navigate through the submenus.
5. Select a submenu option.
  - Press **SELECT** to select a submenu option and return to the top menu.
  - Press and hold **SELECT** for longer than 2 seconds to select a submenu option and return immediately to Run mode.

To exit Setup mode and return to Run mode, navigate to **End** and press **SELECT**.



Figure 11. Sensor Menu Map

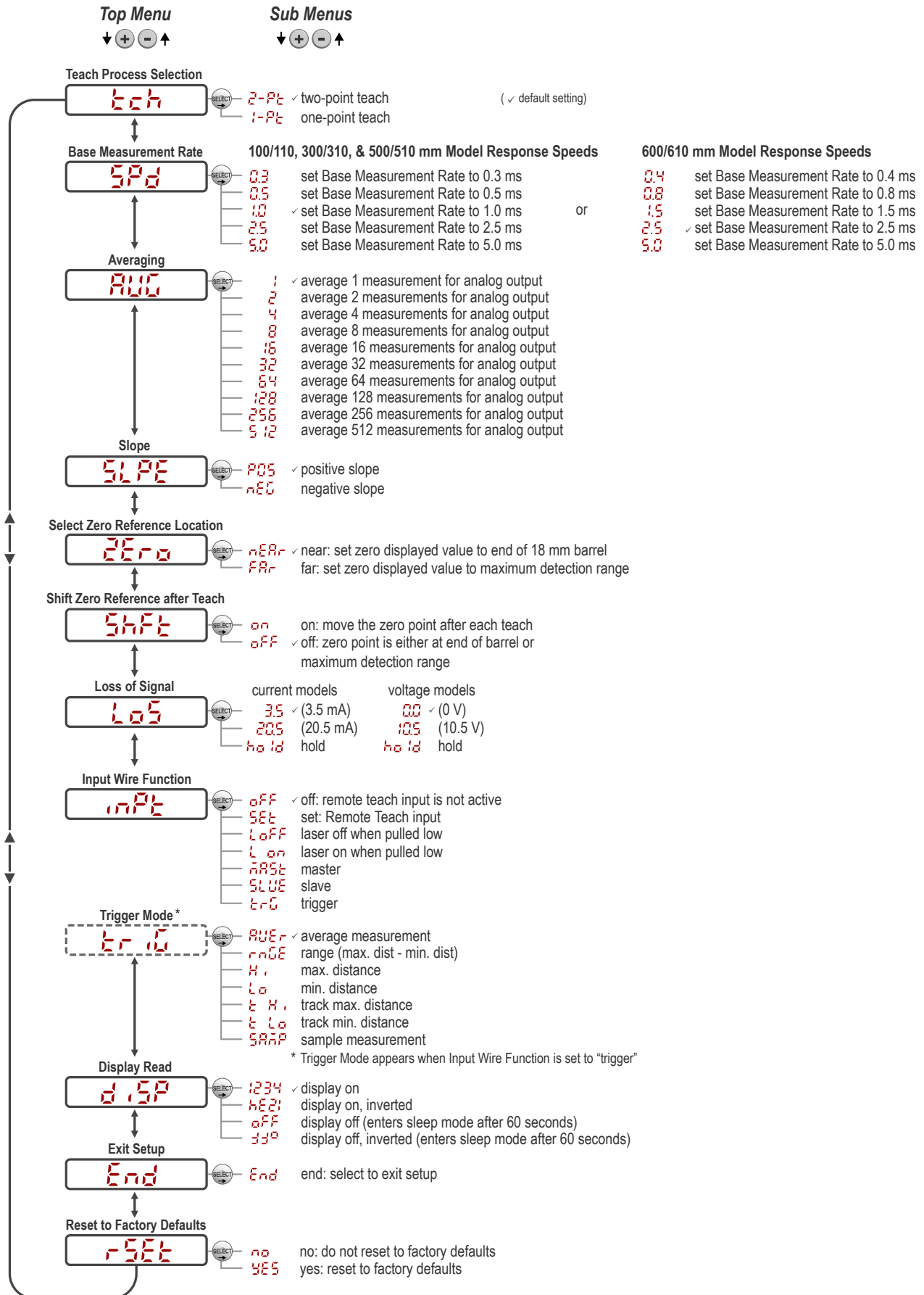

### 3.1.1 TEACH Menu TECH

Use this menu to select the TEACH mode. The default is two-point TEACH.

- 2-PT —Two-point
- 1-PT —One-point TEACH

After the TEACH mode is selected, from Run mode, press and hold **TEACH** for longer than 2 seconds to start the TEACH mode and program the sensor. See [TEACH Procedures](#) on page 19 for additional information and remote input TEACH instructions.

### 3.1.2 Base Measurement Rate SPD

Use this menu to select the base measurement rate. The total response speed depends upon the measurement rate setting and the averaging setting. See [Averaging](#) on page 10 for more information.

- 03 —0.3 ms
- 05 —0.5 ms
- 10 —1.0 ms
- 25 —2.5 ms
- 50 —5.0 ms

Table 1: Tradeoffs—Threaded Barrel Models

Base Measurement Rate (ms)	Base Measurement Rate in Sync Mode (ms)	Ambient Light Rejection	Excess Gain—90% white card			
			at 25 mm	at 100 mm	at 300 mm	at 600 mm
0.4	0.8	Disabled	560	220	50	12
0.8	1.6	Enabled	560	220	50	12
1.5	3.0	Enabled	2000 (720)	800 (300)	160 (60)	40 (14)
2.5	5.0	Enabled	4000 (2000)	1600 (800)	320 (160)	80 (40)
5.0	10.0	Enabled	8000 (4000)	3200 (1600)	640 (320)	160 (80)

Table 2: Tradeoffs—Flush Mount Models

Base Measurement Rate (ms)	Base Measurement Rate in Sync Mode (ms)	Ambient Light Rejection	Excess Gain—90% white card			
			at 35 mm	at 110 mm	at 310 mm	at 610 mm
0.4	0.8	Disabled	560	220	50	12
0.8	1.6	Enabled	560	220	50	12
1.5	3.0	Enabled	2000 (720)	800 (300)	160 (60)	40 (14)
2.5	5.0	Enabled	4000 (2000)	1600 (800)	320 (160)	80 (40)
5.0	10.0	Enabled	8000 (4000)	3200 (1600)	640 (320)	160 (80)

### 3.1.3 Averaging AUC

Use this menu to set the number of measurements that are averaged together for the analog output. Increasing the averaging improves repeatability, but increases the total response speed. The default is 1. The filter can be set to 1, 2, 4, 8, 16, 32, 64, 128, 256, or 512. Use the table to determine the total response speed.



**Note:** The Q4X uses a dynamic measurement rate, so these response times are worst-case.

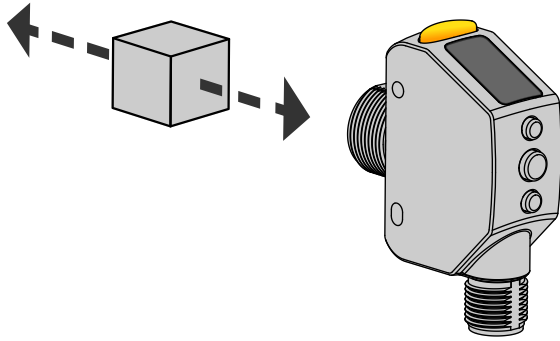

Table 3: Response Speed for 100/110, 300/310, and 500/510 models

Base Measurement Rate	Filter Setting									
	1	2	4	8	16	32	64	128	256	512
0.3 ms	0.5 ms	0.75 ms	1.5 ms	4 ms	8 ms	15 ms	30 ms	60 ms	120 ms	240 ms
0.5 ms	0.5 ms	1 ms	2 ms	5 ms	10 ms	25 ms	50 ms	100 ms	200 ms	350 ms
1 ms	1 ms	3 ms	5 ms	10 ms	20 ms	40 ms	75 ms	150 ms	300 ms	600 ms
2.5 ms	2.5 ms	5 ms	10 ms	25 ms	45 ms	80 ms	160 ms	320 ms	640 ms	1280 ms
5 ms	5 ms	10 ms	20 ms	40 ms	80 ms	160 ms	320 ms	640 ms	1280 ms	2560 ms

Table 4: Response Speed for 600/610 models

Base Measurement Rate	Filter Setting									
	1	2	4	8	16	32	64	128	256	512
0.4 ms	0.5 ms	1.2 ms	2.5 ms	7 ms	13 ms	25 ms	50 ms	100 ms	200 ms	400 ms
0.8 ms	0.8 ms	1.6 ms	3.5 ms	8 ms	16 ms	40 ms	80 ms	160 ms	320 ms	560 ms
1.5 ms	1.5 ms	4.5 ms	8 ms	15 ms	30 ms	60 ms	115 ms	225 ms	450 ms	900 ms
2.5 ms	2.5 ms	5 ms	10 ms	20 ms	40 ms	80 ms	160 ms	320 ms	640 ms	1300 ms
5 ms	5 ms	10 ms	20 ms	40 ms	80 ms	160 ms	320 ms	640 ms	1300 ms	2500 ms

When lateral entry needs to be considered, the lateral entry response is added to calculate the total response time.

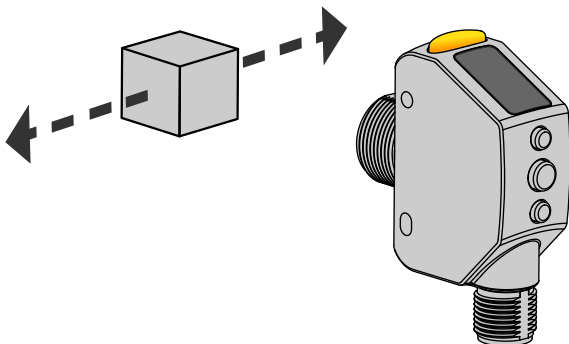

Table 5: Lateral Entry Response

Base Measurement Rate	Lateral Entry Response
0.4 ms	2 ms
0.8 ms	5 ms
1.5 ms	15 ms
2.5 ms	25 ms
5 ms	50 ms

### 3.1.4 Slope **SLPE**

Use this menu to set the slope as positive or negative.

This swaps the 0 V and 10 V (4 and 20 mA) values. The default is positive. The slope is defined relative to the zero reference, so if the zero setting is changed from near to far, a slope will be considered positive if the analog output increases as the target becomes closer to the face of the sensor.

- **POS** —the slope is positive
- **NEG** —the slope is negative

Figure 12. Slope—Voltage Sourcing Models

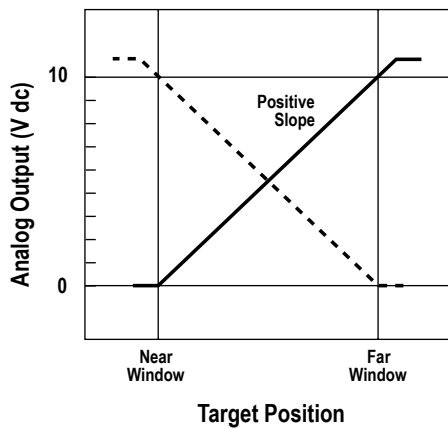
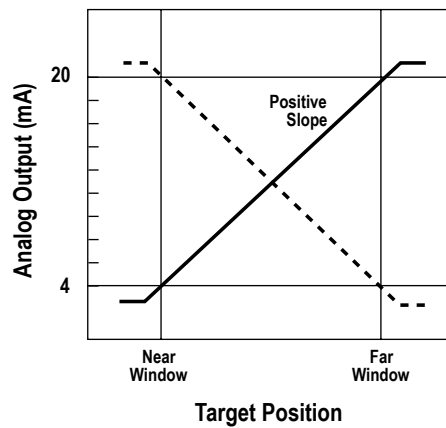

Figure 13. Slope—Current-Sourcing Models



The analog voltage output tracks slightly beyond the upper window limit (up to 10.2 V)

The analog current output tracks slightly beyond each window limit (from 3.8 mA to 20.2 mA)

### 3.1.5 Zero Reference Location **ZERO**

Use this menu to select the zero reference location. Changing the zero reference location only affects the readout on the display and does not affect the output.

The default is **NEAR**, 0 = the front of the sensor.

**NEAR** —0 is the front of the sensor and the measurement increases further from the sensor.

**FAR** —0 is the maximum range and the measurement increases closer to the sensor.

### 3.1.6 Shift the Zero Reference Location after a TEACH **SHIFT**

Use this menu to select whether the sensor shifts the zero reference location based on the last TEACH process. The default is **OFF**, 0 = the front of the sensor or the maximum range.

- **ON** —Shift the zero reference location to one of the taught positions with each TEACH
- **OFF** —0 = the front of the sensor or the maximum range, depending on the **ZERO** setting

This figure illustrates three examples of how changes to the zero and shift settings affect what distance readout is shown on the display when in 2-pt TEACH mode. Changes to the zero setting affect the direction in which the distance increases. Turning the shift setting on sets the taught location as the reference point for any distance measurement. For two-point TEACH, this is the 0 V (4 mA) point. For one-point TEACH, this is the 5 V (12 mA) point.

Figure 14. Example Zero and Shift settings

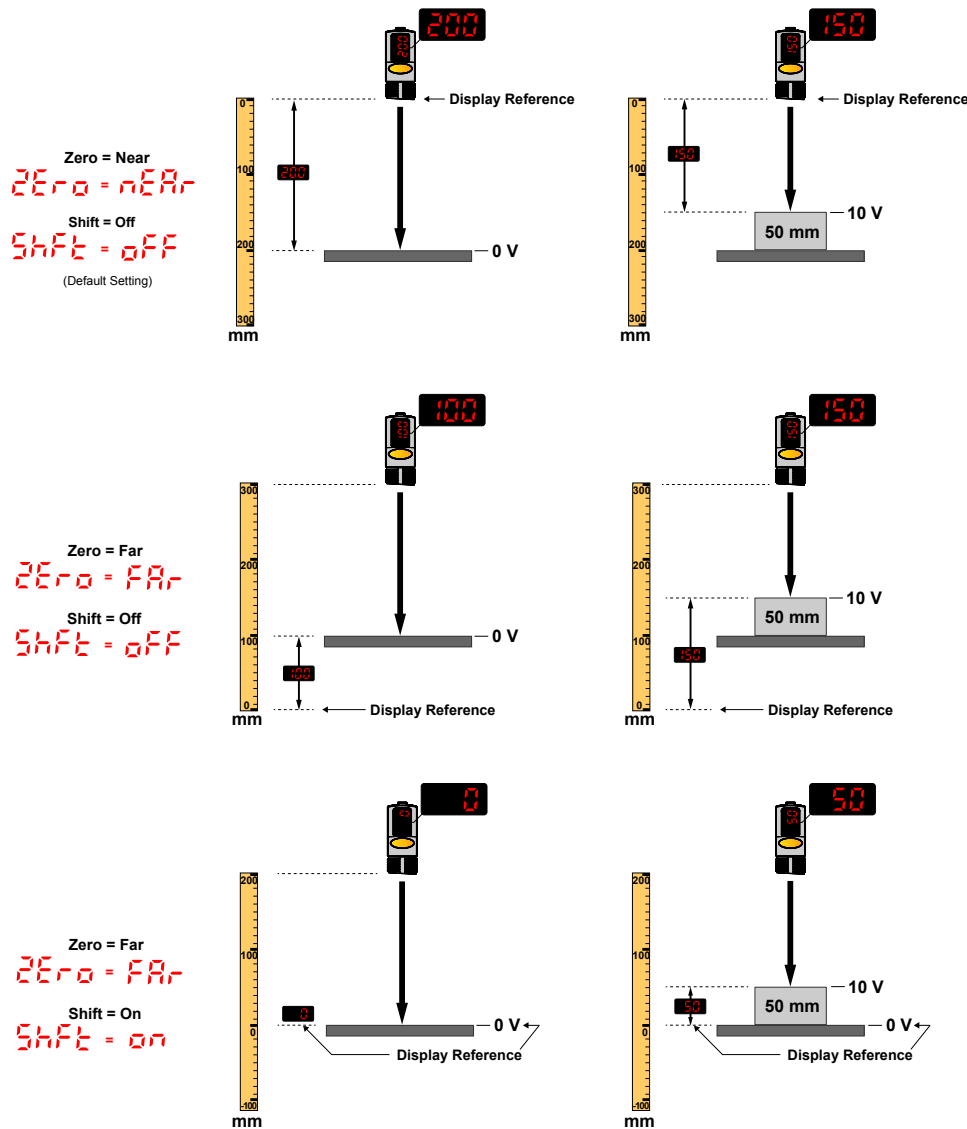

### 3.1.7 Loss of Signal LOS

Use this menu to select the Analog Output value used by the sensor during a loss of signal. When a signal is restored, measurement resumes. The default is 0 V (4 mA).

Table 6: Analog output value during a loss of signal

Option	Description
0 V (4 mA)—default	The Analog Output switches to this value 2 seconds after a loss of signal. When advanced measurements are enabled, the Analog Output is updated to this value immediately upon the release of the trigger input.
10.5 V (20.5 mA)	The Analog Output switches to this value 2 seconds after a loss of signal. When advanced measurements are enabled, the Analog Output is updated to this value immediately upon the release of the trigger input.

Option	Description
Hold	The Analog Output holds the last value indefinitely during a loss of signal. When advanced measurements are enabled, the last value is held across the triggered measurement periods.

The Range advanced measurement behavior is affected by the Loss of Signal option. For additional information on advanced measurements, see [Trigger](#) on page 14. The Range advanced measurement tracks a maximum and a minimum during the measurement period, and calculates the range as follows:

**Range = maximum distance – minimum distance**

If the maximum and/or minimum measurements are outside of the taught range values, the Loss of Signal option determines how the range is calculated.

Table 7: Sensor behavior in range mode

Option	Description
0 V (4 mA)	If the maximum or minimum measurement is outside of the taught range values, the sensor outputs 0 V (4 mA) to indicate an out of range measurement.
10.5 V (20.5 mA)	If the maximum or minimum measurement is outside of the taught range values, the sensor outputs 10.5 V (20.5 mA) to indicate an out of range measurement.
Hold	The sensor limits the maximum and minimum measurements so that they cannot exceed the taught range values.

### 3.1.8 Input Wire Function inPt

Use this menu to select the input wire function. The default is off, ignore all remote input pulses.

- off —Ignore all remote input pulses
- SEt —Remote TEACH input
- LoFF —Laser off when pulled low
- LoN —Laser on when pulled low
- mASt —Master sync line output for two-sensor cross-talk avoidance
- SLAVE —Slave sync line input for two-sensor cross-talk avoidance
- trG —Trigger mode for advanced measurements (see )

To configure sensors for master-slave operation, see .

### 3.1.9 Trigger trG

The Trigger option sets the advanced measurement that is calculated when a trigger event is detected on the remote input. The analog output updates with the new advanced measurement on each trigger event. To use these Trigger options, the sensor Input Type option must be set to trG.

Table 8: Trigger submenus

Trigger Submenus	Description
Average <span style="color: red;">AVEr</span>	The averaged distance since the last trigger event. (default)
Range <span style="color: red;">rNGE</span>	The difference between the maximum and minimum distance since the last trigger event. For additional information on the Range measurement behavior when the maximum or minimum distance is outside of the taught values, see <a href="#">Loss of Signal</a> on page 13.
Maximum <span style="color: red;">Hi</span>	The maximum distance since the last trigger event.
Minimum <span style="color: red;">Lo</span>	The minimum distance since the last trigger event.
TrackMax <span style="color: red;">tHi</span>	The maximum distance since the last trigger event. The Analog Output tracks new maximum values during the measurement period.

Trigger Submenus	Description
TrackMin <b>t Lo</b>	The minimum distance since the last trigger event. The Analog Output tracks new minimum values during the measurement period.
Sample <b>SAMP</b>	The current distance at the time of the trigger event. The Analog Output tracks the sample values during the measuring period.

Figure 15. Sample

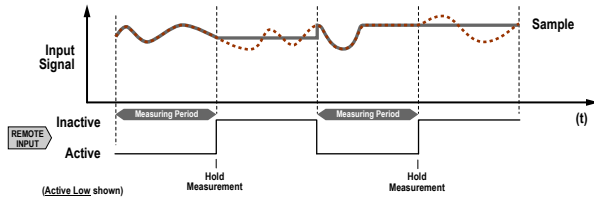

Figure 16. Average

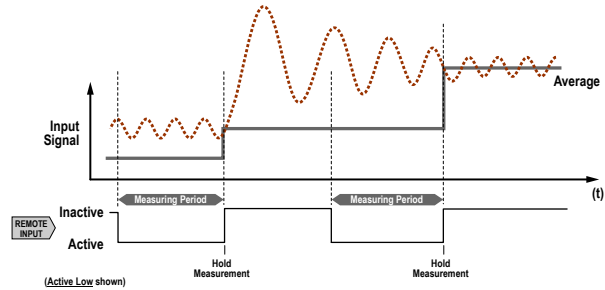

Figure 17. Maximum and Minimum

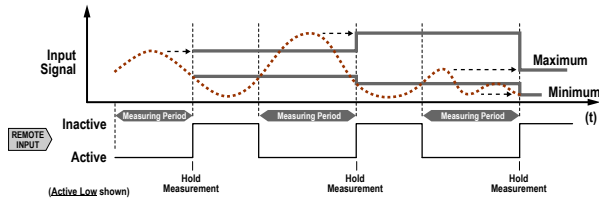

Figure 18. Range

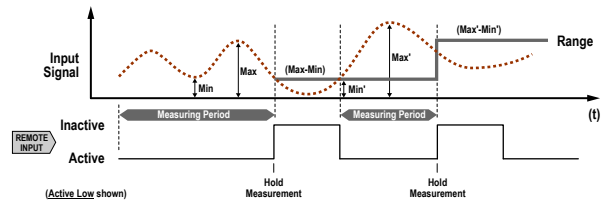
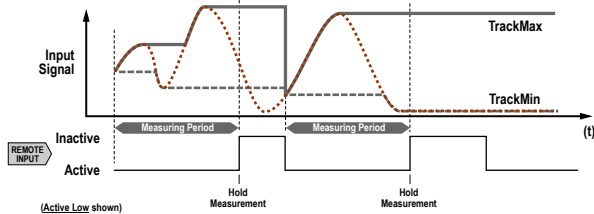

Figure 19. Track Maximum and Track Minimum



### 3.1.10 Display View **d SP**

Use this menu to select the display view.

When the sensor is in sleep mode, the display wakes with the first button press.

**1234** —Normal (default setting)

**4E21** —Inverted (rotated 180°)

**off** —Normal and the display enters sleep mode after 60 seconds

**33°** —Inverted (rotated 180°) and the display enters sleep mode after 60 seconds

### 3.1.11 Exit Setup Mode **End**

Use this menu to end Setup mode.

Navigate to **End** and press **SELECT** to exit Setup mode and return to Run mode.

### 3.1.12 Reset to Factory Defaults *RESET*

Use this menu to restore the sensor to the factory default settings.



*NO* —Select to return to the sensor menu without restoring the defaults.

*YES* —Select to apply the factory defaults and return to Run mode.

### Factory Default Settings

Setting	Factory Default
Averaging ( <i>Avg</i> )	<i>1</i>
Base Measurement Rate ( <i>SPd</i> )	<i>1</i> —1 ms
Display View ( <i>d.SP</i> )	<i>1234</i> —Normal, no sleep mode
Input Wire Function ( <i>inPt</i> )	<i>off</i> —Ignore all remote input pulses If the sensor was reset using the remote input, the sensor remains in <i>SET</i> mode to allow use of the remote input.
Loss of Signal ( <i>LOS</i> )	<i>00</i> —0 V (4 mA)
Shift the Zero Reference Location after a TEACH ( <i>SHft</i> )	<i>off</i> —0 = the front of the sensor
Slope ( <i>SLPE</i> )	<i>POS</i> —positive
TEACH Mode ( <i>teCh</i> )	<i>2-pt</i> —Two-point TEACH
Zero Reference Location ( <i>ZEro</i> )	<i>nEAR</i> —Measurement increases further from sensor

## 3.2 Manual Adjustments

Manually adjust the distance set for the 0 V (4 mA) and 10 V (20 mA) values using the  and  buttons. The available adjustments vary depending on the TEACH mode selected.



### 3.2.1 Manual Adjustments in Two-Point TEACH Mode

#### Adjust the 10 V (20 mA) Point

- From Run mode, press  to view and adjust the distance associated with the 10 V (20 mA) point. *10 V* displays briefly, then the value slowly flashes indicating it can be changed.



**Note:** If no changes are made within 8 seconds, the current distance value flashes quickly and the sensor returns to Run mode.

- Press  to move the value up or  to move the value down.



**Note:** If no additional changes are made within 4 seconds, the current distance value flashes quickly and the sensor returns to Run mode.

- Press **Select** to confirm the new distance value. The new distance flashes rapidly, the new setting is accepted, and the sensor returns to Run mode.

#### Adjust the 0 V (4 mA) Point

- Press  to view and adjust the distance associated with the 0 V (4 mA) point. *0 V* flashes briefly, then the value flashes.





**Note:** If no changes are made within 8 seconds, the current distance value flashes quickly and the sensor returns to Run mode.

2. Press to move the value up or to move the value down.



**Note:** If no additional changes are made within 4 seconds, the current distance value flashes quickly and the sensor returns to Run mode.

3. Press **Select** to confirm the new distance value. The new distance value flashes rapidly, the new setting is accepted, and the sensor returns to Run mode.

## 3.2.2 Manual Adjustments in One-Point TEACH Mode

### Adjust the 5 V (12 mA) Midpoint

1. From Run mode, press to view and adjust the distance setting associated with the 5 V (12 mA) midpoint (the midpoint of the analog span). **5 U** displays briefly, then the value slowly flashes indicating it can be changed.



**Note:** If no changes are made within 8 seconds, the current distance value flashes quickly and the sensor returns to Run mode.

2. Press to move the midpoint up or to move the midpoint down.



**Note:** If no additional changes are made within 4 seconds, the current distance value flashes quickly and the sensor returns to Run mode.

3. Press **Select** to confirm the new midpoint. The new midpoint value flashes rapidly, the new setting is accepted, and the sensor returns to Run mode.

### Adjust the Analog Window Size

1. Press to view and adjust the SPAN (the analog window size). **SPAN** flashes briefly, then the value flashes.
2. Press to increase the size of the analog window or to decrease the size of the analog window.
3. Press **Select** to confirm the window size. The new window size flashes rapidly, the new setting is accepted, and the sensor returns to Run mode.

## 3.3 Remote Input

Use the remote input to program the sensor remotely.

The remote input provides limited programming options and is Active low.

For Active low, connect the gray input wire to ground (0 V DC), with a remote switch connected between the wire and ground.

Pulse the remote input according to the diagram and the instructions provided in this manual.

The length of the individual programming pulses is equal to the value **T: 0.04 seconds ≤ T ≤ 0.8 seconds**.

Exit remote programming modes by setting the remote input low for longer than 2 seconds.

Figure 20. Remote Input Map

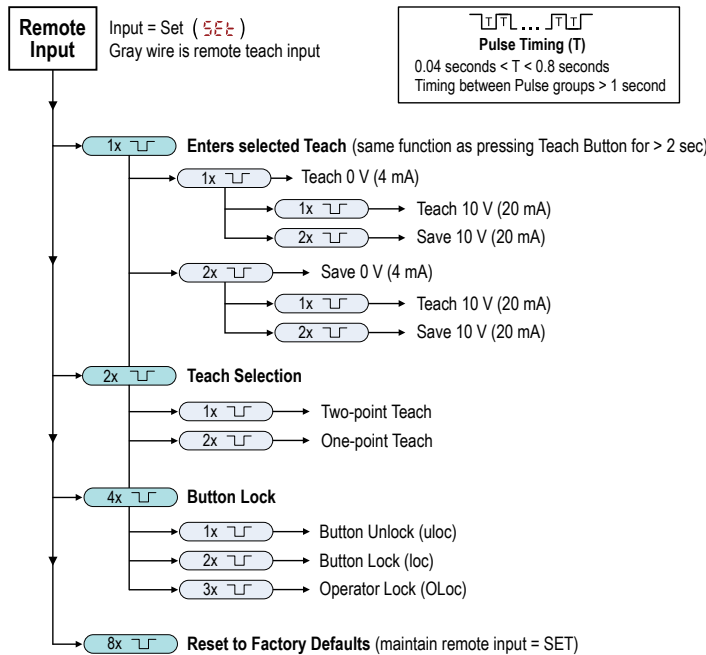



### 3.3.1 Select the TEACH Mode Using the Remote Input

Follow the instructions below to choose a specific TEACH Mode using Remote Input.

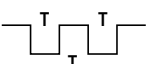
1. Access the TEACH selection.

Action	Result
Double-pulse the remote input. 	<b>teach</b> displays.

2. Select the desired TEACH mode.

Action		Result
Pulses	TEACH Mode	
1 	Two-point TEACH	The selected TEACH method displays for a few seconds and the sensor returns to Run mode.
2 	One-point TEACH	

### 3.3.2 Reset to Factory Defaults Using the Remote Input

Follow the instructions below to reset the Q4X to factory defaults using Remote Input.

Eight-pulse the remote input to apply the factory defaults and return to Run mode.



**Note:** The input wire function remains at remote teach input ( **SET** ).

## 3.4 Locking and Unlocking the Sensor Buttons

Use the lock and unlock feature to prevent unauthorized or accidental programming changes.

Three settings are available:

- **uLoc** —The sensor is unlocked and all settings can be modified (default).
- **Loc** — The sensor is locked and no changes can be made.
- **OLoc** —The value associated with 0 V (4 mA) and 10 V (20 mA ) can be changed by teaching or manual adjustment, but no sensor settings can be changed through the menu.

When in **Loc** mode, **Loc** displays when the **(SELECT)(TEACH)** button is pressed. The analog point displays when **(+)(DISP)** or **(-)(MODE)** are pressed, but **Loc** displays if the buttons are pressed and held.

When in **OLoc** mode, **Loc** displays when **(+)(DISP)** or **(-)(MODE)** are pressed and held. To access the manual adjust options, briefly press and release **(+)(DISP)** or **(-)(MODE)**. To enter TEACH mode, press the **(SELECT)(TEACH)** button and hold for longer than 2 seconds.

### Button Instructions

To enter **Loc** mode, hold **+** and press **-** four times. To enter **OLoc** mode, hold **+** and press **-** seven times.

Holding **+** and pressing **-** four times unlocks the sensor from either lock mode and the sensor displays **uLoc**.

### Remote Input Instructions

1. Access the remote input.

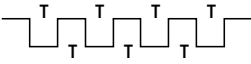
Action	Result
Four-pulse the remote input.	 The sensor is ready to have the button state defined and <b>btn</b> displays.

2. Lock or unlock the sensor buttons.

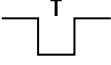
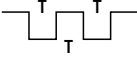
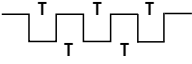
Action	Result
Single-pulse the remote input to unlock the sensor.	 <b>uLoc</b> displays and the sensor returns to Run mode.
Double-pulse the remote input to lock the sensor.	 <b>Loc</b> displays and the sensor returns to Run mode.
Triple-pulse the remote input to apply the operator lock to the sensor	 <b>OLoc</b> displays and the sensor returns to Run mode

## 3.5 TEACH Procedures

Use the following procedures to teach the sensor.

To cancel a TEACH procedure, press **TEACH** for longer than 2 seconds, or hold the remote input low for longer than 2 seconds. **ENCL** momentarily displays when a TEACH procedure is canceled.

### 3.5.1 Two-Point TEACH **2-PT**

Two-point TEACH sets the distance values associated with 0 V and 10 V (4 mA and 20 mA) based on taught target distances.

Figure 21. Two-Point TEACH

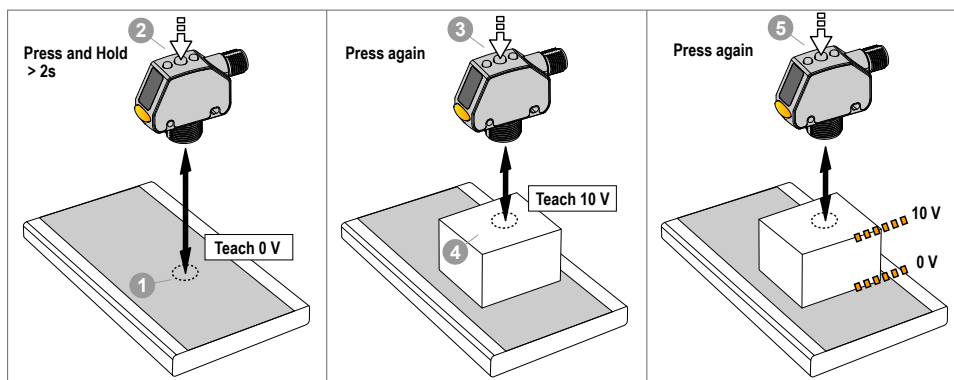



**Note:** The sensor must be set to **TECH = 2-Pt** to use the following instructions.



**Note:** To program the sensor using remote input, remote input must be enabled ( **1nPt = 5Et** ).

1. Present the target.

Method	Action	Result
Push Button	Present the first target. The sensor-to-target distance must be within the sensor's range.	The target's measurement value displays.
Remote Input		

2. Start the TEACH mode.

Method	Action	Result
Push Button	Press and hold <b>TEACH</b> for longer than 2 seconds.	<b>5Et</b> and <b>0 V</b> flash alternately on the display. The 2-Pt indicator flashes.
Remote Input	Single-pulse the remote input. 	

3. Teach the sensor.

Method	Action	Result
Push Button	Press <b>TEACH</b> to teach the target.	The measurement value flashes briefly, and the sensor is taught the first target. <b>5Et</b> and <b>10 V</b> flash alternately on the display. The 2-Pt indicator flashes.
Remote Input	Single-pulse the remote input. 	

It is possible to skip teaching the 0 V (4 mA) point and continue to use the existing setting. When using the push button, hold  for four seconds. The sensor displays SAVE and then flashes the existing value. When using the remote input, double-pulse the remote input.

4. Present the target.

Method	Action	Result
Push Button	Present the second target. The sensor-to-target distance must be within the sensor's range.	<b>5Et</b> and <b>10 V</b> flash alternately on the display. The 2-Pt indicator flashes.
Remote Input		

5. Teach the sensor.

Method	Action	Result
Push Button	Press <b>TEACH</b> to teach the target.	The new switch point flashes rapidly and the sensor returns to Run mode.
Remote Input	Single-pulse the remote input. 	



**Note:** If the same target is taught both times, **Lo** and **SPAN** flash alternately on the display, the 10 V (20 mA) value is automatically adjusted to maintain the minimum window size, the new distance quickly flashes four times, and the sensor returns to Run mode.

It is possible to skip teaching the 10 V (20 mA) point and continue to use the existing setting. When using the push button, hold  for four seconds. The sensor displays SAVE and then flashes the existing value. When using the remote input, double-pulse the remote input.

### 3.5.2 One-Point TEACH **1-Pt**

One-point TEACH mode defines the span of the analog output. One-point TEACH also defines the 5 V (12 mA) midpoint of the analog output to center the analog output around a reference target position.

Refer to [Manual Adjustments in One-Point TEACH Mode](#) on page 17 for more information.

Figure 22. One-Point Window

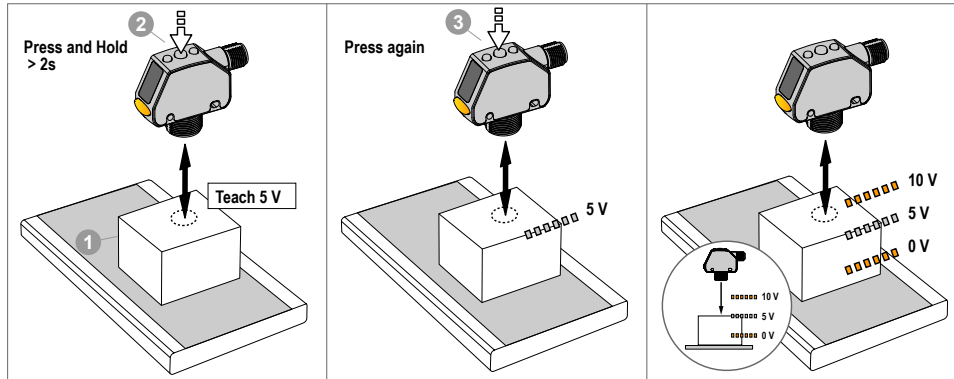

**Note:** The sensor must be set to `1-Pt = 1-Pt` to use the following instructions.

**Note:** To program the sensor using remote input, remote input must be enabled ( `1-Pt = 5Et` ).

1. Present the target.

Method	Action	Result
<b>Push Button</b> <b>Remote Input</b>	Present the first target. The sensor-to-target distance must be within the sensor's range.	The target's measurement value displays.

2. Start the TEACH mode.

Method	Action	Result
<b>Push Button</b>	Press and hold <b>TEACH</b> for longer than 2 seconds.	<code>5Et</code> and <code>5 V</code> flash alternately on the display. The 1-Pt indicator flashes.
<b>Remote Input</b>	No action required.	N/A

3. Teach the sensor.

Method	Action	Result
<b>Push Button</b>	Press <b>TEACH</b> to teach the target.	The measurement value flashes briefly, and the sensor returns to Run mode.
<b>Remote Input</b>	Single-pulse the remote input. 	

### 3.6 Sync Master/Slave

Two Q4X sensors may be used together in a single sensing application.

To eliminate crosstalk between the two sensors, configure one sensor to be the master and one to be the slave. In this mode, the sensors alternate taking measurements and the response speed doubles.



**Important:** The master sensor and the slave sensor must be programmed for the same Base Response Speed setting. The master sensor and slave sensor must share a common power source.

1. Configure the first sensor as the master; navigate: `1-Pt > MSt` .
2. Configure the second sensor as the slave; navigate: `1-Pt > SLvE` .
3. Connect the gray (input) wires of the two sensors together.

# 4 Specifications

**Sensing Beam using Visible red Class 1 laser, 655 nm**

≤ 510 mm models: IEC 60825-1:2007 Class 1  
 > 510 mm models: IEC 60825-1:2014 Class 1

**Supply Voltage (Vcc)**

12 V DC to 30 V DC

**Power and Current Consumption, exclusive of load**

< 675 mW

**Sensing Range—Threaded Barrel Models**

**600 mm models:** 25 mm to 600 mm (0.98 in to 23.62 in)  
**500 mm models:** 25 mm to 500 mm (0.98 in to 19.68 in)  
**300 mm models:** 25 mm to 300 mm (0.98 in to 11.81 in)  
**100 mm models:** 25 mm to 100 mm (0.98 in to 3.94 in)

**Sensing Range—Flush Mount Models**

**610 mm models:** 35 mm to 610 mm (1.38 in to 24.02 in)  
**310 mm models:** 35 mm to 310 mm (1.38 in to 12.20 in)  
**110 mm models:** 35 mm to 110 mm (1.38 in to 4.33 in)

**Analog Output Configuration**

0 V to 10 V or 4 mA to 20 mA, depending on model

**Output Rating**

**Analog Voltage Outputs (Q4X..U Models):** 2.5 kOhm minimum load resistance

**Analog Current Outputs (Q4X..I Models):** 1 kΩ maximum load resistance at 24 V; maximum load resistance = [(Vcc – 4.5)/0.02 Ω]

**Remote Input**

**Allowable Input Voltage Range:** 0 to Vcc  
**Active Low (internal weak pullup—sinking current):** Low State < 2.0 V at 1 mA max.

**Supply Protection Circuitry**

Protected against reverse polarity and transient overvoltages

**Analog Resolution—Threaded Barrel Models**

**300 mm and 600 mm models:**  
 25 mm to 100 mm: < 0.3 mm  
 100 mm to 300 mm: < 1 mm  
**500 mm models only:** 300 to 500 mm: < 1.75 mm  
**600 mm models only:** 300 to 600 mm: < 2 mm  
**100 mm models:** 25 mm to 100 mm: < 0.15 mm

**Analog Resolution—Flush Mount Models**

**610 mm models:** 310 to 610 mm: < 2 mm  
**310 mm models:**  
 35 mm to 110 mm: < 0.3 mm  
 110 mm to 310 mm: < 1 mm  
**110 mm models:** 35 mm to 110 mm: < 0.15 mm

**Beam Spot Size—100/110 mm Models**

Table 9: Beam Spot Size—100/110 mm Models

Distance (mm)		Size (Horizontal × Vertical)
Threaded Barrel Models	Flush Mount Models	
25	35	2.4 mm × 1.0 mm
50	60	2.2 mm × 0.9 mm
100	110	1.8 mm × 0.7 mm

**Analog Linearity**

Analog linearity performance matches accuracy performance curve (see [Performance Curves—Threaded Barrel Models](#) on page 26 and [Performance Curves—Flush Mount Models](#) on page 28).  
 On 600 mm and 610 mm models, linearity is the lesser of accuracy or 2.5% of full scale range

**Response Speed**

Total response speed varies from 0.5 ms to 2560 ms, depending on base measurement rate and averaging settings.  
 See [Averaging](#) on page 10 for more information.

**Delay at Power Up**

< 750 ms

**Ambient Light Immunity**

> 5,000 lux at 300 mm  
 > 2,000 lux at 500 mm

**Maximum Torque**

**Side mounting:** 1 N·m (9 in·lbs)  
**Nose mounting:** 20 N·m (177 in·lbs)

**Connector**

Integral 5-pin M12 male quick-disconnect connector

**Construction**

**Housing:** 316 L stainless steel  
**Lens cover:** PMMA acrylic  
**Lightpipe and display window:** polysulfone

**Chemical Compatibility**

Compatible with commonly used acidic or caustic cleaning and disinfecting chemicals used in equipment cleaning and sanitation. ECOLAB® certified.  
 Compatible with typical cutting fluids and lubricating fluids used in machining centers

**Application Note**

For optimum performance, allow 10 minutes for the sensor to warm up

**Environmental Rating**

IP67 per IEC60529  
 IP68 per IEC60529  
 IP69K per DIN 40050-9  
 IP rating is dependent on proper cordset installation.

**Shock**

MIL-STD-202G, Method 213B, Condition I (100G 6x along X, Y, and Z axes, 18 shocks), with device operating

**Vibration**

MIL-STD-202G, Method 201A (Vibration: 10 Hz to 60 Hz, 0.06 inch (1.52 mm) double amplitude, 2 hours each along X, Y and Z axes), with device operating

**Storage Temperature**

–25 °C to +75 °C (–13 °F to +167 °F)

**Beam Spot Size—300/310 mm, 500 mm, and 600/610 Models**

Table 10: Beam Spot Size—300/310 mm, 500 mm, and 600/610 mm Models

Distance (mm)		Size (Horizontal × Vertical)
Threaded Barrel Models	Flush Mount Models	
25	35	2.6 mm × 1.0 mm
150	160	2.3 mm × 0.9 mm
300	310	2.0 mm × 0.8 mm
500	-	1.9 mm × 1.0 mm
600	610	1.9 mm × 1.0 mm

**Excess Gain using a 90% White Card—600/610 mm Models**

Table 11: **HIGH** Excess Gain ( **Std** Excess Gain <sup>3</sup> )

Response Speed (ms)	· at 25 mm (600 mm models) · at 35 mm (610 mm models)	· at 100 mm (600 mm models) · at 110 mm (610 mm models)	· at 300 mm (600 mm models) · at 310 mm (610 mm models)	· at 600 mm (600 mm models) · at 610 mm (610 mm models)
2	280	110	25	6
5	280	110	25	6
15	1000 (360)	400 (150)	80 (30)	20 (7)
25	2000 (1000)	800 (400)	160 (80)	40 (20)
50	4000 (2000)	1600 (800)	320 (160)	80 (40)

**Operating Conditions**

35% to 95% relative humidity

Vcc	Min. Ambient Temp (°C)	Max. Ambient Temp (°C)	
	All Models	Q4X...U (0–10V)	Q4X..I (4–20 mA)*
12	-10	50	50
24			45
30			40

\* For 4–20 mA models only: Max. Ambient Sensor Temp (°C) = 50 – (Vcc – 12)/2

**Required Overcurrent Protection**



**WARNING:** Electrical connections must be made by qualified personnel in accordance with local and national electrical codes and regulations.

Overcurrent protection is required to be provided by end product application per the supplied table. Overcurrent protection may be provided with external fusing or via Current Limiting, Class 2 Power Supply. Supply wiring leads < 24 AWG shall not be spliced. For additional product support, go to [www.bannerengineering.com](http://www.bannerengineering.com).

Supply Wiring (AWG)	Required Overcurrent Protection (Amps)
20	5.0
22	3.0
24	2.0
26	1.0
28	0.8
30	0.5

<sup>3</sup>

- **Std** excess gain available in 15 ms response speed only
- **Std** excess gain provides increased noise immunity

## Certifications



**Banner Engineering BV** Park Lane, Culliganlaan  
2F bus 3, 1831 Diegem, BELGIUM

---



**Turck Banner LTD** Blenheim House, Blenheim  
Court, Wickford, Essex SS11 8YT, Great Britain

---



Industrial  
Control  
Equipment  
3TJJ

Class 2 power  
UL Environmental Rating: Type 1

---



chemical compatibility certified

ECOLAB is a registered trademark of Ecolab USA Inc. All rights reserved.

## 4.1 FCC Part 15 Class A

---

This equipment has been tested and found to comply with the limits for a Class A digital device, pursuant to part 15 of the FCC Rules. These limits are designed to provide reasonable protection against harmful interference when the equipment is operated in a commercial environment. This equipment generates, uses, and can radiate radio frequency energy and, if not installed and used in accordance with the instruction manual, may cause harmful interference to radio communications. Operation of this equipment in a residential area is likely to cause harmful interference in which case the user will be required to correct the interference at his own expense.

## 4.2 Industry Canada

---

This device complies with CAN ICES-3 (A)/NMB-3(A). Operation is subject to the following two conditions: 1) This device may not cause harmful interference; and 2) This device must accept any interference received, including interference that may cause undesired operation.

Cet appareil est conforme à la norme NMB-3(A). Le fonctionnement est soumis aux deux conditions suivantes : (1) ce dispositif ne peut pas occasionner d'interférences, et (2) il doit tolérer toute interférence, y compris celles susceptibles de provoquer un fonctionnement non souhaité du dispositif.



### 4.3 Dimensions

All measurements are listed in millimeters [inches], unless noted otherwise.

Figure 23. Threaded Barrel Models

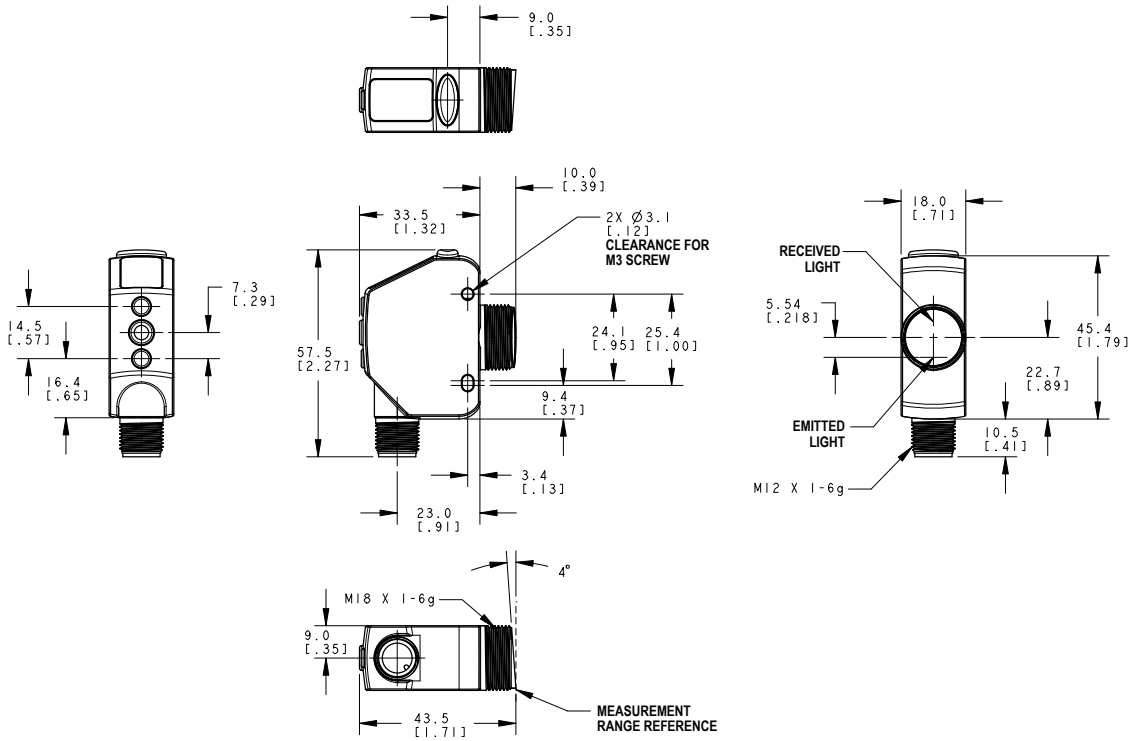
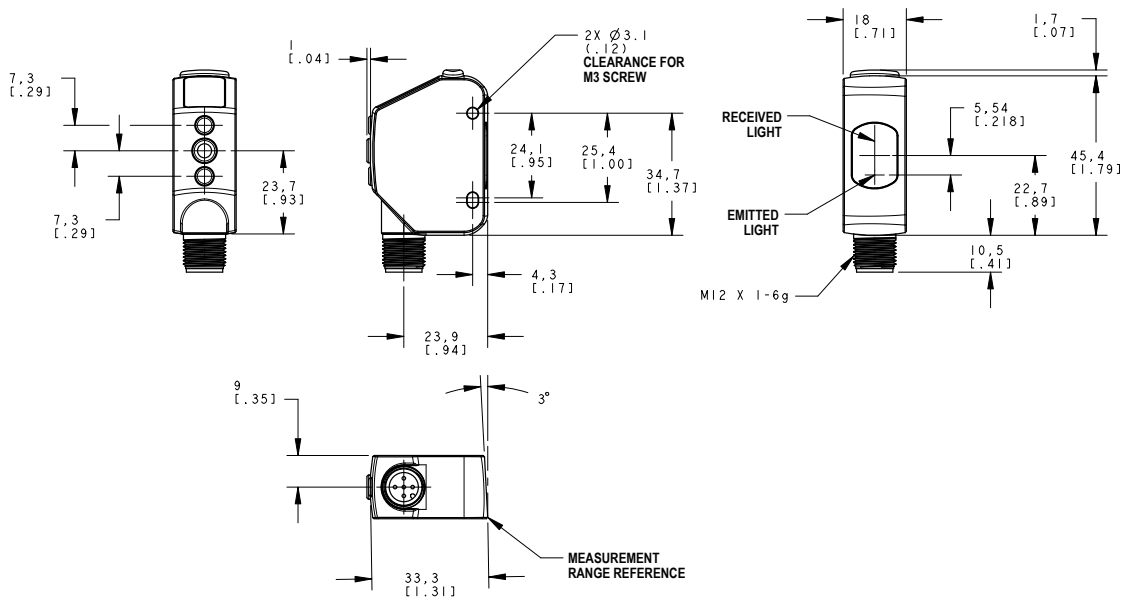

Figure 24. Flush Mount Models



## 4.4 Performance Curves—Threaded Barrel Models

### Accuracy (90% to 6% reflectance)

Figure 25. 100 mm Models

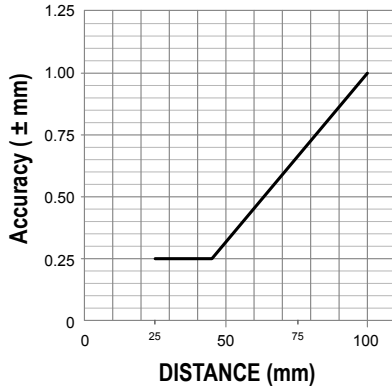

Figure 26. 300 mm Models

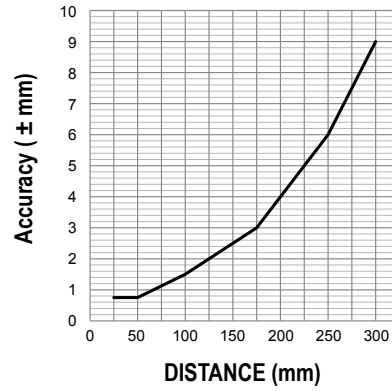

Figure 27. 500 mm Models

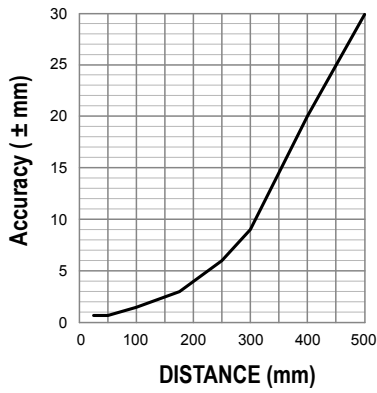
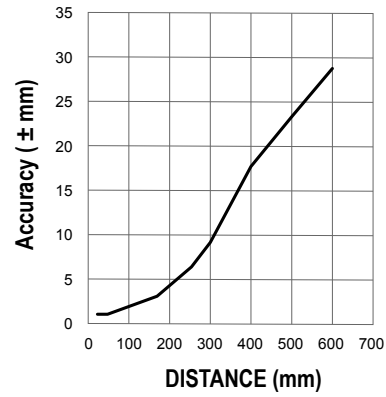

Figure 28. 600 mm Models



### Repeatability (90% to 6% reflectance)

Figure 29. 100 mm Models

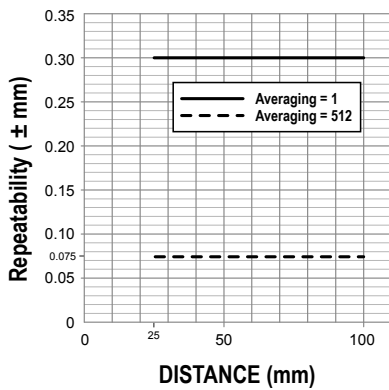
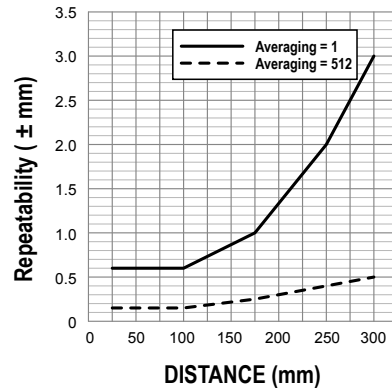

Figure 30. 300 mm Models



**Repeatability (90% to 6% reflectance)**

Figure 31. 500 mm Models

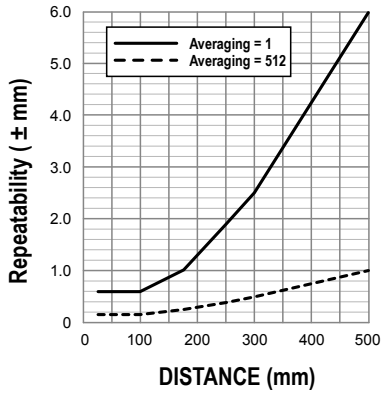
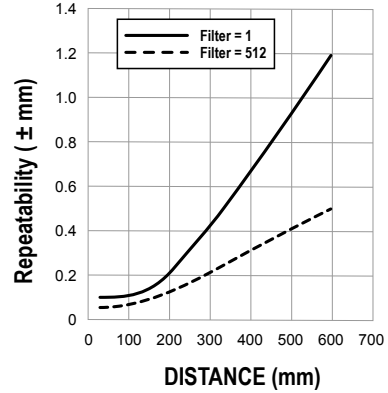

Figure 32. 600 mm Models



**Typical Temperature Effects <sup>4</sup>**

Figure 33. 100 mm and 300 mm Models

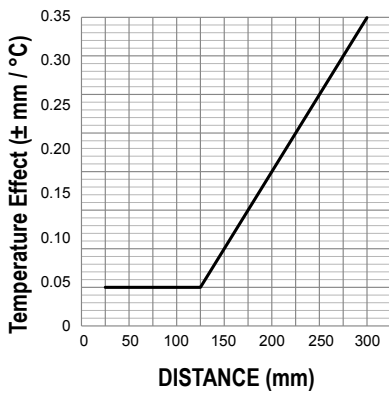

Figure 34. 500 mm Models

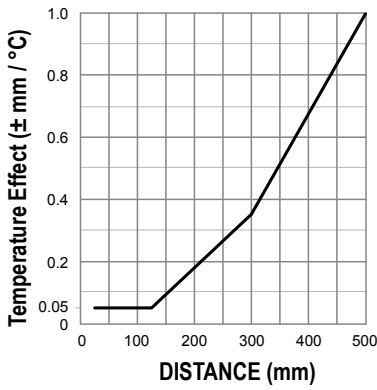
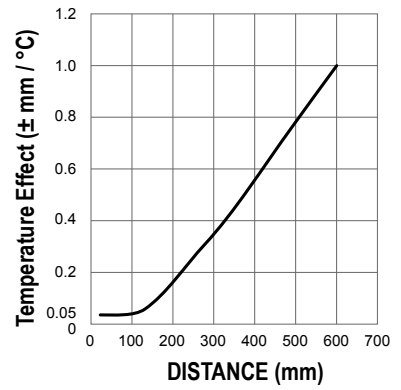
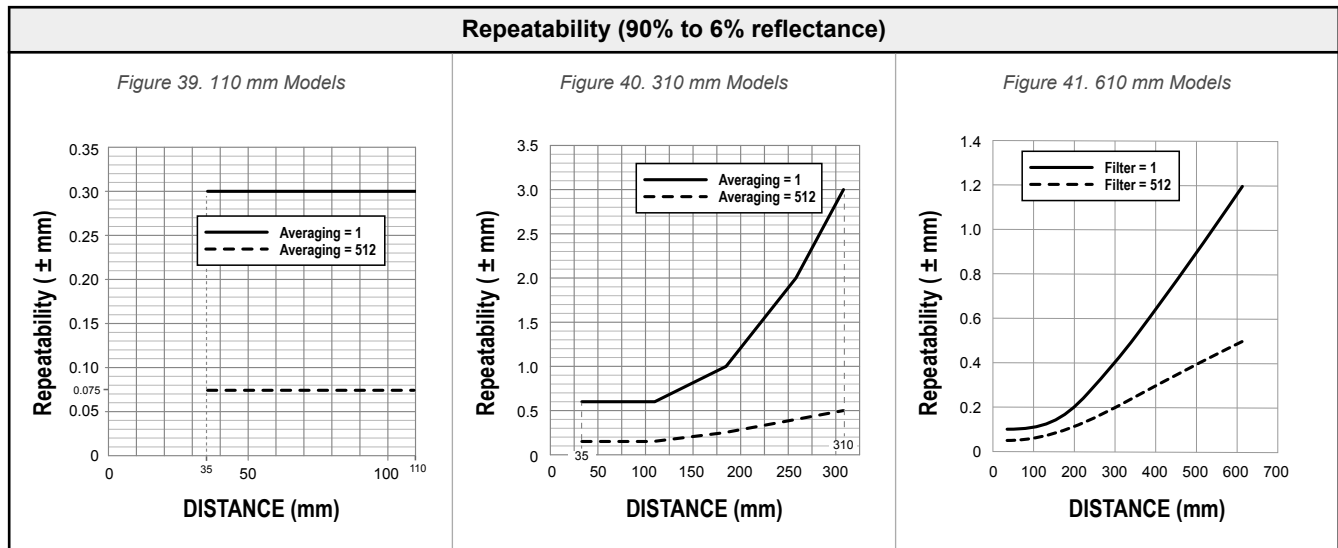
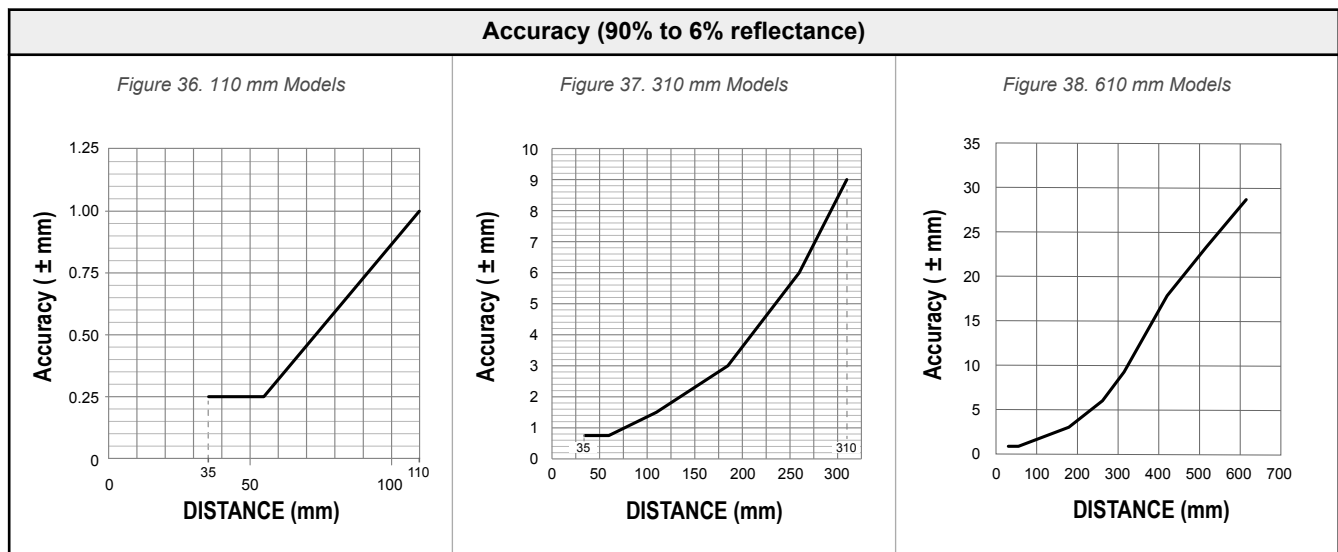

Figure 35. 600 mm Models



<sup>4</sup> Calculated as an average temperature effect across the sensor's full operating temperature.

## 4.5 Performance Curves—Flush Mount Models



**Typical Temperature Effects<sup>5</sup>**

Figure 42. 110 mm and 310 mm Models

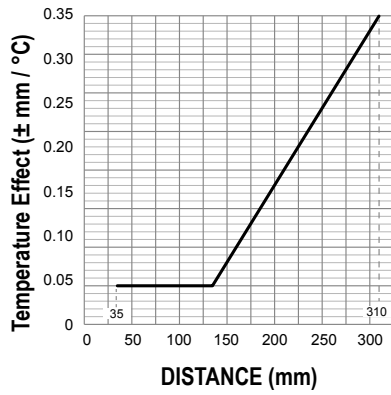
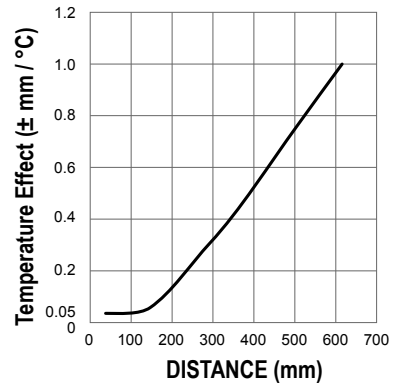

Figure 43. 610 mm Models



<sup>5</sup> Calculated as an average temperature effect across the sensor's full operating temperature.

## 5 Abbreviations

The following table describes the abbreviations used on the sensor display and in this manual.

Abbreviation	Description
----	No valid signal in range
1-Pt	One-point TEACH
2-Pt	Two-point TEACH
AUG	Average—Trigger output of Average measurement value
bot	Bottom
btn	Button
cncl	Cancel
disP	Display read
dist	Distance
End	End—exit the sensor menu
FAR	Far zero reference location—the maximum range is 0 and the measurement increase as the target moves closer to the sensor
FLtr	Filter
Hi	Trigger output of maximum measurement value
Hold	Hold the last value
inPt	Input wire function
Lo	Trigger output of minimum measurement value
Loc	Lock/locked
LoFF	Laser off
LOS	Loss of signal
mA	milliAmp
MASt	Master
Min	Min
NEAR	Near zero reference location—the end of the barrel is 0 and the measurement increase as the target moves further away from the sensor
NEG	Negative slope
OLoc	Allows teaching and adjusting 0 V and 10 V (4 mA and 20 mA) settings, while locking out access to other sensor settings.
POS	Positive slope
range	Range—Hi to Lo
rSet	Reset to factory defaults
SAMP	Sample—Trigger output of a sampled measurement value

Abbreviation	Description
SET	Input wire = remote teach function
SHFT	Shift the Zero Reference Location after a TEACH
SLVE	Slave
SPAN	Span—analog window size
SPD	Response speed
TECH	TEACH process selection
THI	Trigger setting for tracking maximum measurement value
TL0	Trigger setting for tracking minimum measurement value
TRG	Trigger
TRIG	Trigger—Set the trigger type
V	Volt
ULOC	Unlock/unlocked
WWW	Saturated signal (too much light)
ZERO	Zero—select the zero reference location

## 6 Troubleshooting

Table 12: Troubleshooting Codes

Code	Description	Resolution
----	No valid signal in range	Reposition the sensor or the target
Lo SPAn	The adjusted or taught window size is smaller than the minimum window size.	The sensor automatically adjusts the window size to maintain the minimum window and completes the adjustment or the TEACH
rAnGE	The distance being taught is outside of the valid sensing range	Present a target within the sensor's range and re-TEACH.
uuuu	The signal is saturated (too much light)	Reposition the sensor or the target to increase the detection distance, or increase the angle of incidence between the sensor and the target
End	The adjusted or taught end point is between the other end point and the end of range. There is insufficient space to create the minimum window size.	TEACH or adjust the end points to maintain the minimum window size within the sensing range.

Table 13: Error Codes

Code	Description	Resolution
ErrE	EEPROM fault	Contact Banner Engineering to resolve
ErrL	Laser fault	Contact Banner Engineering to resolve
ErrC	Output short-circuited	Check the wiring for an electrical short circuit and to ensure that the wiring is correct
ErrS	System fault	Contact Banner Engineering to resolve



# 7 Accessories

## 7.1 Cordsets

All measurements are listed in millimeters, unless noted otherwise.

### Standard Cordsets

**Cable:** PVC jacket, PUR (polyurethane) connector body, nickel-plated brass coupling nut

**Environmental Rating:** IP67

5-Pin Threaded M12 Cordsets with Shield—Single Ended				
Model	Length	Style	Dimensions	Pinout (Female)
MQDEC2-506	2 m (6.56 ft)	Straight		
MQDEC2-515	5 m (16.4 ft)			
MQDEC2-530	9 m (29.5 ft)			
MQDEC2-550	15 m (49.2 ft)			
MQDEC2-575	23 m (75.44 ft)			
MQDEC2-5100	30.5 m (100 ft)			
MQDEC2-506RA	2 m (6.56 ft)	Right-Angle		<p>1 = Brown 2 = White 3 = Blue 4 = Black 5 = Gray</p>
MQDEC2-515RA	5 m (16.4 ft)			
MQDEC2-530RA	9 m (29.5 ft)			
MQDEC2-550RA	15 m (49.2 ft)			
MQDEC2-575RA	23 m (75.44 ft)			
MQDEC2-5100RA	31 m (101.68 ft)			

### 5-Pin Threaded M12 Cordsets—Washdown Stainless Steel

**Cable:** PVC jacket and over-mold, EPDM o-ring, 316L coupling nut

**Environmental Rating:** IP69K per DIN 40050-9

5-Pin Threaded M12 Stainless Steel Washdown Cordsets—Single Ended				
Model	Length	Style	Dimensions	Pinout (Female)
MQDC-WDSS-0506	2 m (6.56 ft)	Straight		
MQDC-WDSS-0515	5 m (16.4 ft)			
MQDC-WDSS-0530	9 m (29.5 ft)			

### 5-Pin Threaded M12 Cordsets—Washdown, with Shield

**Cable:** Polypropylene jacket and connector body, stainless steel coupling nut

**Environmental Rating:** IP68

5-Pin Threaded M12 Washdown Cordsets with Shield—Single Ended				
Model	Length	Style	Dimensions	Pinout (Female)
MQDCWD-506	2 m (6.56 ft)	Straight		
MQDCWD-530	9 m (29.5 ft)			

**4-Pin Female and 5-Pin Male Threaded M12 Cordset—Double Ended**

**Cable:** PVC jacket, PUR (polyurethane) connector body, nickel-plated brass coupling nut

**Conductors:** 20 AWG; No Shield

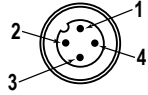
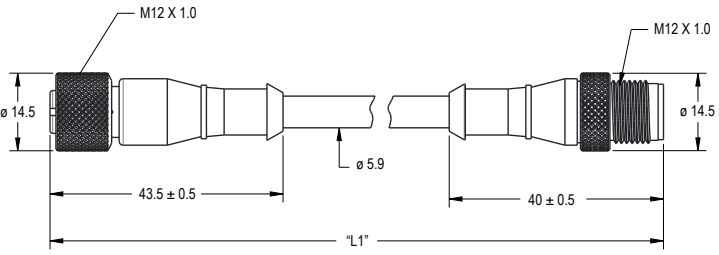
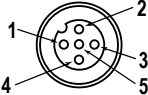
4-Pin Male and 5-Pin Female Threaded M12 Cordsets—Double Ended				
Model	Length "L1"	Style	Pinout	
MQDC-5401SS	0.30 m (0.98 ft)	Female Straight/ Male Straight	Male	
MQDC-5406SS	1.83 m (6.00 ft)		 <ul style="list-style-type: none"> <li>1 = Brown</li> <li>2 = White</li> <li>3 = Blue</li> <li>4 = Black</li> </ul>	
			<p>Female</p>  <ul style="list-style-type: none"> <li>1 = Brown</li> <li>2 = Not Used</li> <li>3 = Blue</li> <li>4 = Black</li> <li>5 = White</li> </ul>	

**5-Pin Male Threaded and 5-Pin Female Quick Disconnect M12 Cordset with Shield—Double Ended**

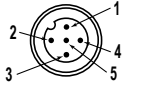
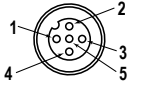
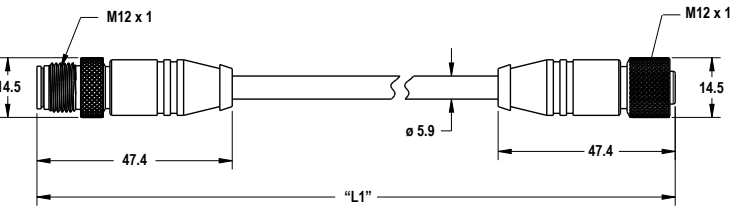
5-Pin Male Threaded and 5-Pin Female Quick Disconnect M12 Cordset with Shield—Double Ended				
Model	Length "L1"	Style	Pinout (Male)	Pinout (Female)
MQDEC3-503SS	0.91 m (2.99 ft)	Female Straight/Male Straight		
MQDEC3-506SS	1.83 m (6 ft)			
MQDEC3-515SS	4.58 m (15 ft)			
MQDEC3-530SS	9.2 m (30.2 ft)			
			<ul style="list-style-type: none"> <li>1 = Brown</li> <li>2 = White</li> <li>3 = Blue</li> </ul>	<ul style="list-style-type: none"> <li>4 = Black</li> <li>5 = Gray</li> </ul>

## 7.2 Brackets

All measurements are listed in millimeters, unless noted otherwise.

### SMBQ4X..

- Swivel bracket with tilt and pan movement for precision adjustment
- Easy sensor mounting to extruded rail T-slots
- Metric and inch size bolts available
- Side mounting of some sensors with the 3 mm screws included with the sensor

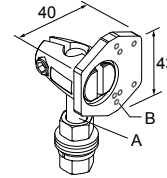

### A (Bolt Thread)

SMBQ4XF A = 3/8 - 16 × 2¼ inches

SMBQ4XFAM10 = M10 - 1.5 × 50

SMBQ4XFAM12 = n/a; no bolt included. Mounts directly to 12 mm (½ inch) rods

B = 7 × M3 × 0.5

### SMB18A

- Right-angle mounting bracket with a curved slot for versatile orientation
- 12-ga. stainless steel
- 18 mm sensor mounting hole
- Clearance for M4 (#8) hardware

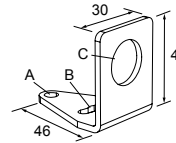

Hole center spacing: A to B = 24.2

Hole size: A = ø 4.6, B = 17.0 × 4.6, C = ø 18.5

### SMB18FA..

- Swivel bracket with tilt and pan movement for precision adjustment
- Easy sensor mounting to extruded rail T-slots
- Metric and inch size bolts available
- 18 mm sensor mounting hole

Hole size: B=ø 18.1

### Bolt Thread (A):

SMB18FA = 3/8 - 16 × 2 in

SMB18FAM10 = M10 - 1.5 × 50

SMB18FAM12 = n/a; no bolt included. Mounts directly to 12 mm (½ in) rods

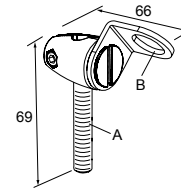

### SMBAMS18P

- Flat SMBAMS series bracket with 18 mm hole
- Articulation slots for 90+° rotation
- 12-ga. (2.6 mm) cold-rolled steel

Hole center spacing: A = 26.0, A to B = 13.0

Hole size: A = 26.8 × 7.0, B = ø 6.5, C = ø 19.0

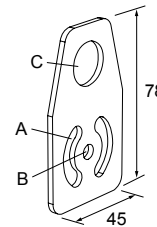

### SMBAMS18RA

- Right-angle SMBAMS series bracket with 18 mm hole
- Articulation slots for 90+° rotation
- 12-ga. (2.6 mm) cold-rolled steel

Hole center spacing: A = 26.0, A to B = 13.0

Hole size: A = 26.8 × 7.0, B = ø 6.5, C = ø 19.0

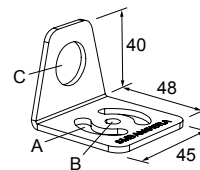

## 7.3 Aperture Kits—Threaded Barrel Models

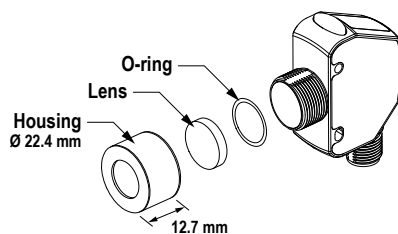

---

**APG18S**

Kit with glass lens to protect plastic sensor lens from chemical environments and weld splatter damage.

Used with S18, M18, T18, TM18, and Q4X



### Additional Information

- Borosilicate glass window protects the PMMA window from weld splatter and chemicals
- Adds 4.8 mm to the length of the threaded barrel
- Reduces excess gain by 30%; increase the response time to restore excess gain

## 8 Product Support and Maintenance

### 8.1 Cleaning and Maintenance

---

Clean the sensor when soiled and use with care.

Handle the sensor with care during installation and operation. Sensor windows soiled by fingerprints, dust, water, oil, etc. may create stray light that may degrade the peak performance of the sensor. Blow the window clear using filtered, compressed air, then clean as necessary using only water and a lint-free cloth.

### 8.2 Contact Us

---

Banner Engineering Corp. headquarters is located at:

9714 Tenth Avenue North  
Minneapolis, MN 55441, USA  
Phone: + 1 888 373 6767

For worldwide locations and local representatives, visit [www.bannerengineering.com](http://www.bannerengineering.com).

### 8.3 Banner Engineering Corp. Limited Warranty

---

Banner Engineering Corp. warrants its products to be free from defects in material and workmanship for one year following the date of shipment. Banner Engineering Corp. will repair or replace, free of charge, any product of its manufacture which, at the time it is returned to the factory, is found to have been defective during the warranty period. This warranty does not cover damage or liability for misuse, abuse, or the improper application or installation of the Banner product.

**THIS LIMITED WARRANTY IS EXCLUSIVE AND IN LIEU OF ALL OTHER WARRANTIES WHETHER EXPRESS OR IMPLIED (INCLUDING, WITHOUT LIMITATION, ANY WARRANTY OF MERCHANTABILITY OR FITNESS FOR A PARTICULAR PURPOSE), AND WHETHER ARISING UNDER COURSE OF PERFORMANCE, COURSE OF DEALING OR TRADE USAGE.**

This Warranty is exclusive and limited to repair or, at the discretion of Banner Engineering Corp., replacement. **IN NO EVENT SHALL BANNER ENGINEERING CORP. BE LIABLE TO BUYER OR ANY OTHER PERSON OR ENTITY FOR ANY EXTRA COSTS, EXPENSES, LOSSES, LOSS OF PROFITS, OR ANY INCIDENTAL, CONSEQUENTIAL OR SPECIAL DAMAGES RESULTING FROM ANY PRODUCT DEFECT OR FROM THE USE OR INABILITY TO USE THE PRODUCT, WHETHER ARISING IN CONTRACT OR WARRANTY, STATUTE, TORT, STRICT LIABILITY, NEGLIGENCE, OR OTHERWISE.**

Banner Engineering Corp. reserves the right to change, modify or improve the design of the product without assuming any obligations or liabilities relating to any product previously manufactured by Banner Engineering Corp. Any misuse, abuse, or improper application or installation of this product or use of the product for personal protection applications when the product is identified as not intended for such purposes will void the product warranty. Any modifications to this product without prior express approval by Banner Engineering Corp will void the product warranties. All specifications published in this document are subject to change; Banner reserves the right to modify product specifications or update documentation at any time. Specifications and product information in English supersede that which is provided in any other language. For the most recent version of any documentation, refer to: [www.bannerengineering.com](http://www.bannerengineering.com).

For patent information, see [www.bannerengineering.com/patents](http://www.bannerengineering.com/patents).

# Index

## **B**

buttons 18

## **C**

cleaning 37

## **D**

default settings 18

display 15

display view 15

## **E**

end 15

exit setup mode 15

## **F**

factory default 16, 18

far 12

## **I**

input wire function 14

invert display 15

## **L**

locking sensor buttons 18

loss of signal 13

## **M**

maintenance 37

master 21

## **N**

near 12

## **P**

programming the sensor 8, 10,  
12–21

pulse 17, 18

## **R**

remote input 17, 18

reset 16

rset 16

## **S**

sensor programming 8, 10, 12–21

signal loss 13

slave 21

slope 12

sync 21

## **T**

TEACH mode 18–20

trigger 14

## **U**

unlock sensor buttons 18

## **Z**

zero reference location 12