

- NOTE :
- MATERIAL :
HOUSING : LCP, BLACK, UL94V-0
TERMINAL : COPPER ALLOY THICKNESS = 0.15 MM
SHIELD CASE : STAINLESS STEEL THICKNESS = 0.30 MM
 - PLATING :
TERMINAL: CONTACT AREA : GOLD FLASH (0.11 MICRON MIN.) OVER
MINIMUM 0.75 MICRON Pd/Ni.
SOLDER TAIL AREA : GOLD FLASH (0.05 MICRON MIN.).
UNDER PLATING : NICKEL 2.0 MICROMN MINIMUM.
SHIELD : SEE CHART
UNDER PLATING : NICKEL 1.27 MICRON MINIMUM.
 - TAIL COPLANARITY 0.08 MM MAXIMUM.
 - PRODUCT SPEC. : PS-47642-001 ; PACKING SPEC. : PK-47654-001
 - COMPLIANT TO RoHS DIRECTIVE 2002/95/EC AND ELV DIRECTIVE 2000/53/EC.

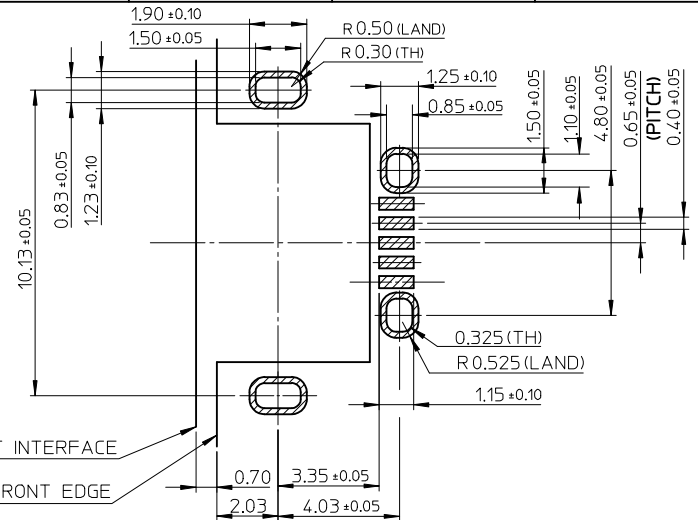

RECOMMENDED PCB LAYOUT (Thickness=0.6mm~1.2mm)

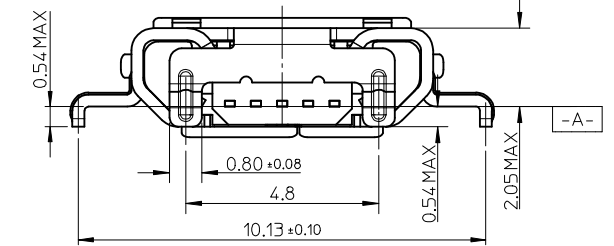

47665-0001	1.27 MICRON MATTE TIN
47665-0002	0.4 MICRON BLACK NICKEL
PART NUMBER	SHELL PLATING

NEW PRODUCT EC NO: 2009/08/21 DRWN: XJSONG CHKD: XJSONG APPR: 2009/08/21	QUALITY SYMBOLS ▽=0 ◻=0	GENERAL TOLERANCES (UNLESS SPECIFIED)		DIMENSION STYLE MM ONLY		SCALE 1:1	DESIGN UNITS METRIC	THIRD ANGLE PROJECTION		
		mm	INCH	DRAWN BY XJSONG	DATE 2008/12/23	TITLE MICRO USB B REC. SINK TYPE				
		4 PLACES ± ---	± ---	CHECKED BY JTIAN	DATE 2008/12/23	MOLEX INCORPORATED				
		3 PLACES ± ---	± ---	APPROVED BY HWWANG	DATE 2008/12/23					
2 PLACES ± 0.15	± ---	ANGULAR ± 3 °		MATERIAL NO.	DOCUMENT NO.	SD-47665-001				
1 PLACE ± 0.25	± ---	DRAFT WHERE APPLICABLE MUST REMAIN WITHIN DIMENSIONS		SIZE A3	THIS DRAWING CONTAINS INFORMATION THAT IS PROPRIETARY TO MOLEX INCORPORATED AND SHOULD NOT BE USED WITHOUT WRITTEN PERMISSION					

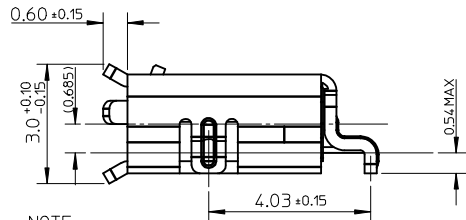
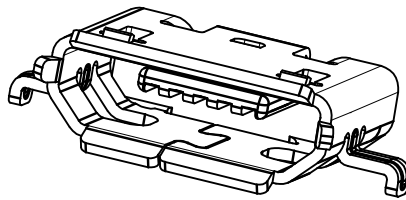
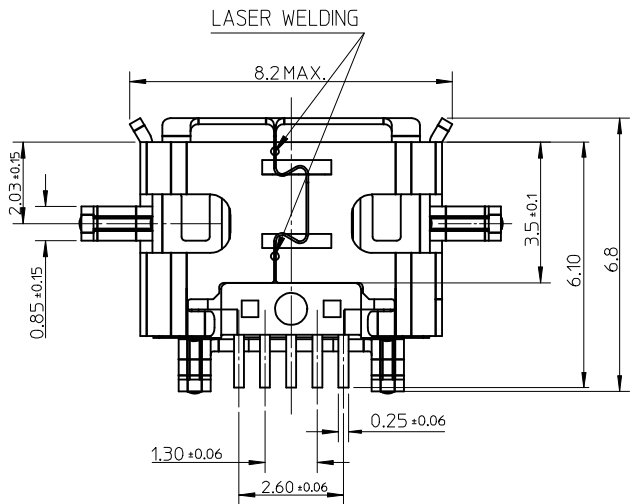
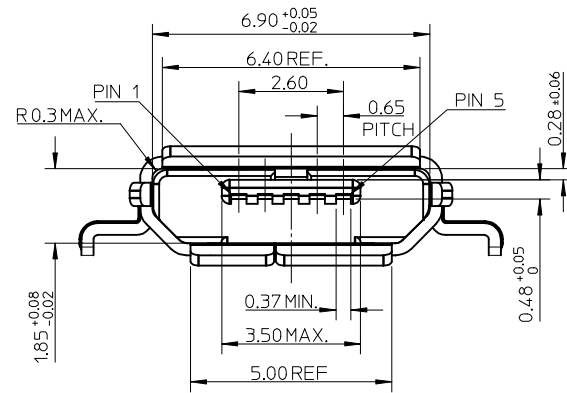
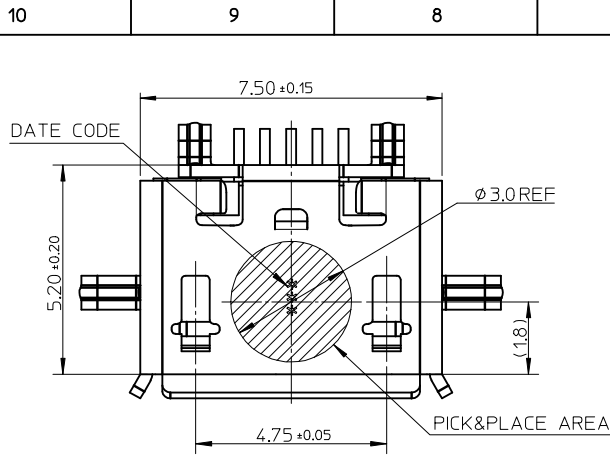

- NOTE :
- MATERIAL :
HOUSING : LCP, BLACK, UL94V-0
TERMINAL : COPPER ALLOY THICKNESS = 0.15 MM
SHIELD CASE : STAINLESS STEEL THICKNESS = 0.30 MM
 - PLATING :
TERMINAL: CONTACT AREA : GOLD FLASH (0.11 MICRON MIN.) OVER
MINIMUM 0.75 MICRON Pd/Ni.
SOLDER TAIL AREA : GOLD FLASH (0.05 MICRON MIN.).
UNDER PLATING : NICKEL 2.0 MICROMN MINIMUM.
SHIELD : SEE CHART
UNDER PLATING : NICKEL 1.27 MICRON MINIMUM.
 - TAIL COPLANARITY 0.08 MM MAXIMUM.
 - PRODUCT SPEC. : PS-47642-001 ; PACKING SPEC. : PK-47654-001
 - COMPLIANT TO RoHS DIRECTIVE 2002/95/EC AND ELV DIRECTIVE 2000/53/EC.

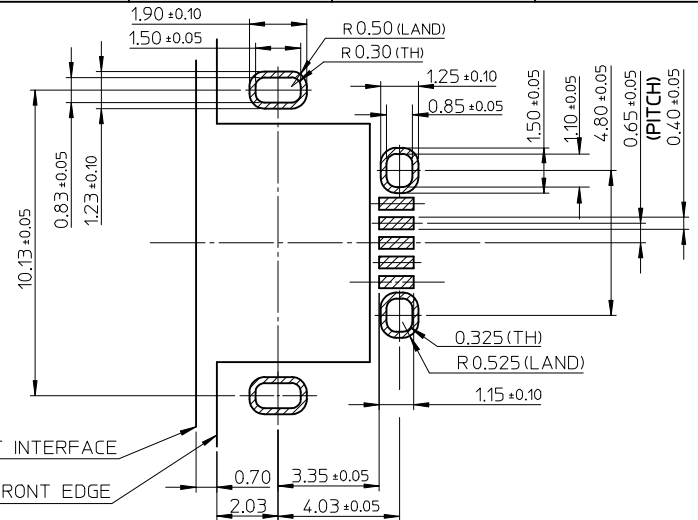

RECOMMENDED PCB LAYOUT (Thickness=0.6mm~1.2mm)

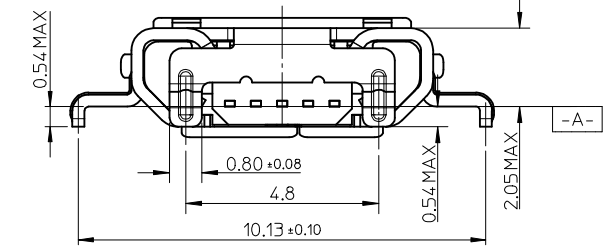

47665-0001	1.27 MICRON MATTE TIN
47665-0002	0.4 MICRON BLACK NICKEL
PART NUMBER	SHELL PLATING

NEW PRODUCT EC NO: 2009/08/21 DRWN: XJSONG CHKD: XJSONG APPR: 2009/08/21	QUALITY SYMBOLS ▽=0 ◻=0	GENERAL TOLERANCES (UNLESS SPECIFIED)		DIMENSION STYLE MM ONLY		SCALE 1:1	DESIGN UNITS METRIC	THIRD ANGLE PROJECTION		
			mm	INCH	DRAWN BY XJSONG	DATE 2008/12/23	TITLE MICRO USB B REC. SINK TYPE			
		4 PLACES	± ---	± ---	CHECKED BY JTIAN	DATE 2008/12/23	MOLEX INCORPORATED			
		3 PLACES	± ---	± ---	APPROVED BY HWWANG	DATE 2008/12/23				
2 PLACES	± 0.15	± ---	MATERIAL NO. SEE CHART		DOCUMENT NO. SD-47665-001		SHEET NO. 1 OF 1			
1 PLACE	± 0.25	± ---	DRAFT WHERE APPLICABLE MUST REMAIN WITHIN DIMENSIONS							
SIZE A3		THIS DRAWING CONTAINS INFORMATION THAT IS PROPRIETARY TO MOLEX INCORPORATED AND SHOULD NOT BE USED WITHOUT WRITTEN PERMISSION								