

6

5

4

3

2

1

PART NUMBER	ENGINEERING NO.	LENGTH ± TOLERANCE
1300480046	E10A00610M010	3' 3" +2.19"/-0" [1M +55.6/-0 mm]
1300480048	E10A00610M050	16' 4" +6.5"/-0" [5M +165.0/-0 mm]

AUX VIEW
SCALE 1:4

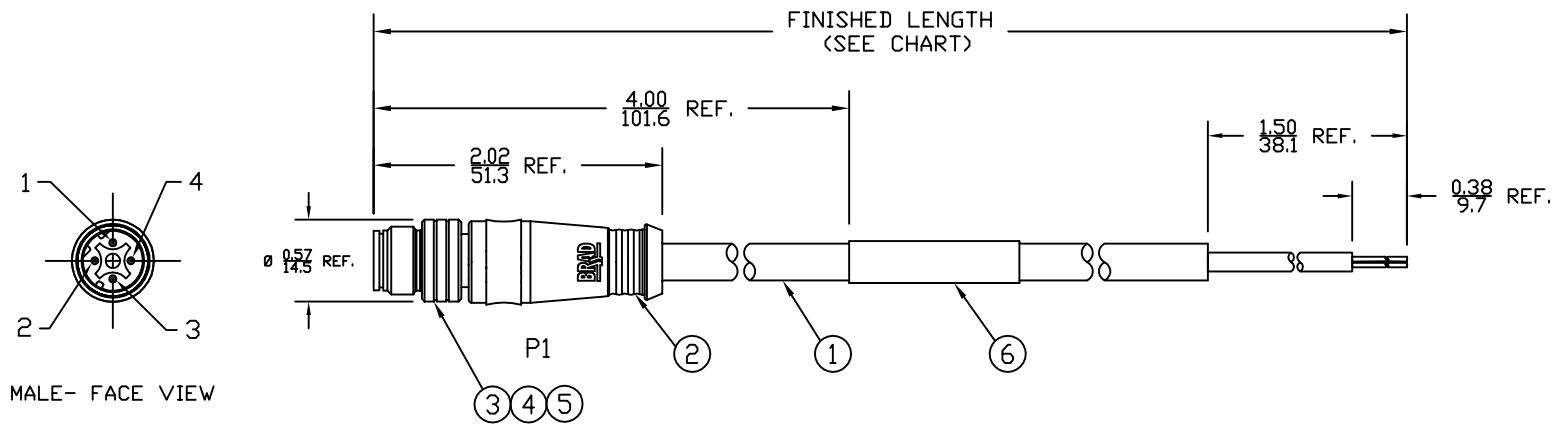
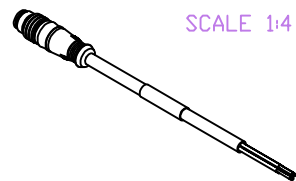

P1	
1	YELLOW
2	WHITE
3	ORANGE
4	BLUE

WIRING DIAGRAM

- NOTES:
- 1) MATERIAL: SEE TABLE
 - 2) FINISHES: SEE TABLE
 - 3) CABLE: #22/4 SHIELDED PUR
 - 4) ELECTRICAL DATA:
ACCORDING TO CAT5e ETHERNET STANDARD
MAX. VOLTAGE: 30V
MAX. CURRENT 1.5A
 - 5) ENVIRONMENTAL:
PROTECTION IP67
TEMPERATURE RANGE: -20°C TO 75°C
 - 6) WRAP LABEL IS MARKED WITH P/N, DATE CODE,
VOLTAGE & AMPERAGE.
 - 7) ASSEMBLY IS RoHS COMPLIANT.

ITEM	QTY.	DESCRIPTION	MATERIAL	FINISH
6	1	LABEL	PLASTIC FILM	BLACK/YELLOW
5	1	INSERT	PUR	BLACK
4	4	PIN CONTACT	COPPER ALLOY	GOLD PLATED
3	1	M12 COUPLING NUT	BRASS	NICKEL
2	1	OVERMOLD	PUR	BLACK
1	1	ETHERNET CABLE-CAT5E	PUR JACKET	TEAL

SD RELEASE
EC NO: MEL2010-0005
7/10/09
DRWN: VOU
CHKD: BWOODMAN
APPR: JFMURPHY 2009/07/20

QUALITY SYMBOLS
▽=0
▽C=0

GENERAL TOLERANCES (UNLESS SPECIFIED)

	mm	INCH
4 PLACES	±----	±----
3 PLACES	±----	±.005
2 PLACES	±----	±.010
1 PLACE	±----	±.020

ANGULAR ± 1/2°

DRAFT WHERE APPLICABLE
MUST REMAIN
WITHIN DIMENSIONS

DIMENSION STYLE
IN/MM

DRAWN BY: VOU
DATE: 2009/07/06

CHECKED BY: BWOODMAN
DATE: 2009/07/31

APPROVED BY: ---
DATE: ---

MATERIAL NO.
SEE CHART

SIZE
A

SCALE 3:4

DESIGN UNITS INCH

THIRD ANGLE PROJECTION

TITLE
MICRO-CHANGE CABLE ASSY
4P M/MP ST D-CODE
#22/4 SHIELDED PUR

MOLEX INCORPORATED

DOCUMENT NO. SD-120108-014

SHEET NO. 1 OF 1

THIS DRAWING CONTAINS INFORMATION THAT IS PROPRIETARY TO MOLEX INCORPORATED AND SHOULD NOT BE USED WITHOUT WRITTEN PERMISSION

6

5

4

3

2

1