

REVISIONS				
P.	LTN	DESCRIPTION	DATE	APP'D
C		REVISED PER ECO-16-005492	11APR2016	DLD WEM
C1		REVISED PER ECO-16-012869	31AUG2016	DLD WEM

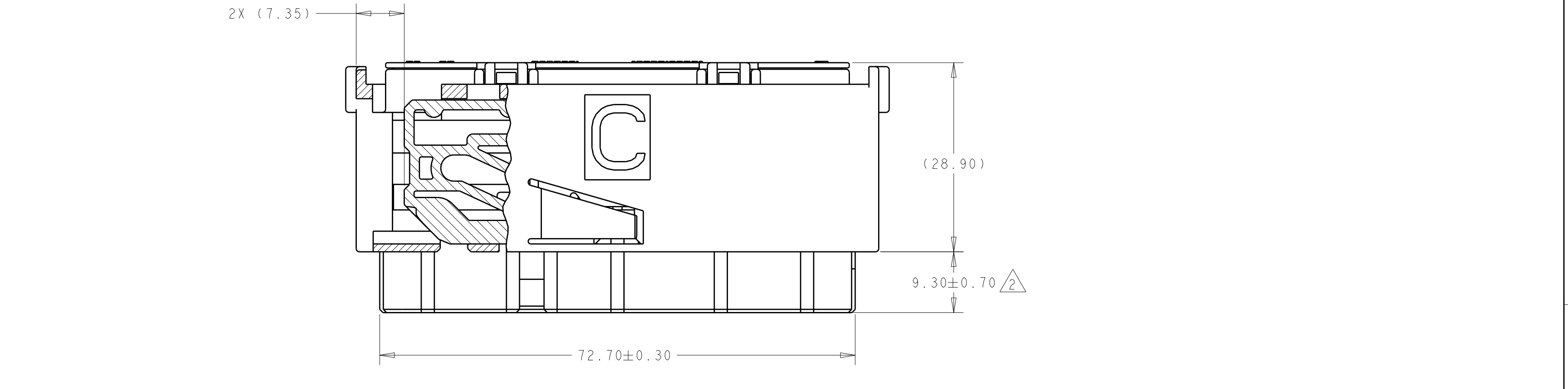

- 1. PLUG HOUSING AND SEAL COVER: NYLON 6/6, BLACK. TPA: NYLON 6/6, COLOR - SEE TABLE. MATTE WIRE SEAL: SILICONE, LIGHT BLUE. PERIPHERAL SEAL: SILICONE, GREEN. ALPHA SLIDE: NYLON 6/6, BLUE. BETA SLIDE: NYLON 6/6, GREEN.
- 2. TPA SHOWN IN PRE-LATCHED, AS SHIPPED, POSITION.
- 3. TPA SHOWN IN CLOSED POSITION.
- 4. SEE TABLE ON SHEET 2 FOR SEAL COVER PIN OUT CONFIGURATION.
- 5. PLUG ASSEMBLY MATES WITH TE CONNECTIVITY INTERFACE DRAWING 1924771-INT, POLARIZATION E.
- 6. PLUG ASSEMBLY WILL ACCEPT THE FOLLOWING GET TERMINAL PART NUMBERS: 1393364-1 (GOLD 22AWG; 0.35mm²) 1393365-1 (GOLD 18-20AWG; 0.75mm²-0.5mm²) 1924878-1 (TIN/SILVER 22AWG; 0.35mm²) 1924879-1 (TIN/SILVER 18-20AWG; 0.75mm²-0.5mm²) 1924782-1 (TIN/SILVER 1.0mm²) 1924880-1 (TIN/SILVER 16AWG; 1.5mm²)
- 7. WIRE DRESS ASSEMBLY MUST BE INSTALLED ONTO PLUG ASSEMBLY WITH LEVER IN LOCKED POSITION.
- 8. APPLICATION SPEC'S: 408-10229, 408-10230.
- 9. NOTE DELETED.
- 10. FORCE TO SEAT TPA COMPONENT FROM PRE-SET TO LOCKED (FULLY LOADED W/ TERMINALS) TO BE 83N MAX.
- 11. FORCE TO MOVE TPA FROM FULLY LOCKED TO PRE-SET TO BE 115N MAX. FLAT BLADE SCREWDRIVER SUGGESTED FOR REMOVAL OF TPA

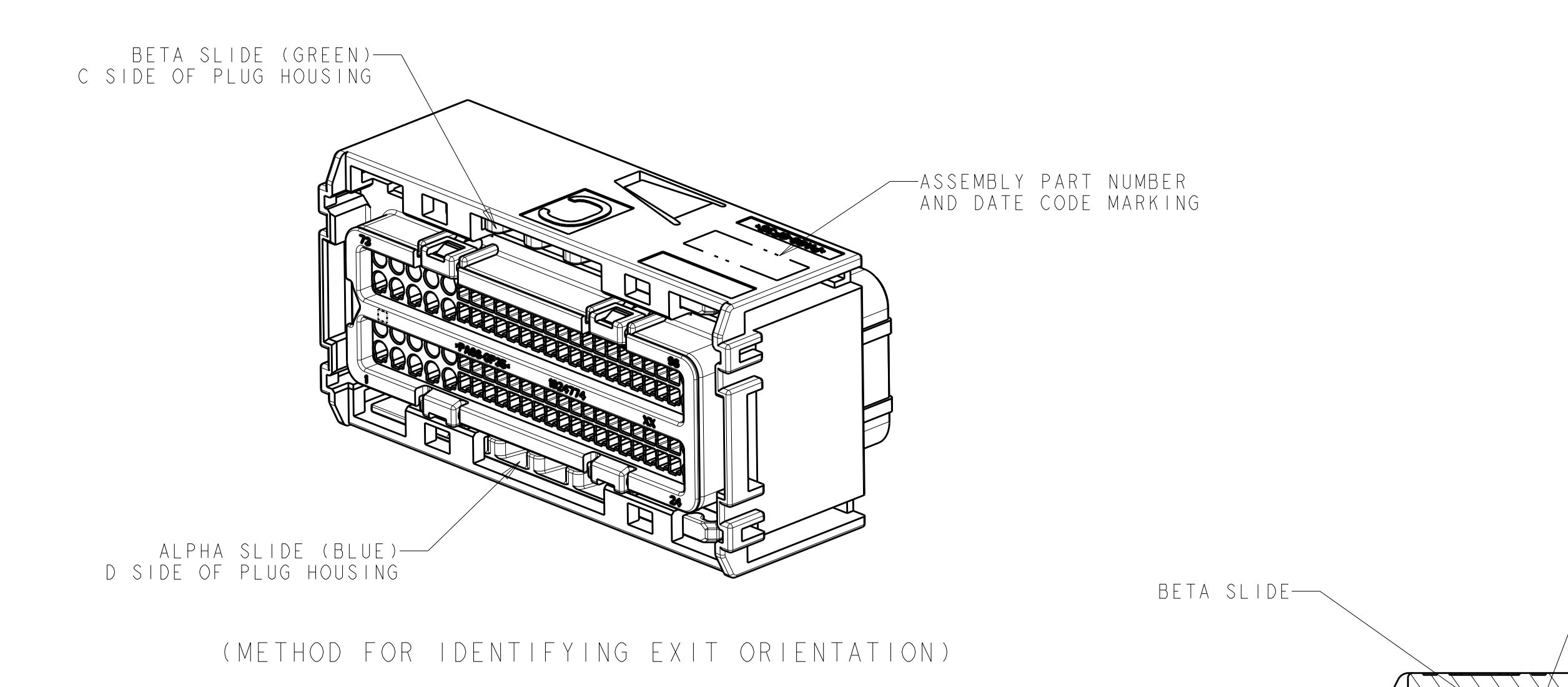
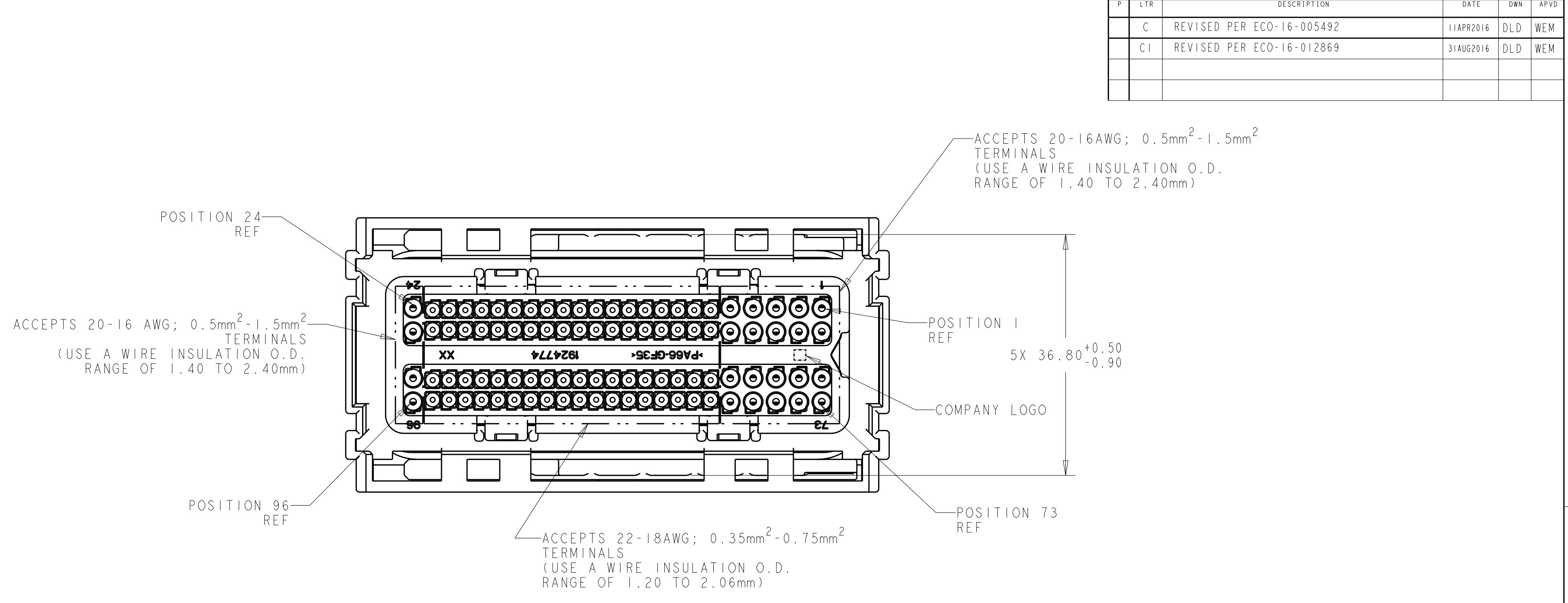
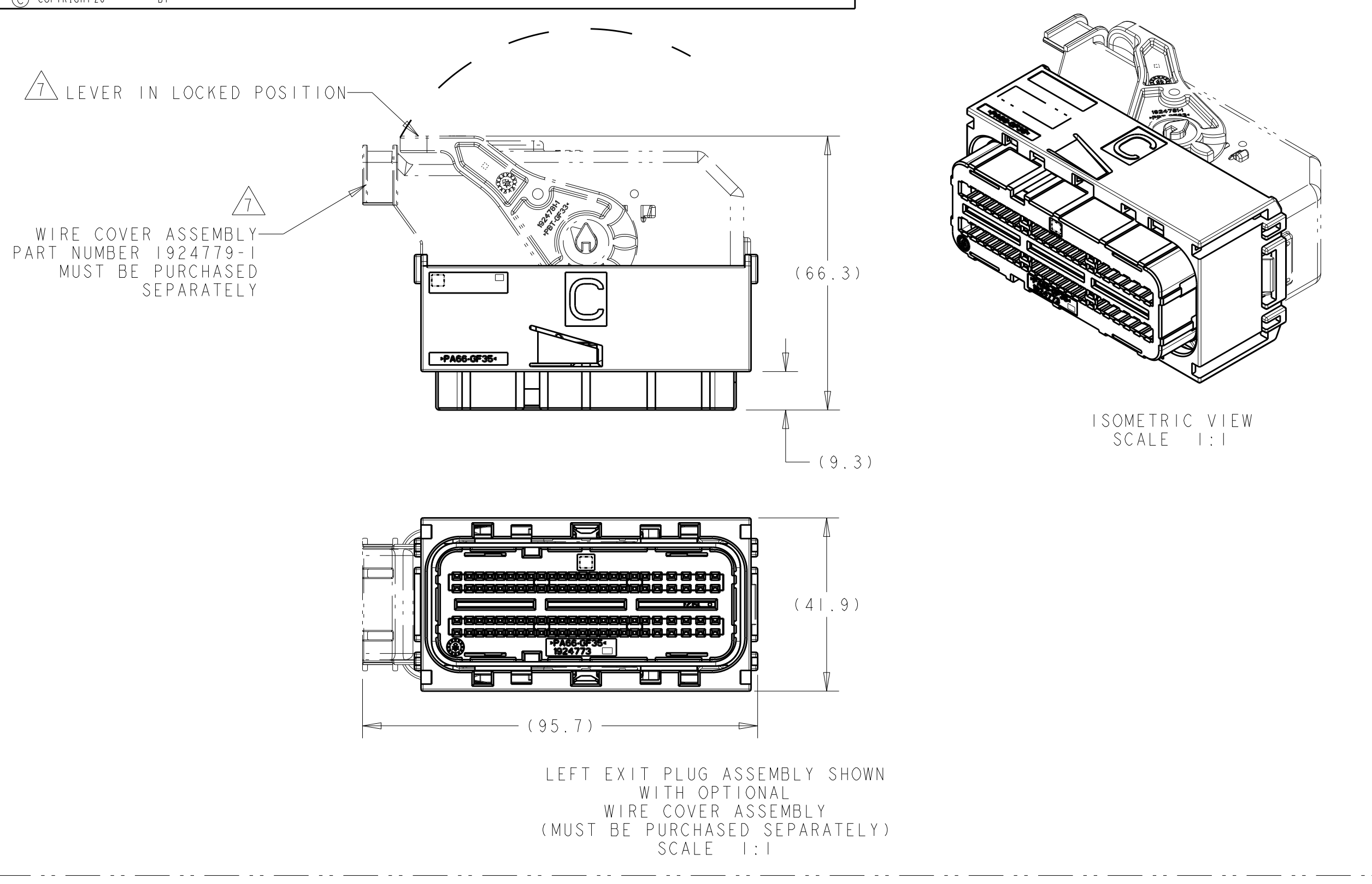
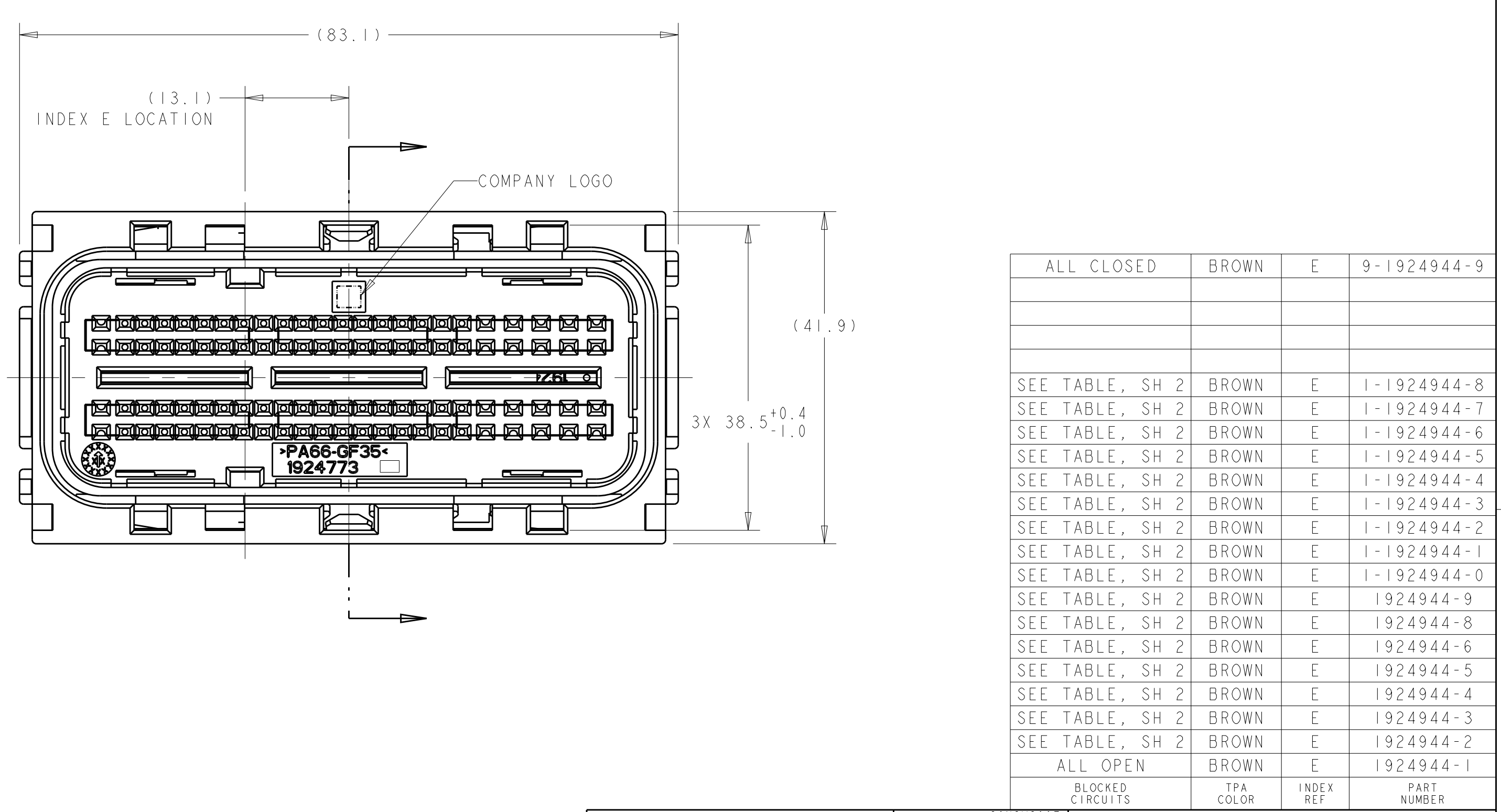
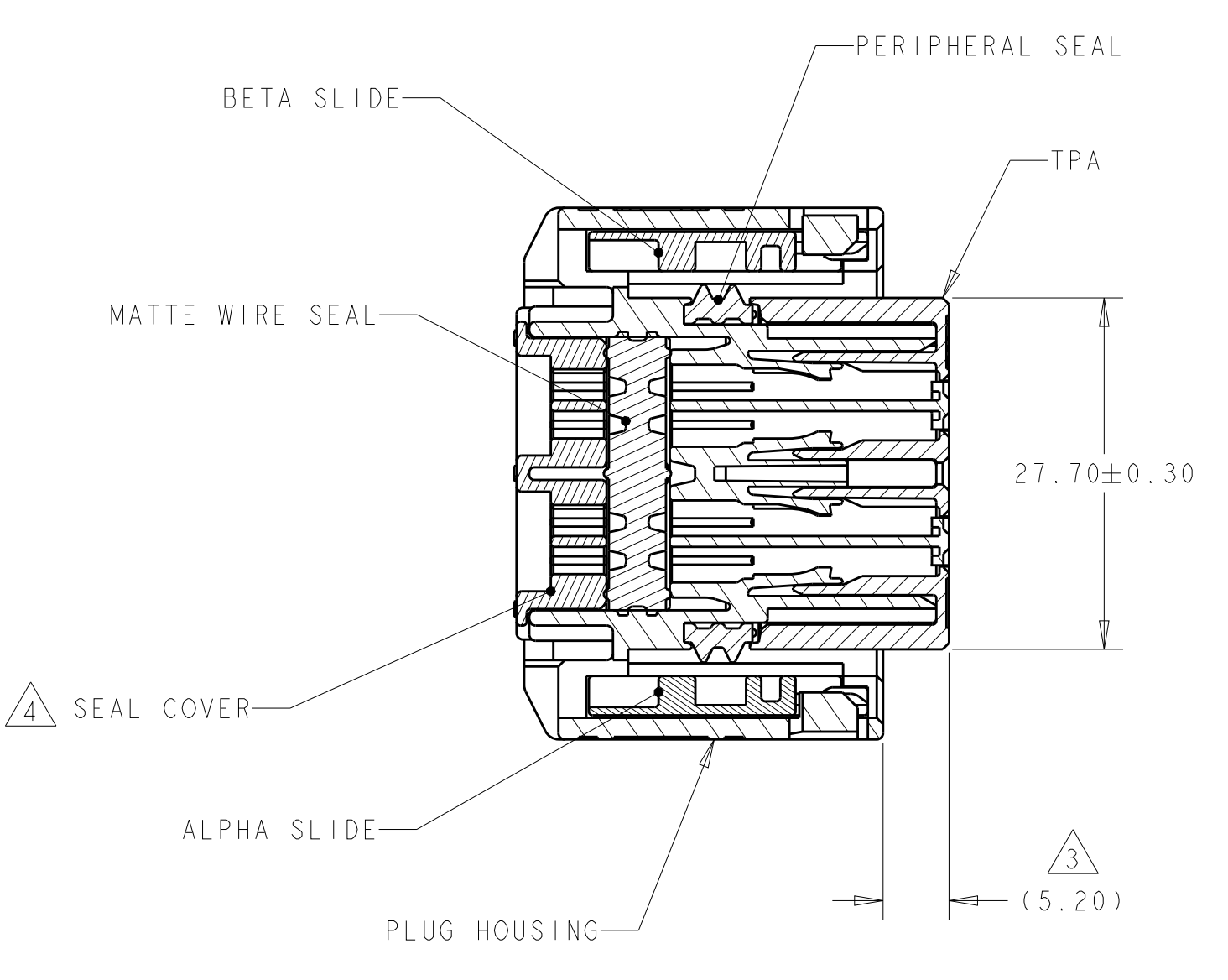

ALL CLOSED	BROWN	E	9-1924944-9
SEE TABLE, SH 2	BROWN	E	1-1924944-8
SEE TABLE, SH 2	BROWN	E	1-1924944-7
SEE TABLE, SH 2	BROWN	E	1-1924944-6
SEE TABLE, SH 2	BROWN	E	1-1924944-5
SEE TABLE, SH 2	BROWN	E	1-1924944-4
SEE TABLE, SH 2	BROWN	E	1-1924944-3
SEE TABLE, SH 2	BROWN	E	1-1924944-2
SEE TABLE, SH 2	BROWN	E	1-1924944-1
SEE TABLE, SH 2	BROWN	E	1-1924944-0
SEE TABLE, SH 2	BROWN	E	1924944-9
SEE TABLE, SH 2	BROWN	E	1924944-8
SEE TABLE, SH 2	BROWN	E	1924944-6
SEE TABLE, SH 2	BROWN	E	1924944-5
SEE TABLE, SH 2	BROWN	E	1924944-4
SEE TABLE, SH 2	BROWN	E	1924944-3
SEE TABLE, SH 2	BROWN	E	1924944-2
ALL OPEN	BROWN	E	1924944-1
BLOCKED CIRCUITS	TPA COLOR	INDEX REF	PART NUMBER

THIS DRAWING IS A CONTROLLED DOCUMENT.

OWN: DJ HARDY 29NOV2007
CHK: AJ VASBINDER 03DEC2007
APP'D: AJ VASBINDER 03DEC2007

TE Connectivity

PLUG ASSEMBLY, 96 POSITION, INDEX E - LEFT EXIT, SEALED, GPEC 11

SIZE: A1 00779 C=1924944 SHEET 1 OF 2 REV C1

CUSTOMER DRAWING

