

QT-Brightek Optocoupler Series

RANDOM-PHASE TRIAC OPTOCOUPLER

Part No.: Q301X/ Q302X/ Q305X series

Product: Q301X/ Q302X/ Q305X series	Date: February 19, 2014	Page 1 of 14
	Version# 1.2	

Table of Contents:

Introduction	3
Absolute Maximum Rating	6
Electrical Characteristic ($T_A=25^\circ\text{C}$).....	7
Characteristic Curves.....	8
Test Circuit for static dv/dt.....	9
Packing & Labeling	11
Revision History	14
Disclaimer	14

Introduction

Feature:

- High Isolation voltage between input and output (Viso = 5000V rms)
- Dual-in-line package
- Operating Temperature up to 100 °C
- Available in Tube or Tape and reel
- Available with standard DIP-6, Wide lead bend, and SMD lead options.
- Conventional black housing package

Schematic:

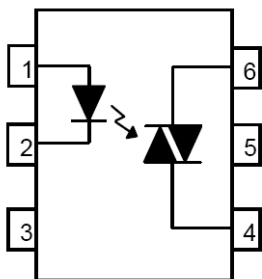

Pin Configuration

1. Anode
2. Cathode
3. No Connection
4. Terminal
5. Substrate
(do not connect)
6. Terminal

Certification & Compliance:

- Pb free and RoHS Compliant
- UL recognized (File # E338132)
- VDE recognized (File # 40030457)

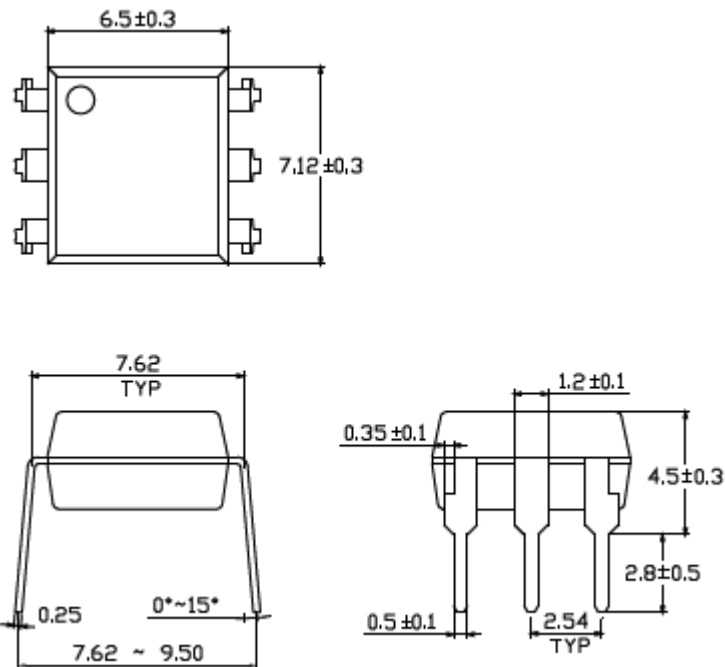
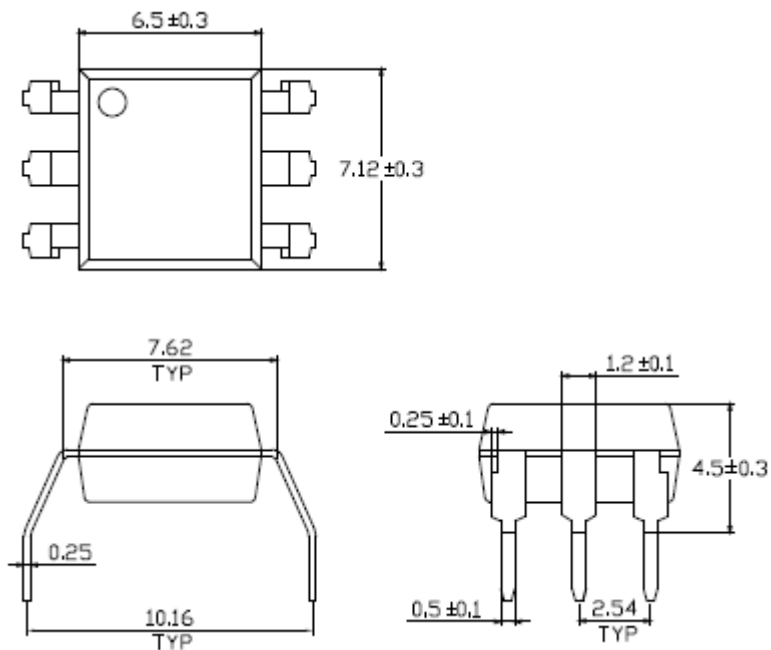

Dimension: (Dot location indicates pin 1)**6-Pin Dip (standard):****Wide lead bend (Option W):**

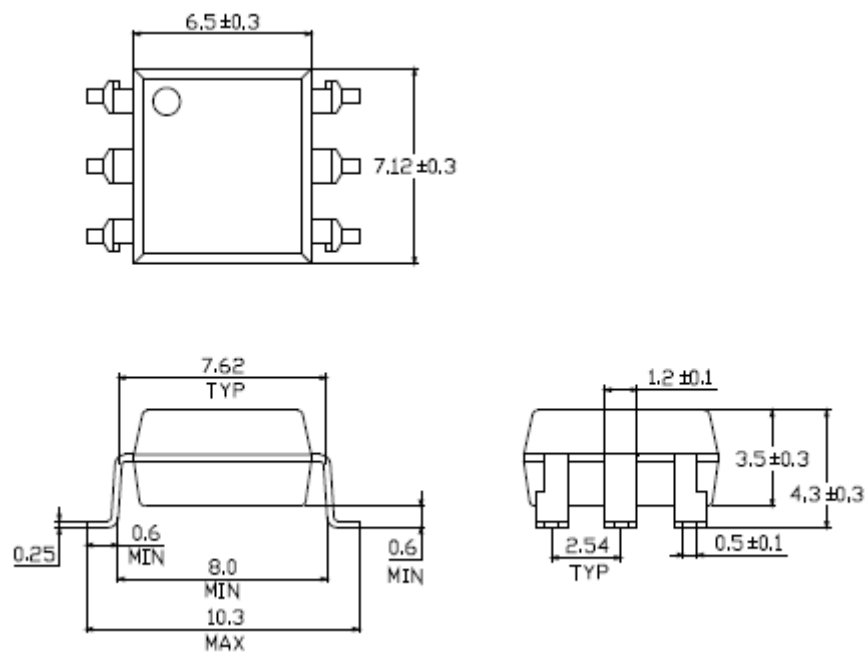
SMD lead bend (Option S):

All Dimensions are in mm
Tolerance = +/- 0.1mm

Absolute Maximum Rating

Symbol	Parameter	Rating			Units
		Q301X series	Q302X series	Q305X series	
T _{STG}	Storage Temperature	-55 ~ 150			°C
T _{OPR}	Operating Temperature	-55 ~ 100			°C
T _{SOL}	Lead Solder Temperature	260 for 10 sec			°C
P _{TOT}	Total Power Dissipation	330			mW
EMITTER					
I _F	Continuous Forward Current	60			mA
V _R	Reverse Voltage	6			V
P _D	Power Dissipation	100			mW
	Power Dissipation Derated above 25°C	1.33			mW/°C
DETECTOR					
P _D	Power Dissipation	300			mW
	Power Dissipation Derated above 25 °C	4			mW/°C
V _{DRM}	Off-state Output Terminal Voltage	Q301X series	250		V
		Q302X series	400		
		Q305X series	600		
I _{TSM}	Peak Repetitive Surge Current	1			A

Electrical Characteristic (T_A=25 °C)
Emitter

Symbol	Characteristic	Test Condition	Range			Unit
			Min	Typ	Max	
V _F	Forward Voltage	I _F = 10mA	-	1.18	1.5	V
I _R	Reverse Current	V _R = 4V	-	-	10	μA

Detector

Symbol	Characteristic	Device	Test Condition	Range			Unit
				Min	Typ	Max	
I _{DRM}	Peak Blocking Current		V _{DRM} = Rated V _{DRM} , I _F = 0mA	-	-	100	nA
V _{TM}	Peak on-state voltage		I _{TM} = 100mA peak, I _F = Rated I _{FT}	-	-	2.5	V
dv/dt	Critical Rate of Rise off-state voltage	Q301X series	V _{PEAK} = Rated V _{DRM} , I _F = 0	-	100	-	V/ μs
		Q302X series	(refer to test circuit for dv/dt)	-	100	-	
		Q305X series	V _{PEAK} = 400V, I _F = 0 (refer to test circuit for dv/dt)	1000	-	-	

Transfer Characteristic

Symbol	Characteristic	Device	Test Condition	Range			Unit
				Min	Typ	Max	
I _{FT}	LED Trigger Current	Q3010	Main terminal voltage = 3V	-	-	15	mA
		Q3021		-	-		
		Q3051		-	-		
		Q3011		-	-	10	
		Q3022		-	-		
		Q3052		-	-		
		Q3012		-	-	5	
		Q3023		-	-		
Q3053	-	-					
I _H	Holding Current			-	250	-	μA
V _{ISO}	Isolation voltage			5000	-	-	V

Characteristic Curves

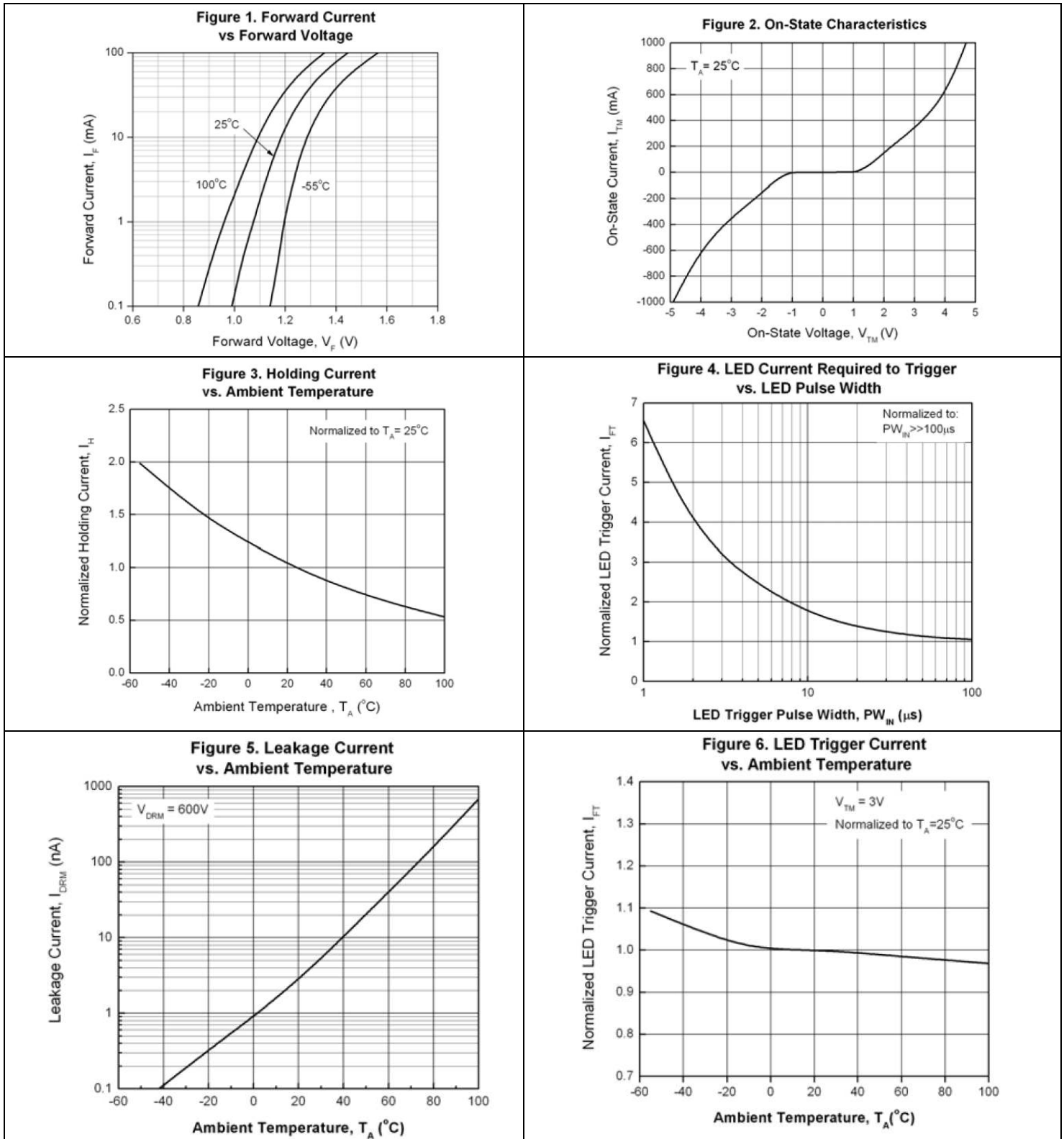

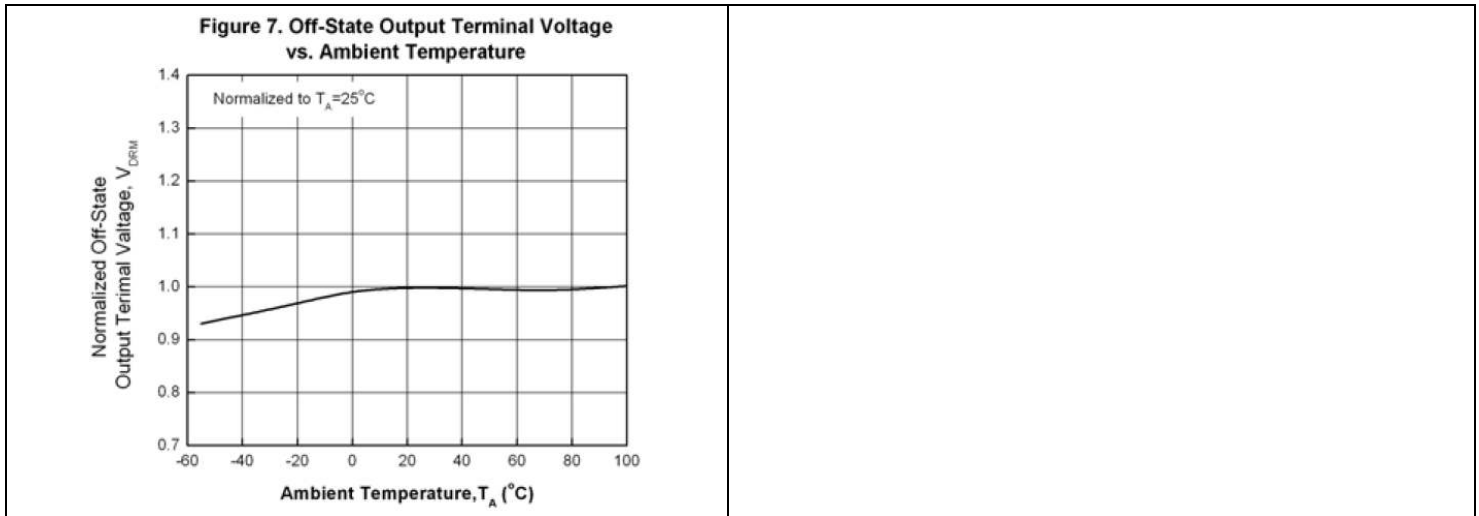

Test Circuit for static dv/dt

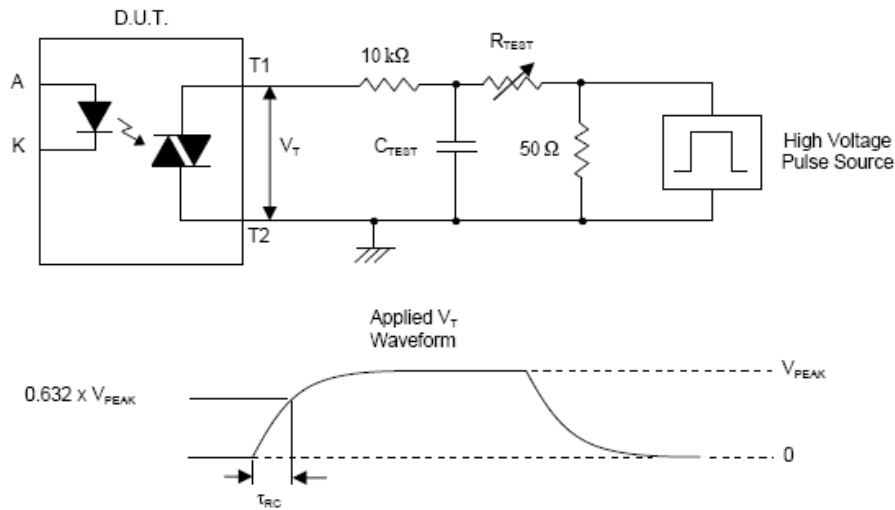

The high voltage pulse is set to the required V_{PEAK} value and applied to the D.U.T. output side through the RC circuit above. LED current is not applied. The waveform V_T is monitored using a x100 scope probe. By varying R_{TEST} , the dv/dt (slope) is increased, until the D.U.T. is observed to trigger (waveform collapses). The dv/dt is then decreased until the D.U.T. stops triggering. At this point, τ_{RC} is recorded and the dv/dt calculated.

$$dv/dt = \frac{0.632 \times V_{PEAK}}{\tau_{RC}}$$

Solder Profile & Footprint

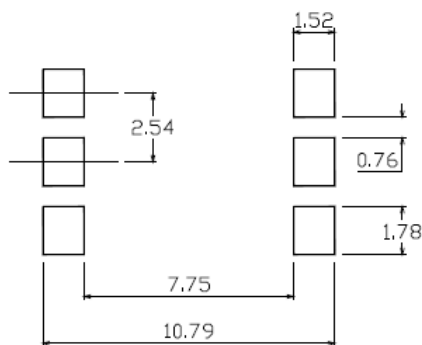
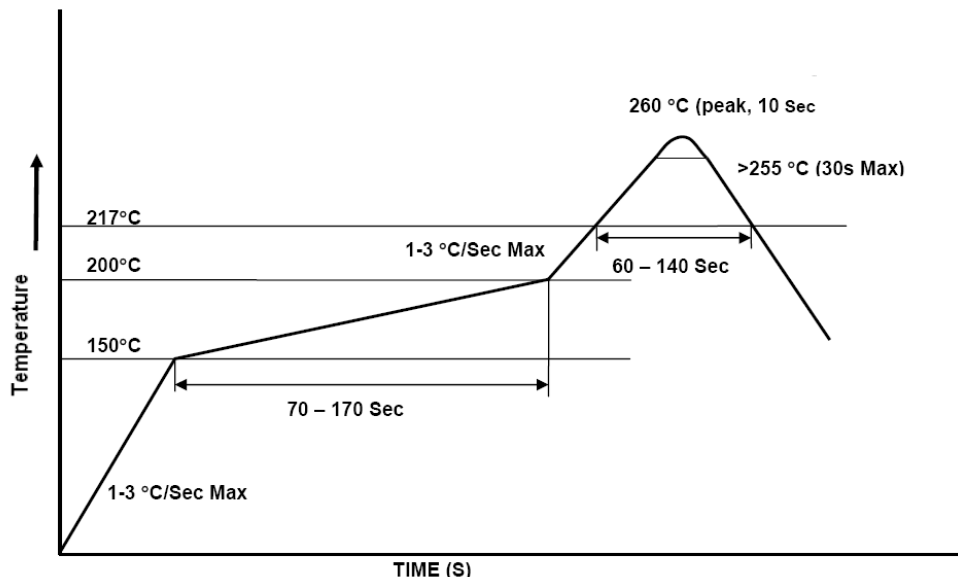

Recommended Solder Footprint for SMD Leadform

Units: mm

tolerance: +/- 0.1mm

Packing & Labeling

Tape Dimension:

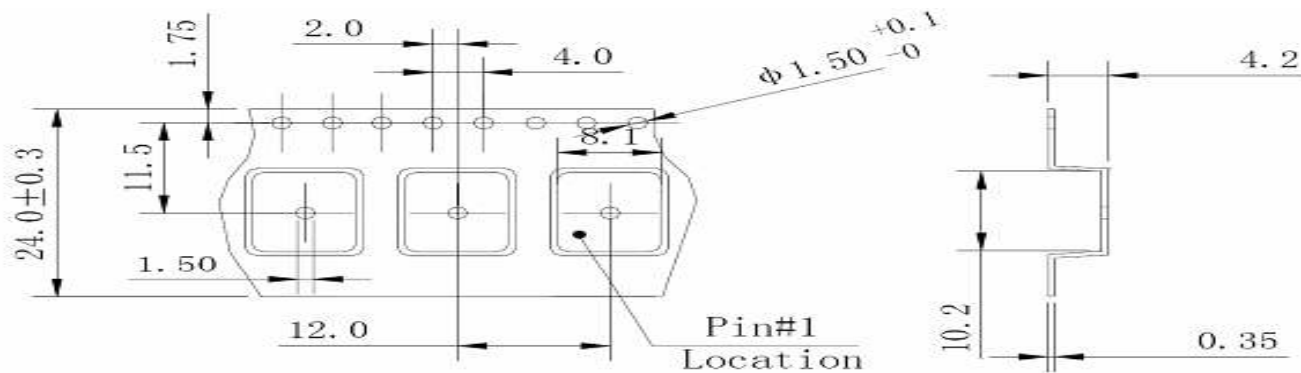

Unit: mm

Reel Dimension:

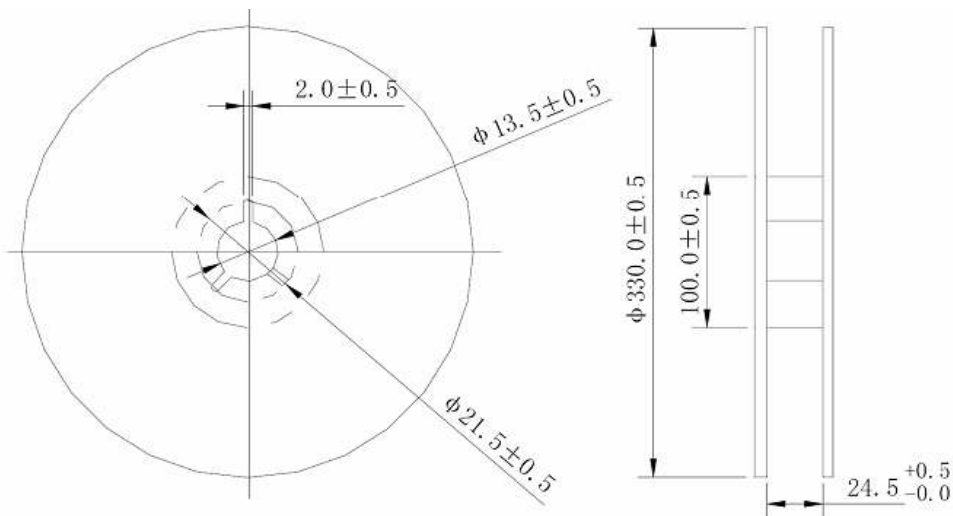

Unit: mm

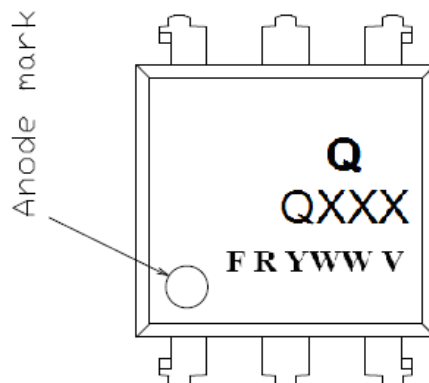
Device Marking:

Q = QT-Brightek Corporation
QXXX = Device Part Number
F = Country of Origin
R = Binning Option
Y = Year
WW = Week
V = VDE Option

Product: Q301X/ Q302X/ Q305X series	Date: February 19, 2014	Page 12 of 14
	Version# 1.2	

Ordering Information

Part Number	Orderable Part Number	Options	Description	Quantity per packing
Q301X series	Q3010 / Q3011 / Q3012	None	Standard 6pin DIP	60pcs / Tube
	Q3010V / Q3011V / Q3012V	None	Standard 6 pin Dip + With VDE marking	60pcs / Tube
	Q3010W / Q3011W / Q3012W	W	Wide lead bend (0.4 inch spacing)	60pcs / Tube
	Q3010WV / Q3011WV / Q3012WV	W	Wide lead bend (0.4 inch spacing) + VDE marking	60pcs / Tube
	Q3010STA / Q3011STA / Q3012STA	S	SMD lead form with tape and reel option	1000pcs / reel
	Q3010STAV / Q3011STAV / Q3012STAV	S	SMD lead form with tape and reel option + VDE marking	1000pcs / reel
Q302X series	Q3021 / Q3022 / Q3023	None	Standard 6pin DIP	60pcs / Tube
	Q3021V / Q3022V / Q3023V	None	Standard 6 pin Dip + With VDE marking	60pcs / Tube
	Q3021W / Q3022W / Q3023W	W	Wide lead bend (0.4 inch spacing)	60pcs / Tube
	Q3021WV / Q3022WV / Q3023WV	W	Wide lead bend (0.4 inch spacing) + VDE marking	60pcs / Tube
	Q3021STA / Q3022STA / Q3023STA	S	SMD lead form with tape and reel option	1000pcs / reel
	Q3021STAV / Q3022STAV / Q3023STAV	S	SMD lead form with tape and reel option + VDE marking	1000pcs / reel
Q305X series	Q3051 / Q3052 / Q3053	None	Standard 6pin DIP	60pcs / Tube
	Q3051V / Q3052V / Q3053V	None	Standard 6 pin Dip + With VDE marking	60pcs / Tube
	Q3051W / Q3052W / Q3053W	W	Wide lead bend (0.4 inch spacing)	60pcs / Tube
	Q3051WV / Q3052WV / Q3053WV	W	Wide lead bend (0.4 inch spacing) + VDE marking	60pcs / Tube
	Q3051STA / Q3052STA / Q3053STA	S	SMD lead form with tape and reel option	1000pcs / reel
	Q3051STAV / Q3052STAV / Q3053STAV	S	SMD lead form with tape and reel option + VDE marking	1000pcs / reel

Revision History

Description:	Revision #	Revision Date
Initial of Q301X /Q302X/Q305X series	1.0	4/22/2010
Feature, Certification & Compliance, and ordering information updates	1.1	02/01/2011
Update format and packing spec	1.2	02/19/2014

Disclaimer

QT-BRIGHTTEK reserves the right to make changes without further notice to any products herein to improve reliability, function or design. QT-BRIGHTTEK does not assume any liability arising out of the application or use of any product or circuit described herein; neither does it convey any license under its patent rights, nor the rights of others.

Life Support Policy

QT-BRIGHTTEK's products are not authorized for use as critical components in life support devices or systems without the express written approval of QT-BRIGHTTEK. As used herein:

1. Life support devices or systems are devices or systems which, (a) are intended for surgical implant into the body, or (b) support or sustain life, and (c) whose failure to perform when properly used in accordance with instructions for use provided in the labeling, can be reasonably expected to result in a significant injury of the user.
2. A critical component in any component of a life support device or system whose failure to perform can be reasonably expected to cause the failure of the life support device or system, or to affect its safety or effectiveness.