



**ANATECH ELECTRONICS INC**  
RF & Microwave Filters & Products

## 250 MHz LC Bandpass Filter

**Part Number: AE250B8813**



### Electrical specifications

**Center Frequency:** 250 MHz

**Insertion Loss:** 2 dB Max

**Return Loss:** 14 dB Min

**Ripple:** 0.1 dB

**Rejection:** >45 dB @ 0-120 MHz  
>45 dB @ 520-2000 MHz

### Mechanical

**Connector Type:** BNC (F)

**Dimensions:** 2.38 x 1.0 x 1.0 inches

### Environmental

**Operating Temperature:** -55 to +85° C

**Shock:** 30 G. 11ms

**Vibration:** 10 G. 5 to 1000 Hz

### Outline Drawing:

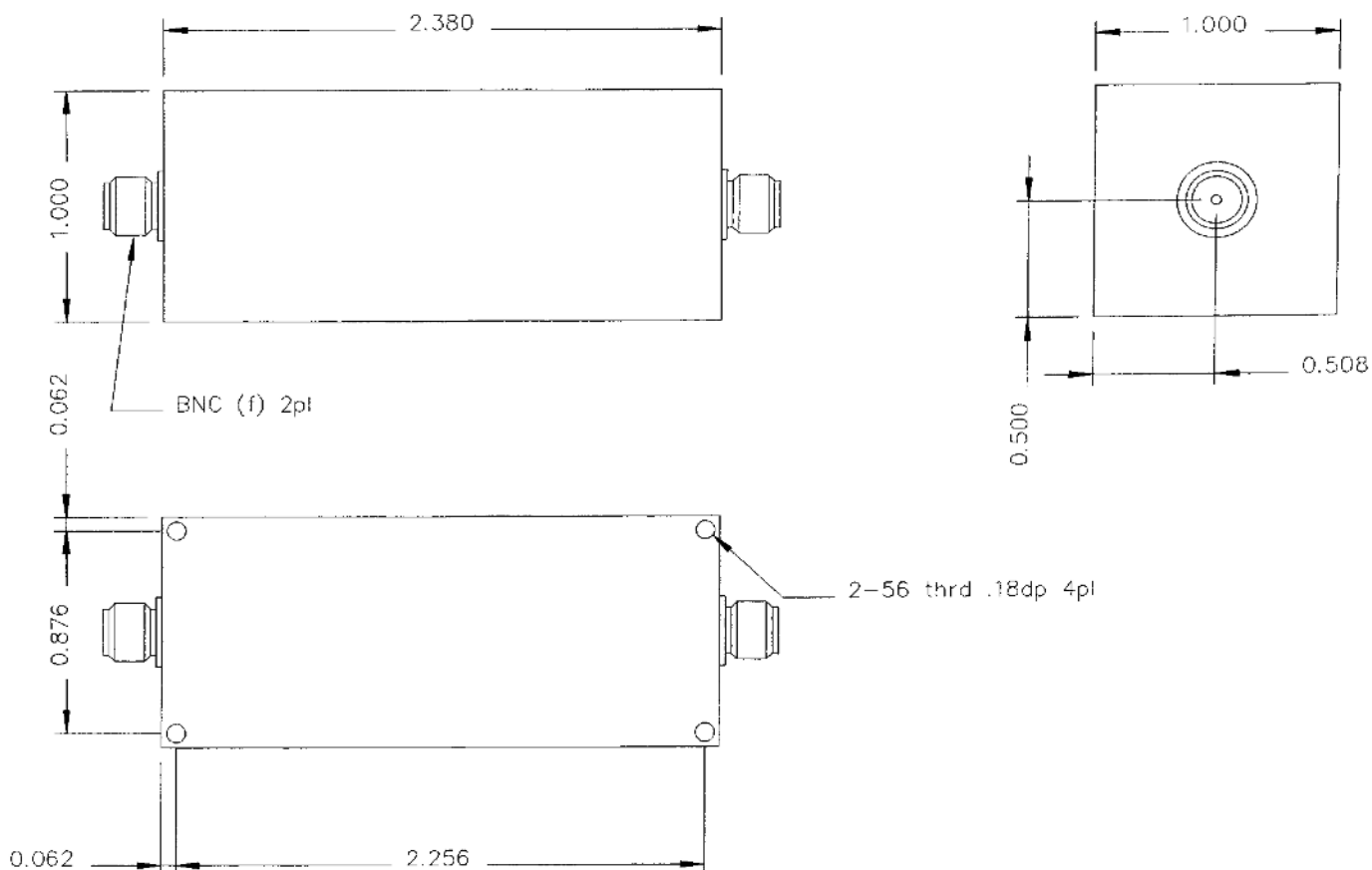



# 250 MHz LC Bandpass Filter

Part Number: AE250B8813



Plot:

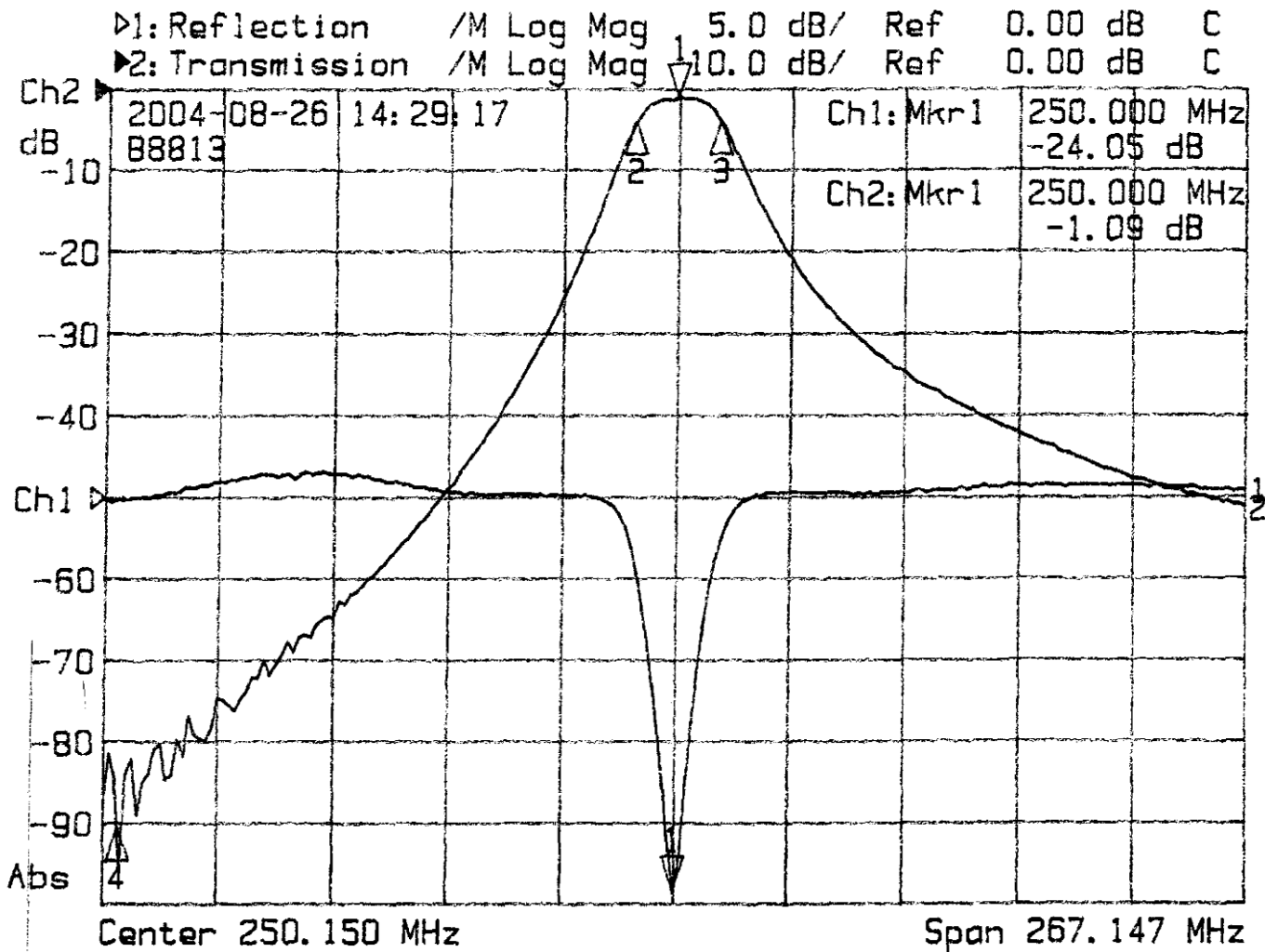

1: Mkr (MHz)	dB	2: Mkr (MHz)	dB
1> 250.00	-24.05	1> 250.00	-1.09
		2: 240.00	-4.04
		3: 260.00	-4.09
		4: 120.00	-90.73