

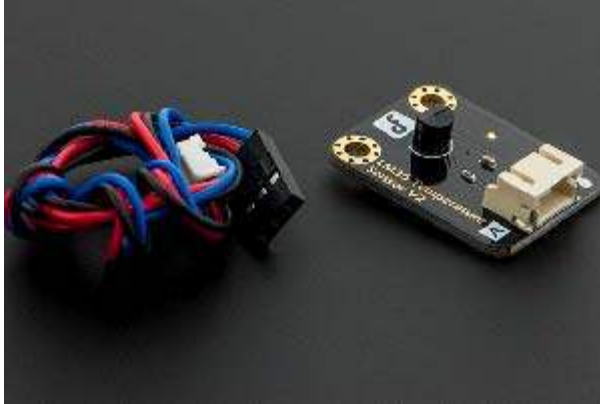

DFRobot LM35 Linear Temperature Sensor (SKU:DFR0023)



DFRobot LM35 Linear Temperature Sensor

Contents

- [1 Introduction](#)
- [2 Specification](#)
- [3 Tutorial](#)
 - [3.1 Connection Diagram](#)
 - [3.2 Sample Code 1](#)
 - [3.3 Sample Code 2](#)
- [4 Trouble shooting](#)
- [5 More](#)

Introduction

The *DFRobot LM35 Linear Temperature Sensor* is based on the semiconductor LM35 temperature sensor. The DFRobot LM35 Linear Temperature Sensor can be used to detect ambient air temperature. This sensor is produced by National Semiconductor Corporation and offers a functional range between 0 degree Celsius to 100 degree Celsius. Sensitivity is 10mV per degree Celsius. The output voltage is proportional to the temperature.

It is commonly used as a temperature measurement sensors. It includes thermocouples, platinum resistance, thermal resistance and temperature semiconductor chips, which commonly used in high temperature measurement thermocouples. Platinum resistance temperature used in the measurement of 800 degrees Celsius, while the thermal resistance and semiconductor temperature sensor suitable for measuring the temperature of 100-200 degrees or below, in which the application

of a simple semiconductor temperature sensor has good linearity and high sensitivity. The LM35 linear temperature sensor and sensor-specific expansion of Arduino board, in combination, can be very easy to achieve.

Specification

- Based on the semiconductor LM35 temperature sensor
- Can be used to detect ambient air temperature
- Sensitivity: 10mV per degree Celcius
- Functional range: 0 degree Celsius to 100 degree Celsius

Tutorial

Connection Diagram

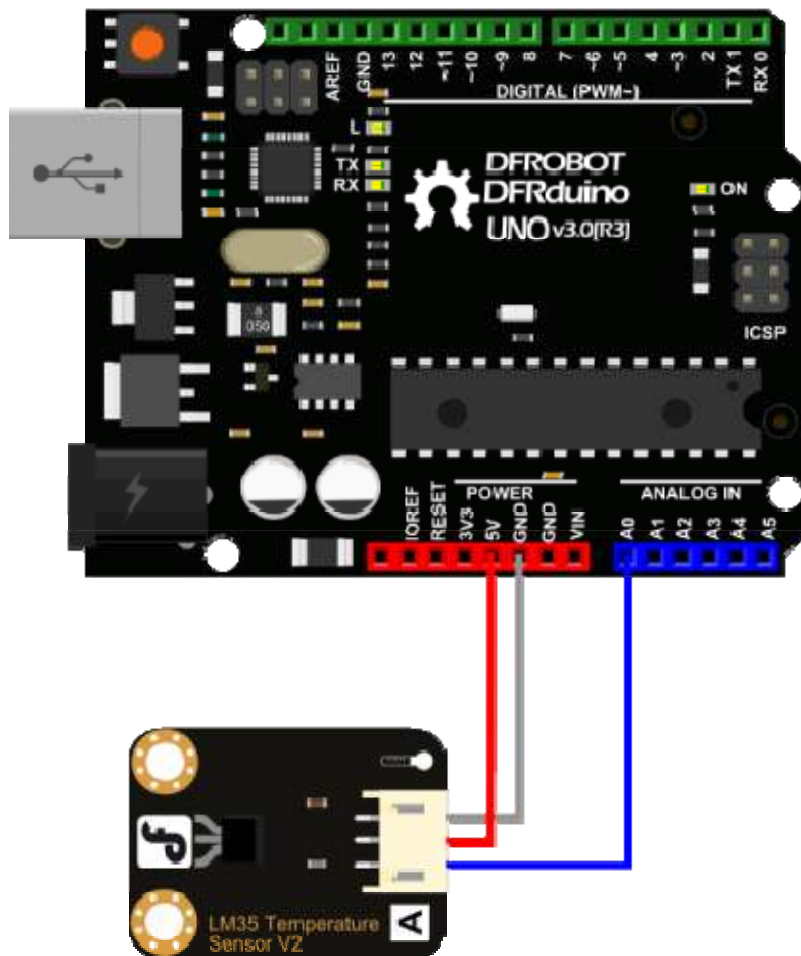

Sample Code1

Library installation

```
void setup()
{
    Serial.begin(9600); //Set Baud Rate to 9600 bps
}

void loop()
{
    int val;
    int dat;
    val=analogRead(0); //Connect LM35 on Analog 0
    dat=(500 * val) /1024;;
    Serial.print("Temp:"); //Display the temperature on Serial monitor
    Serial.print(dat);
    Serial.println("C");
    delay(500);
}
```

Sample Code 2

```
float tempC;
int reading;
int tempPin = 0;
void setup()
{
    Serial.begin(9600);
    analogReference (INTERNAL);
}
void loop()
{
    reading = analogRead(tempPin);
    tempC = reading / 9.31;
```

```
Serial.print("Temp:"); //Display the temperature on Serial monitor
Serial.print(tempC);
Serial.println("C");
delay(500);
}
```

Trouble shooting

More question and cool idea, [visit DFRobot Forum](#)