

ORDER NO.	WOODHEAD NO.	COLOR
130155-0110	67W47GF	YELLOW

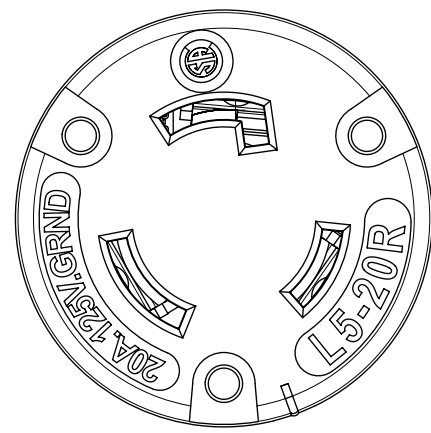

FACE VIEW

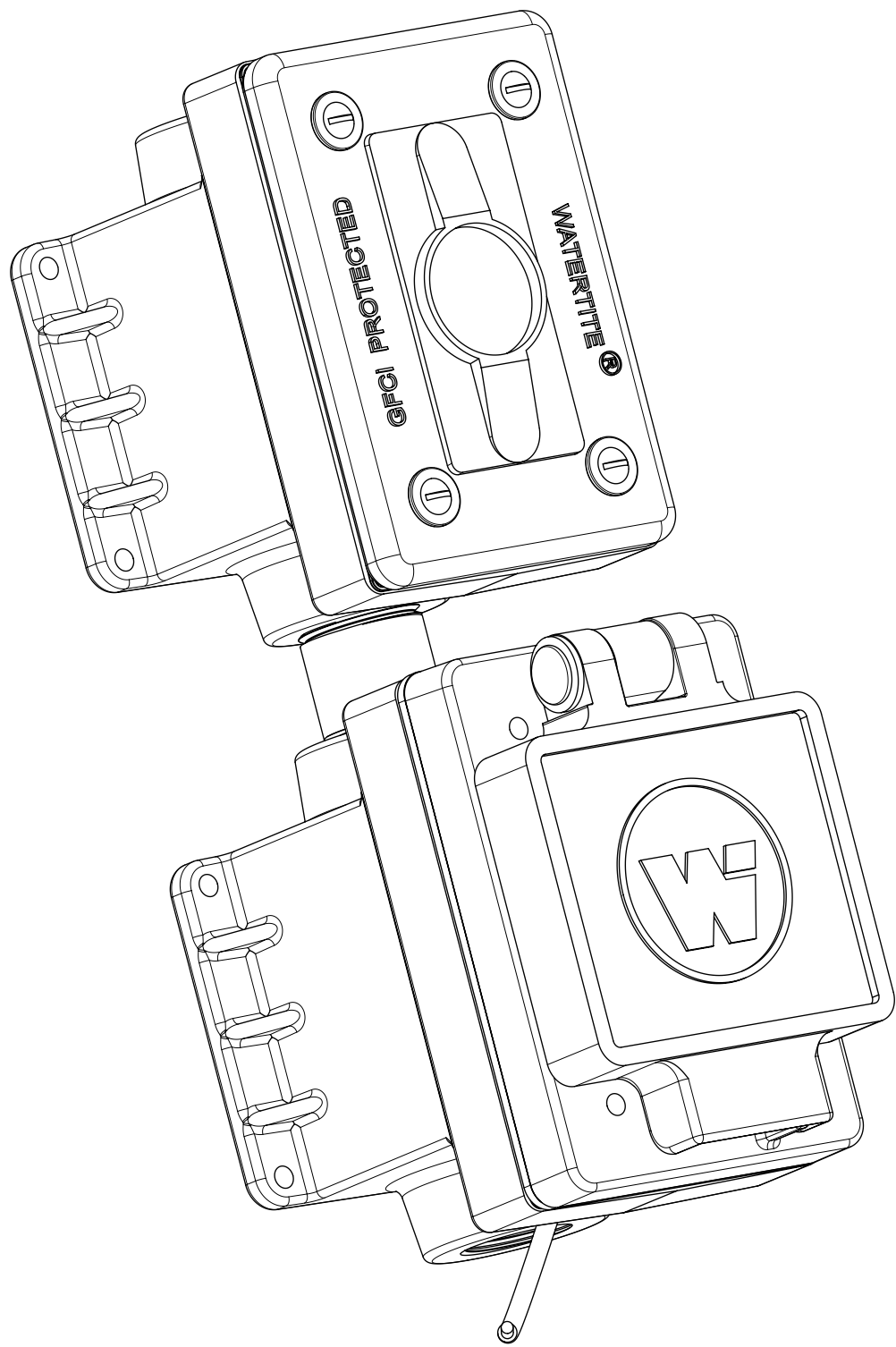
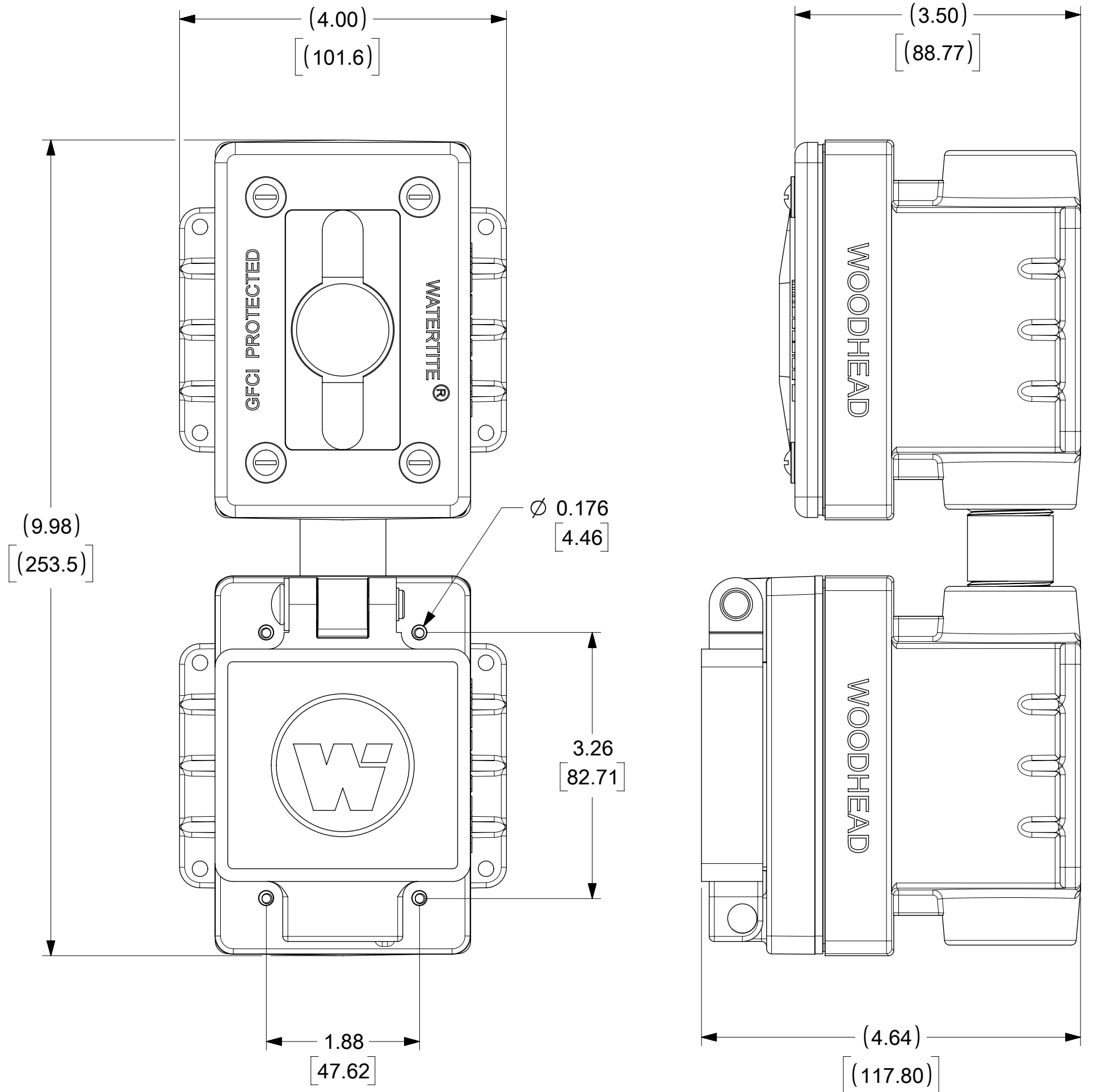

DESCRIPTION	MATERIAL	QTY.
COVER ASSEMBLY	POLYCARBONATE, STAINLESS STEEL, ALUMINUM	1
SUPPORT PLATE	STAINLESS STEEL	1
GASKET FLIP	NEOPRENE	1
FEMALE INSERT ASSY	NYLON, BRASS, NICKEL & ZINC PLATED	1
RETAINING SCREWS	STAINLESS STEEL	3
MOUNTING PLATE FD BOX	STAINLESS STEEL	4
FD BOX	COMPOSITE, UNSATURATED POLYCARBONATE	2
GFCI DEVICE 20A	POLYCARBONATE, THERMOPLASTIC, PLATED STEEL, BRASS.	1
PHILLIPS SCREW	STAINLESS STEEL	8
GFCI COVER PLATE	SILICONE	1
SCREW PAN HEAD	STAINLESS STEEL	4
THREADED NIPPLE	CHLORINATED POLYVINYL CHLORIDE (CPVC)	1
JUMPER WIRE ASSY	COPPER, BRASS (TINNED FINISH)	1
SCREW (GROUND WIRE)	STAINLESS STEEL	1
#12-1 GREEN WIRE - 6 IN LONG	COPPER WIRE	1
#12-1 BLACK PVC WIRE	COPPER WIRE	1
#12-1 GREEN PVC WIRE	COPPER WIRE	1
#12-1 WHITE PVC WIRE	COPPER WIRE	1

SYMBOLS		THIS DRAWING CONTAINS INFORMATION THAT IS PROPRIETARY TO MOLEX ELECTRONIC TECHNOLOGIES, LLC AND SHOULD NOT BE USED WITHOUT WRITTEN PERMISSION	
∇ = 0	INCH[MM]	SCALE	NTS
∇ = 0	GENERAL TOLERANCES (UNLESS SPECIFIED)		CURRENT REV DESC: MIGRATE TO NX/ECTR
∇ = 0		MM	INCH
∇ = 0	4 PLACES	±	±
∇ = 0	3 PLACES	±	±
∇ = 0	2 PLACES	±	±
∇ = 0	1 PLACE	±	±
∇ = 0	0 PLACES	±	±
∇ = 0	ANGULAR TOL	± °	
∇ = 0	DRAFT WHERE APPLICABLE MUST REMAIN WITHIN DIMENSIONS		THIRD ANGLE PROJECTION
EC NO: 613663		DRWN: SRPATIL	2019/01/17
DRWN: SRPATIL		CHK'D: DNGUYEN62	2019/03/18
APPR: HKNEELAND		INITIAL REVISION:	2019/03/30
DRWN: SRPATIL		DRWN: SRPATIL	2019/01/17
APPR: HKNEELAND		APPR: HKNEELAND	2019/03/30
C-SIZE		SERIES	130155

WATERTITE FD GFCI ASSY 2P3W L5-20

PRODUCT CUSTOMER DRAWING

DOCUMENT NUMBER: 1301550110 DOC TYPE: PSD DOC PART: 000 REVISION: A

MATERIAL NUMBER: SEE TABLE CUSTOMER: GENERAL MARKET SHEET NUMBER: 1 OF 1