

# NS5S1153

## USB 2.0 High Speed and Audio Switch with Negative Swing Capability

The NS5S1153 is a DPDT switch for combined true-ground audio and USB 2.0 high speed data applications. It allows portable systems to use a single port to pass either USB data or audio signals from an external headset; headset; the 2 channels being compliant to USB 2.0, USB 1.1 and USB 1.0.

The switch is capable of passing signals with negative voltages as low as 2 V below ground. The device features shunt resistors on the audio ports. These resistors are switched in when the audio channel is off and provide a safe path to ground for any charge that may build up on the audio lines. This reduces Pop & Click noise in the audio system. The NS5S1153 is also equipped with VBUS detection circuitry to immediately switch to USB mode in the event that a voltage is detected on VBUS.

The NS5S1153 is housed in a space saving, ultra low profile 1.4 x 1.8 x 0.5 mm 10 pin UQFN package.

### Features

- 2:1 High Speed Switch
- USB 2.0, USB 1.1 & USB 1.0 Capable on all channels
- High Bandwidth of 820 MHz on D+/D-
- Capable of Passing Negative Swing Signals Down to -2 V on R/L Channel
- 1.8 V Compatible Control Pin & VBUS Detection Circuitry for Automatic Switching
- Audio Channel Shunt Resistors for Pop & Click Noise Reduction
- Ultra-Low THD in Audio Mode: 0.01% into 16 Ω Load
- 5.25 V Tolerant Common Pins
- This is a Pb-Free Device

### Typical Applications

- Micro or Mini USB Applications
- Shared High Speed Data or Audio on a Single Connector
- Mobile Phones
- Tablets
- Bar Code Scanners
- Portable Devices

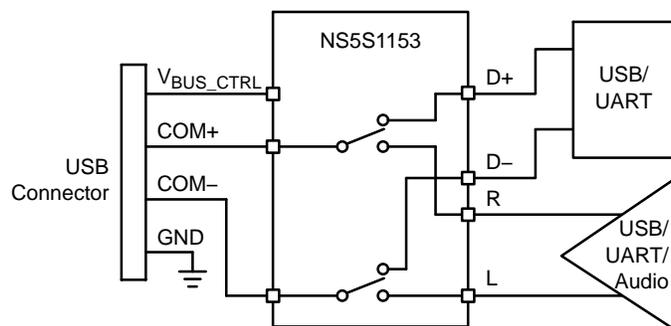

Figure 1. Application Diagram



ON Semiconductor®

[www.onsemi.com](http://www.onsemi.com)

### MARKING DIAGRAMS

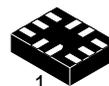

UQFN10  
CASE 488AT

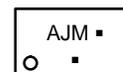

AJ = Specific Device Code  
M = Date Code  
▪ = Pb-Free Package

(Note: Microdot may be in either location)

### ORDERING INFORMATION

Device	Package	Shipping†
NS5S1153MUTAG	UQFN10 (Pb-Free)	3000 / Tape & Reel

†For information on tape and reel specifications, including part orientation and tape sizes, please refer to our Tape and Reel Packaging Specifications Brochure, BRD8011/D.

# NS5S1153

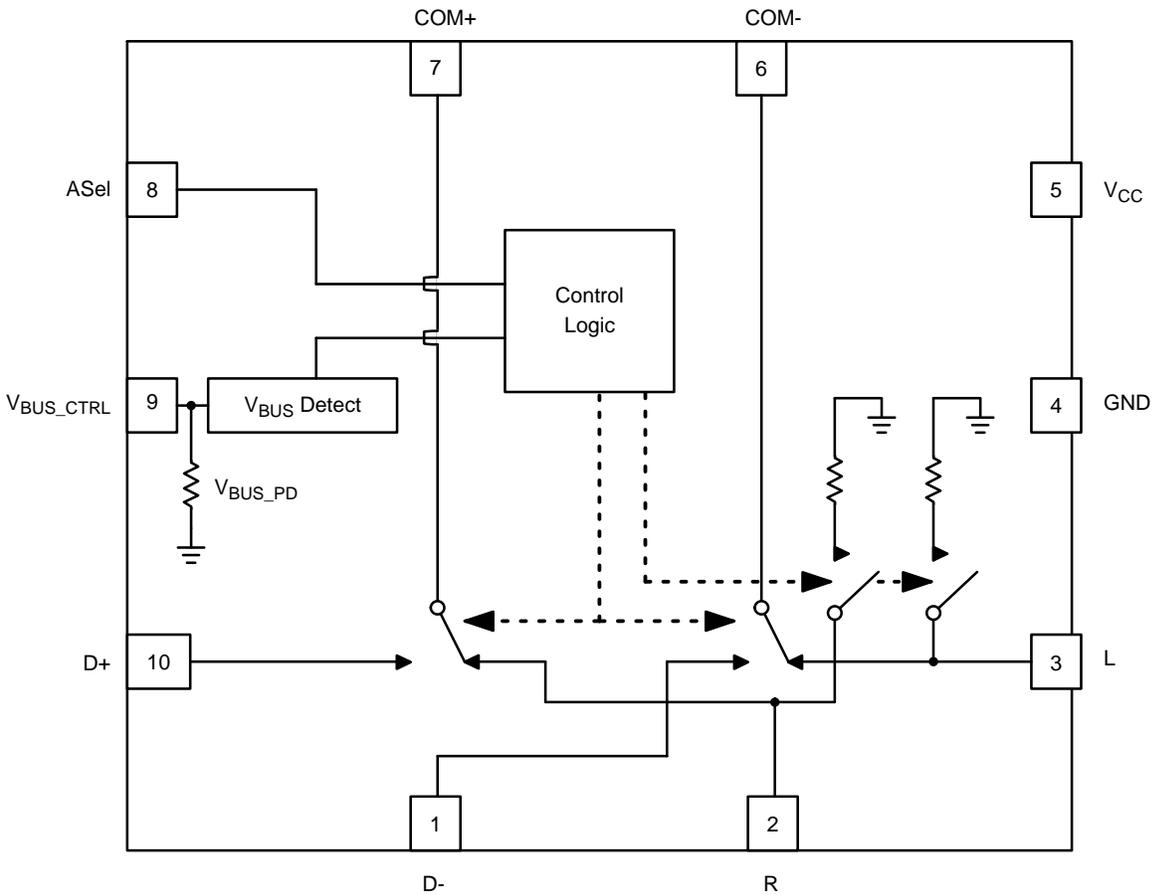

**Figure 2. Functional Block Diagram**  
(Top View)

## PIN DESCRIPTIONS

Pin #	Name	Direction	Description
1	D-	I/O	Negative Data Line for USB Signals
2	R	I/O	Right Line for Audio Signals
3	L	I/O	Left Line for Audio Signals
4	GND	Power	Ground
5	V <sub>CC</sub>	Power	Power Supply
6	COM-	I/O	Left Audio / Negative Data Common Line
7	COM+	I/O	Right Audio / Positive Data Common Line
8	A <sub>SEL</sub>	Input	Control Input Override Select Line
9	V <sub>BUS_CTRL</sub>	Input	Control Input Select Line from V <sub>BUS</sub> . If this pin is driven by an open drain I/O, we suggest maximum 100 kΩ pull up.
10	D+	I/O	Positive Data Line for USB Signals

## TRUTH TABLE

A <sub>SEL</sub>	V <sub>BUS</sub>	L, R	D+, D-	L, R SHUNT
Low	Low	ON	OFF	OFF
Low	High	OFF	ON	ON
High	X	ON	OFF	OFF

# NS5S1153

## OPERATING CONDITIONS

### MAXIMUM RATINGS

Symbol	Pins	Parameter	Value	Unit
V <sub>CC</sub>	V <sub>CC</sub>	Positive DC Supply Voltage	-0.5 to +6.0	V
V <sub>BUS</sub>	V <sub>BUS_CTRL</sub>	V <sub>BUS</sub> Control Input Voltage	-0.5 to +6.0	V
V <sub>IS</sub>	D+ to COM+ D- to COM-	Analog Signal Voltage	-0.5 to +6.0	V
	R to COM+ L to COM-		-2.5 to V <sub>CC</sub> + 0.5	
V <sub>IS</sub>	COM+, COM-	DC Signal Voltage Tolerance (<24 hours)	5.25	V
V <sub>IN</sub>	ASel	Control Input Override Voltage	-0.5 to +6.0	V
I <sub>CC</sub>	V <sub>CC</sub>	Positive DC Supply Current	50	mA
T <sub>S</sub>		Storage Temperature	-65 to +150	°C
I <sub>IS_CON</sub>	COM+, COM- R, L, D+, D-	Analog Signal Continuous Current–Closed Switch	± 100	mA
I <sub>IS_PK</sub>	COM+, COM- R, L, D+, D-	Analog Signal Continuous Current 10% Duty Cycle	± 500	mA
I <sub>IN</sub>	ASel	Control Input Override Current	1	mA
	V <sub>BUS_CTRL</sub>	V <sub>BUS</sub> Control Input Current	1	

Stresses exceeding those listed in the Maximum Ratings table may damage the device. If any of these limits are exceeded, device functionality should not be assumed, damage may occur and reliability may be affected.

### RECOMMENDED OPERATING CONDITIONS

Symbol	Pins	Parameter	Min	Max	Unit
V <sub>CC</sub>	V <sub>CC</sub>	Positive DC Supply Voltage	2.7	5.0	V
V <sub>BUS</sub>	V <sub>BUS_CTRL</sub>	V <sub>BUS</sub> Control Input Voltage	GND	5.25	V
V <sub>IS</sub>	D+ to COM+ D- to COM-	Analog Signal Voltage (Note 1)	GND	V <sub>CC</sub>	V
	R to COM+ L to COM-		-2.0	V <sub>CC</sub>	
V <sub>IN</sub>	ASel	Control Input Override Voltage	GND	V <sub>CC</sub>	V
T <sub>A</sub>		Operating Temperature	-40	+85	°C

Functional operation above the stresses listed in the Recommended Operating Ranges is not implied. Extended exposure to stresses beyond the Recommended Operating Ranges limits may affect device reliability.

1. In USB mode, any signal applied to the off-state audio inputs R, L may not swing below ground or above 1.5 V.

**DC ELECTRICAL CHARACTERISTICS**

**CONTROL INPUT** (Typical: T = 25°C, V<sub>CC</sub> = 3.3 V)

Symbol	Pins	Parameter	Test Conditions	V <sub>CC</sub> (V)	-40°C to +85°C			Unit
					Min	Typ	Max	
V <sub>IH</sub>	ASEL	Control Input HIGH Voltage		2.7 3.3 4.2	1.3 1.4 1.5	-	-	V
V <sub>IL</sub>	ASEL	Control Input LOW Voltage		2.7 3.3 4.2	-	-	0.4 0.4 0.4	V
I <sub>IN</sub>	ASEL	Current Input Leakage Current	0 ≤ V <sub>IS</sub> ≤ V <sub>CC</sub>	4.2	-	-	±50	nA
V <sub>IH</sub>	V <sub>BUS_CTRL</sub>	V <sub>BUS</sub> Control Input HIGH Voltage		2.7 3.3 4.2	1.9 2.2 2.7	-	-	V
V <sub>IL</sub>	V <sub>BUS_CTRL</sub>	V <sub>BUS</sub> Control Input LOW Voltage		2.7 3.3 4.2	-	-	0.8 1.1 1.6	V
I <sub>IN</sub>	V <sub>BUS_CTRL</sub>	V <sub>BUS</sub> Current Input Leakage Current	0 ≤ V <sub>IS</sub> ≤ V <sub>CC</sub>	4.2	-	-	±25	μA

**SUPPLY CURRENT AND LEAKAGE** (Typical: T = 25°C, V<sub>CC</sub> = 3.3 V)

Symbol	Pins	Parameter	Test Conditions	V <sub>CC</sub> (V)	-40°C to +85°C			Unit
					Min	Typ	Max	
I <sub>NC,NO(OFF)</sub>	D+, D-	OFF State Leakage	V <sub>BUS_CTRL</sub> = 0 V, 4.2 V; V <sub>COM-</sub> , V <sub>COM+</sub> = 0 V, 4.2 V V <sub>D+</sub> , V <sub>D-</sub> = 4.2 V, 0 V or float V <sub>L</sub> , V <sub>R</sub> = float or 4.2 V, 0 V	4.2			±80	nA
I <sub>COM(ON)</sub>	COM-, COM+	ON State Leakage	V <sub>BUS_CTRL</sub> = 0 V, 4.2 V; V <sub>COM-</sub> , V <sub>COM+</sub> = 0 V, 4.2 V V <sub>D+</sub> , V <sub>D-</sub> = 4.2 V, 0 V or float V <sub>L</sub> , V <sub>R</sub> = float or 4.2 V, 0 V	4.2			±100	nA
I <sub>CC</sub>	V <sub>CC</sub>	Quiescent Supply	V <sub>IS</sub> = GND to V <sub>CC</sub> ; I <sub>D</sub> = 0 A	4.2		21	35	μA
I <sub>OFF</sub>	COM-, COM+	Power OFF Leakage	0 ≤ V <sub>IS</sub> ≤ 4.2 V	0			50	μA

**USB ON RESISTANCE** (Typical: T = 25°C, V<sub>CC</sub> = 3.3 V)

Symbol	Pins	Parameter	Test Conditions	V <sub>CC</sub> (V)	-40°C to +85°C			Unit
					Min	Typ	Max	
R <sub>ON</sub>	D+ to COM+ D- to COM-	On-Resistance	I <sub>ON</sub> = 10 mA V <sub>IS</sub> = 0 V to V <sub>CC</sub>	2.7 3.3 4.2		3.0 3.0 3.0	5.5 4.6 4.6	Ω
R <sub>FLAT</sub>	D+ to COM+ D- to COM-	On-Resistance Flatness	I <sub>ON</sub> = 10 mA V <sub>IS</sub> = 0 V to V <sub>CC</sub>	2.7 3.3 4.2		0.08 0.08 0.08		Ω
ΔR <sub>ON</sub>	D+ to COM+ D- to COM-	On-Resistance Matching	I <sub>ON</sub> = 10 mA V <sub>IS</sub> = 0 V to V <sub>CC</sub>	2.7 3.3 4.2		0.03 0.03 0.03		Ω

**AUDIO ON RESISTANCE** (Typical: T = 25°C, V<sub>CC</sub> = 3.3 V)

Symbol	Pins	Parameter	Test Conditions	V <sub>CC</sub> (V)	-40°C to +85°C			Unit
					Min	Typ	Max	
R <sub>ON</sub>	R to COM+ L to COM-	On-Resistance	I <sub>ON</sub> = 10 mA V <sub>IS</sub> = -1.5 to 1.5	2.7 3.3 4.2		3.0 3.0 3.0	4.6 4.6 4.6	Ω
R <sub>FLAT</sub>	R to COM+ L to COM-	On-Resistance Flatness	I <sub>ON</sub> = 10 mA V <sub>IS</sub> = -1.5 to 1.5	2.7 3.3 4.2		0.11 0.11 0.11		Ω
ΔR <sub>ON</sub>	R to COM+ L to COM-	On-Resistance Matching	I <sub>ON</sub> = 10 mA V <sub>IS</sub> = -0.85 to 0.85	2.7 3.3 4.2		0.03 0.03 0.03		Ω
R <sub>SH</sub>	L, R	Shunt Resistance (Resistor + Switch)	I <sub>ON</sub> = 10 mA	2.7		118	160	Ω
V <sub>BUS_PD</sub>	V <sub>BUS_CTRL</sub>	V <sub>BUS_CTRL</sub> Pull-down Resistor	I <sub>ON</sub> = 10 mA			530		kΩ

# NS5S1153

## AC ELECTRICAL CHARACTERISTICS

**TIMING/FREQUENCY** (Typical: T = 25°C, V<sub>CC</sub> = 3.3 V, R<sub>L</sub> = 50 Ω, C<sub>L</sub> = 35 pF, f = 1 MHz)

Symbol	Pins	Parameter	Test Conditions	V <sub>CC</sub> (V)	-40°C to +85°C			Unit
					Min	Typ	Max	
t <sub>ON</sub>		Turn-ON Time (Closed to Open) (Figures 8 and 9)		2.7 – 4.2	–	14	–	μs
t <sub>OFF</sub>		Turn-OFF Time (Closed to Open) (Figures 8 and 9)		2.7 – 4.2	–	75	–	ns
T <sub>BBM</sub>		Break-Before-Make Time (Figure 7)			–	7.0	–	μs
BW	D+ to COM+ D- to COM-	-3 dB Bandwidth (Figure 10)	C <sub>L</sub> = 5 pF R <sub>S</sub> = 50 Ω		–	900	–	MHz

**ISOLATION** (Typical: T = 25°C, V<sub>CC</sub> = 3.3 V, R<sub>L</sub> = 50 Ω, C<sub>L</sub> = 5 pF)

Symbol	Pins	Parameter	Test Conditions	V <sub>CC</sub> (V)	-40°C to +85°C			Unit
					Min	Typ	Max	
O <sub>IRR</sub>	Open	OFF-Isolation (Figure 10)	f = 100 kHz, R <sub>S</sub> = 50 Ω		–	-81	–	dB
X <sub>TALK</sub>	COM+ to COM-	Non-Adjacent Channel Crosstalk (Figure 10)	f = 100 kHz, R <sub>S</sub> = 50 Ω		–	-93	–	dB
THD+N		Total Harmonic Distortion + Noise	V <sub>BUS_CTRL</sub> = 0 V A <sub>SEL</sub> = 3.0 V f = 20 Hz to 20 kHz V <sub>COM</sub> = 0.5 V <sub>pp</sub> R <sub>L</sub> = 600 Ω	3.0	–	0.001	–	%
THD		Total Harmonic Distortion	V <sub>BUS_CTRL</sub> = 0 V A <sub>SEL</sub> = 0 V, 3.6 V f = 1 kHz V <sub>COM</sub> = ±2.0 V <sub>pp</sub> R <sub>L</sub> = 16 Ω	3.6	–	0.01	–	%
PSRR		Power Supply Rejection Ratio	f = 10 kHz R <sub>COM</sub> = 50 Ω	3.0	–	60	–	dB

**CAPACITANCE** (Typical: T = 25°C, V<sub>CC</sub> = 3.3 V, R<sub>L</sub> = 50 Ω, C<sub>L</sub> = 5 pF, f = 1 MHz, A<sub>SEL</sub> = 0 V)

Symbol	Pins	Parameter	Test Conditions	-40°C to +85°C			Unit
				Min	Typ	Max	
C <sub>IN</sub>	A <sub>SEL</sub>	Control Pin Input Capacitance	V <sub>CC</sub> = 0 V	–	2.6	–	pF
C <sub>ON</sub>	D+ to COM+ D- to COM-	USB ON Capacitance	V <sub>BUS_CTRL</sub> = 5 V	–	6.9	–	pF
C <sub>ON</sub>	R to COM+ L to COM-	Audio ON Capacitance	V <sub>BUS_CTRL</sub> = 0 V	–	9.3	–	pF
C <sub>OFF</sub>	D+, D-	USB OFF Capacitance	V <sub>BUS_CTRL</sub> = 0 V	–	4.8	–	pF
C <sub>OFF</sub>	R, L	Audio OFF Capacitance	V <sub>BUS_CTRL</sub> = 5 V	–	4.8	–	pF

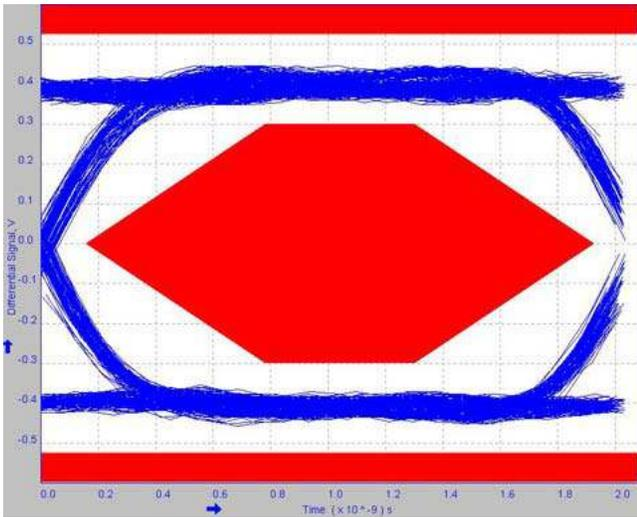

Figure 3. High Speed USB Eye Diagram of Signal Path without Switch

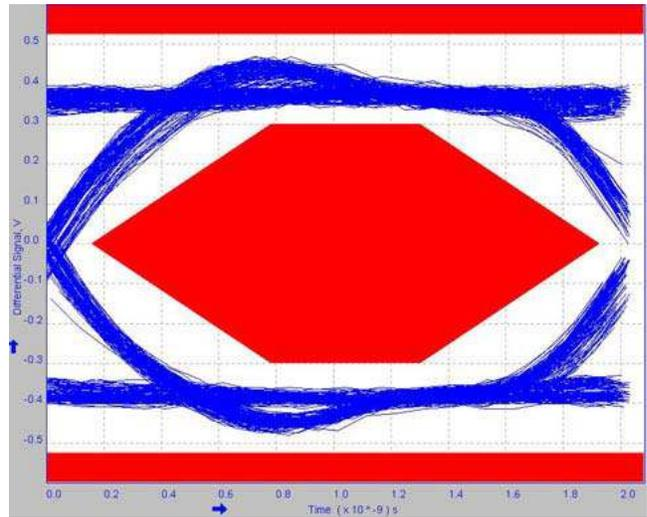

Figure 4. High Speed USB Eye Diagram of Signal Path with NS5S1153 ( $V_{CC} = 3.6 V$ )

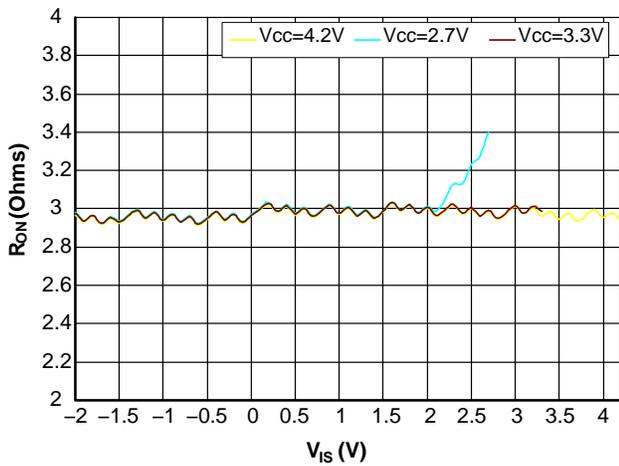

Figure 5. Audio ON Resistance vs. Signal Voltage @  $T = 25^{\circ}C$ ,  $2.7 V \leq V_{CC} \leq 4.2 V$

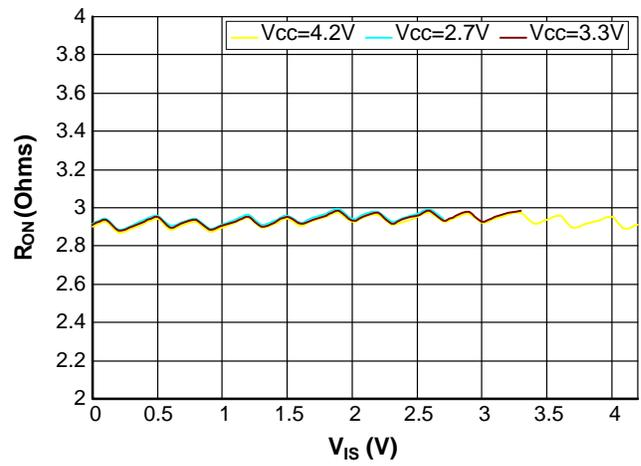

Figure 6. USB ON Resistance vs. Signal Voltage @  $T = 25^{\circ}C$ ,  $2.7 V \leq V_{CC} \leq 4.2 V$

# NS5S1153

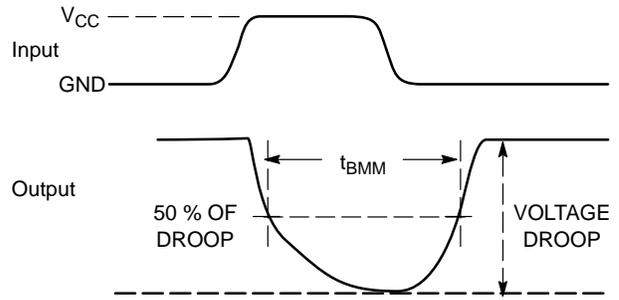
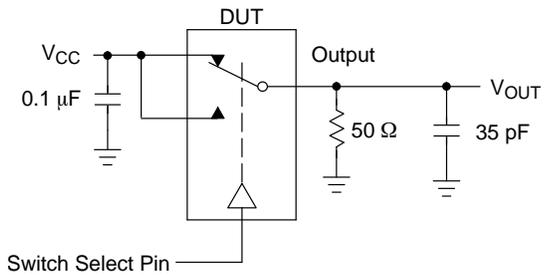

Figure 7.  $t_{BMM}$  (Time Break-Before-Make)

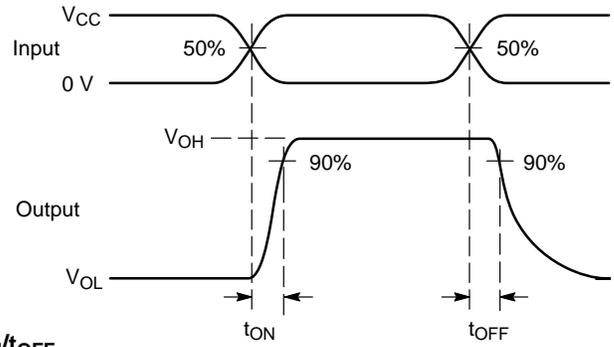
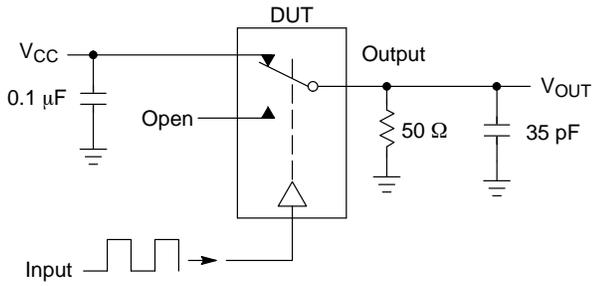

Figure 8.  $t_{ON}/t_{OFF}$

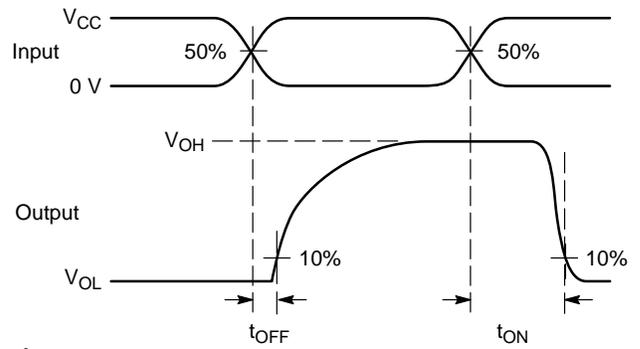
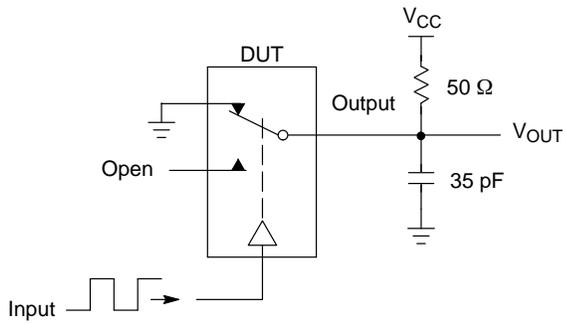
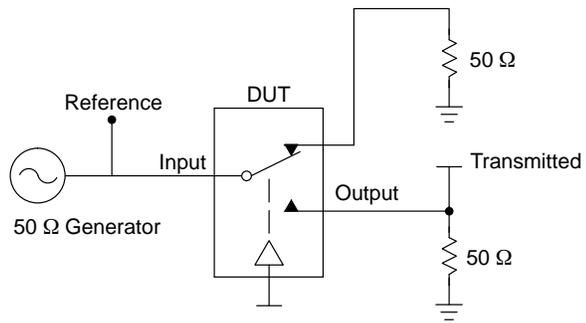

Figure 9.  $t_{ON}/t_{OFF}$

## NS5S1153



Channel switch control/s test socket is normalized. Off isolation is measured across an off channel. On loss is the bandwidth of an On switch.  $V_{ISO}$ , Bandwidth and  $V_{ONL}$  are independent of the input signal direction.

$$V_{ISO} = \text{Off Channel Isolation} = 20 \text{ Log} \left( \frac{V_{OUT}}{V_{IN}} \right) \text{ for } V_{IN} \text{ at } 100 \text{ kHz}$$

$$V_{ONL} = \text{On Channel Loss} = 20 \text{ Log} \left( \frac{V_{OUT}}{V_{IN}} \right) \text{ for } V_{IN} \text{ at } 100 \text{ kHz to } 50 \text{ MHz}$$

Bandwidth (BW) = the frequency 3 dB below  $V_{ONL}$

$V_{CT}$  = Use  $V_{ISO}$  setup and test to all other switch analog input/outputs terminated with 50  $\Omega$

**Figure 10. Off Channel Isolation/On Channel Loss (BW)/Crosstalk (On Channel to Off Channel)/ $V_{ONL}$**

# MECHANICAL CASE OUTLINE

## PACKAGE DIMENSIONS

ON Semiconductor®



### UQFN10 1.4x1.8, 0.4P CASE 488AT-01 ISSUE A

DATE 01 AUG 2007

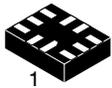

SCALE 5:1

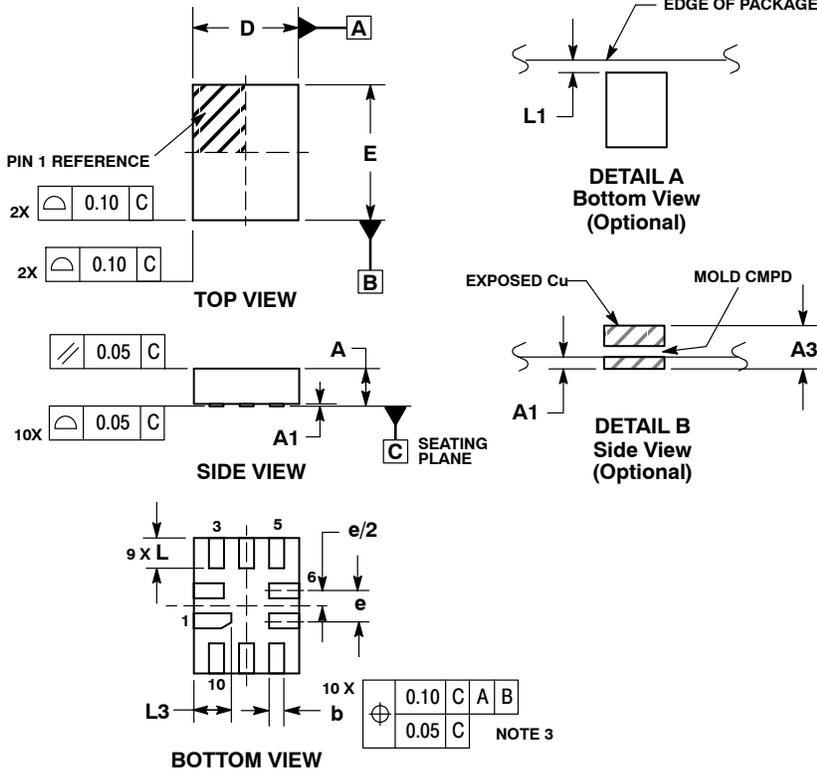

- NOTES:
1. DIMENSIONING AND TOLERANCING PER ASME Y14.5M, 1994.
  2. CONTROLLING DIMENSION: MILLIMETERS
  3. DIMENSION b APPLIES TO PLATED TERMINAL AND IS MEASURED BETWEEN 0.25 AND 0.30 MM FROM TERMINAL.
  4. COPLANARITY APPLIES TO THE EXPOSED PAD AS WELL AS THE TERMINALS.

### GENERIC MARKING DIAGRAM\*

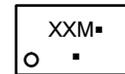

- XX = Specific Device Code
  - M = Date Code
  - = Pb-Free Package
- (Note: Microdot may be in either location)

\*This information is generic. Please refer to device data sheet for actual part marking. Pb-Free indicator, "G" or microdot "▪", may or may not be present.

### MOUNTING FOOTPRINT

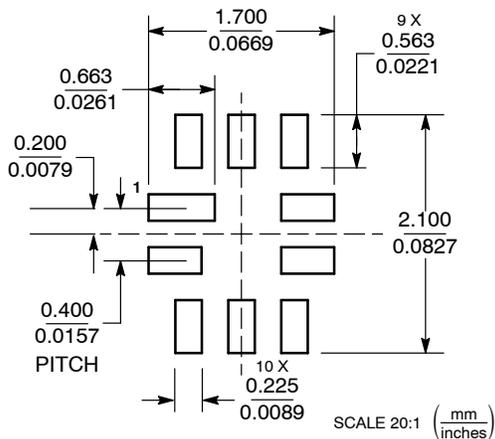

<b>DOCUMENT NUMBER:</b>	<b>98AON22493D</b>	Electronic versions are uncontrolled except when accessed directly from the Document Repository. Printed versions are uncontrolled except when stamped "CONTROLLED COPY" in red.
<b>DESCRIPTION:</b>	<b>10 PIN UQFN, 1.4 X 1.8, 0.4P</b>	<b>PAGE 1 OF 1</b>

ON Semiconductor and ON are trademarks of Semiconductor Components Industries, LLC dba ON Semiconductor or its subsidiaries in the United States and/or other countries. ON Semiconductor reserves the right to make changes without further notice to any products herein. ON Semiconductor makes no warranty, representation or guarantee regarding the suitability of its products for any particular purpose, nor does ON Semiconductor assume any liability arising out of the application or use of any product or circuit, and specifically disclaims any and all liability, including without limitation special, consequential or incidental damages. ON Semiconductor does not convey any license under its patent rights nor the rights of others.

**onsemi**, **Onsemi**, and other names, marks, and brands are registered and/or common law trademarks of Semiconductor Components Industries, LLC dba "**onsemi**" or its affiliates and/or subsidiaries in the United States and/or other countries. **onsemi** owns the rights to a number of patents, trademarks, copyrights, trade secrets, and other intellectual property. A listing of **onsemi**'s product/patent coverage may be accessed at [www.onsemi.com/site/pdf/Patent-Marking.pdf](http://www.onsemi.com/site/pdf/Patent-Marking.pdf). **onsemi** reserves the right to make changes at any time to any products or information herein, without notice. The information herein is provided "as-is" and **onsemi** makes no warranty, representation or guarantee regarding the accuracy of the information, product features, availability, functionality, or suitability of its products for any particular purpose, nor does **onsemi** assume any liability arising out of the application or use of any product or circuit, and specifically disclaims any and all liability, including without limitation special, consequential or incidental damages. Buyer is responsible for its products and applications using **onsemi** products, including compliance with all laws, regulations and safety requirements or standards, regardless of any support or applications information provided by **onsemi**. "Typical" parameters which may be provided in **onsemi** data sheets and/or specifications can and do vary in different applications and actual performance may vary over time. All operating parameters, including "Typicals" must be validated for each customer application by customer's technical experts. **onsemi** does not convey any license under any of its intellectual property rights nor the rights of others. **onsemi** products are not designed, intended, or authorized for use as a critical component in life support systems or any FDA Class 3 medical devices or medical devices with a same or similar classification in a foreign jurisdiction or any devices intended for implantation in the human body. Should Buyer purchase or use **onsemi** products for any such unintended or unauthorized application, Buyer shall indemnify and hold **onsemi** and its officers, employees, subsidiaries, affiliates, and distributors harmless against all claims, costs, damages, and expenses, and reasonable attorney fees arising out of, directly or indirectly, any claim of personal injury or death associated with such unintended or unauthorized use, even if such claim alleges that **onsemi** was negligent regarding the design or manufacture of the part. **onsemi** is an Equal Opportunity/Affirmative Action Employer. This literature is subject to all applicable copyright laws and is not for resale in any manner.

---

## ADDITIONAL INFORMATION

### TECHNICAL PUBLICATIONS:

Technical Library: [www.onsemi.com/design/resources/technical-documentation](http://www.onsemi.com/design/resources/technical-documentation)  
onsemi Website: [www.onsemi.com](http://www.onsemi.com)

### ONLINE SUPPORT: [www.onsemi.com/support](http://www.onsemi.com/support)

For additional information, please contact your local Sales Representative at [www.onsemi.com/support/sales](http://www.onsemi.com/support/sales)