



STG3P2M10N60B

1 phase bridge rectifier + 3 phase inverter
IGBT - SEMITOP[®]2 module

Features

- Low on-voltage drop ($V_{CE(sat)}$)
- Low C_{RES} / C_{IES} ratio (no cross-conduction susceptibility)
- Very soft ultra fast recovery antiparallel diode
- High frequency operation up to 70 kHz
- One screw mounting
- Compact design
- Semitop[®]2 is a trademark of Semikron

Applications

- High frequency motor controls
- Motor drivers

Description

Using the latest high voltage technology based on a patented strip layout, STMicroelectronics has designed an advanced family of IGBTs, the PowerMESH[™] IGBT, with outstanding performances.

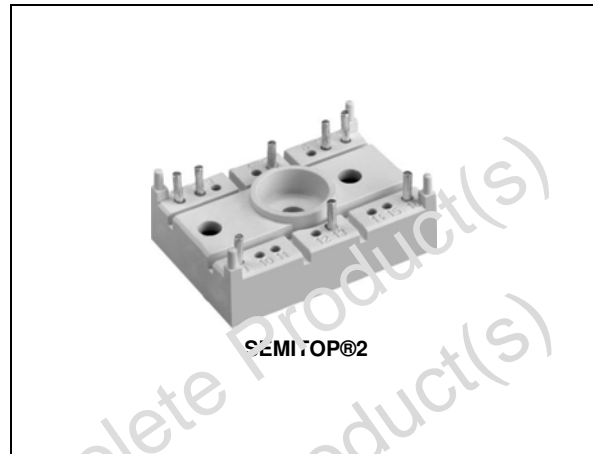

Figure 1. Internal schematic diagram

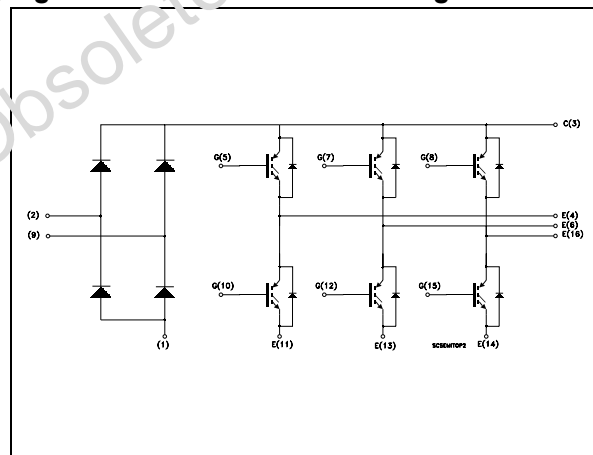

Table 1. Device summary

Order code	Marking	Package	Packaging
STG3P2M10N60B	G3P2M10N60B	SEMITOP@2	Semibox

Contents

1	Electrical ratings	3
2	Electrical characteristics	4
2.1	Typical characteristics (curves)	7
3	Test circuit	8
4	Package mechanical data	9
5	Revision history	11

Obsolete Product(s) - Obsolete Product(s)
Obsolete Product(s) - Obsolete Product(s)

1 Electrical ratings

Table 2. Absolute maximum ratings

Symbol	Parameter	Value	Unit
V_{CES}	Collector-emitter voltage ($V_{GE} = 0$)	600	V
$I_C^{(1)}$	Collector current (continuous) at $T_s = 25\text{ °C}$	19	A
$I_C^{(1)}$	Collector current (continuous) at $T_s = 80\text{ °C}$	10	A
V_{GE}	Gate-emitter voltage	± 20	V
$I_{CM}^{(2)}$	Collector current (pulsed, $t_p < 1\text{ ms}$) $T_s = 25\text{ °C}$	38	A
$I_{CM}^{(2)}$	Collector current (pulsed, $t_p < 1\text{ ms}$) $T_s = 80\text{ °C}$	20	A
I_F	Diode RMS forward current at $T_s = 25\text{ °C}$	1.5	A
P_{TOT}	Total dissipation at $T_s = 25\text{ °C}$	56	W
V_{ISO}	Insulation withstand voltage A.C. ($t = 1\text{ min/sec}$; $T_s = 25\text{ °C}$)	2500/3000	V
T_{stg}	Storage temperature	-40 to 125	°C
T_j	Operating junction temperature	-40 to 150	°C

1. Calculated value

2. Pulse width limited by max. junction temperature

Table 3. Thermal resistance

Symbol	Parameter	Value	Unit
$R_{th(j-s)}$	Thermal resistance junction-sink ⁽¹⁾ max.	2.2	k/W

1. Resistance value with conductive grease applied and maximum mounting torque equal to 2Nm

2 Electrical characteristics

($T_S = 25\text{ °C}$ unless otherwise specified)

Table 4. Static

Symbol	Parameter	Test conditions	Min.	Typ.	Max.	Unit
$V_{(BR)CES}$	Collector-emitter breakdown voltage ($V_{GE} = 0$)	$I_C = 1\text{ mA}$	600			V
I_{CES}	Collector cut-off current ($V_{GE} = 0$)	$V_{CE} = 600\text{ V}$ $V_{CE} = 600\text{ V}, T_S = 125\text{ °C}$			10 1	μA nA
I_{GES}	Gate-Emitter Leakage Current ($V_{CE} = 0$)	$V_{GE} = \pm 20\text{ V}$			± 100	nA
$V_{GE(th)}$	Gate Threshold Voltage	$V_{CE} = V_{GE}, I_C = 250\text{ }\mu\text{A}$	3.75		5.75	V
$V_{CE(sat)}$	Collector-emitter saturation voltage	$V_{GE} = 15\text{ V}, I_C = 7\text{ A}$ $V_{GE} = 15\text{ V}, I_C = 7\text{ A}, T_S = 125\text{ °C}$		1.85 1.7	2.5	V V

Table 5. Dynamic

Symbol	Parameter	Test conditions	Min.	Typ.	Max.	Unit
$g_{fs}^{(1)}$	Forward transconductance	$V_{CE} = 15\text{ V}, I_C = 7\text{ A}$		4.30		S
C_{ies}	Input capacitance	$V_{CE} = 25\text{ V}, f = 1\text{ MHz},$ $V_{GE} = 0$		720		pF
C_{oes}	Output capacitance			81		pF
C_{res}	Reverse transfer capacitance			17		pF
Q_g	Total gate charge	$V_{CE} = 390\text{ V}, I_C = 5\text{ A},$ $V_{GE} = 15\text{ V},$ (see Figure 9)		35	48	nC
Q_{ge}	Gate-emitter charge			7		nC
Q_{gc}	Gate-collector charge			16		nC

1. Pulsed: pulse duration=300 μs , duty cycle 1.5%

Table 6. Switching on/off

Symbol	Parameter	Test conditions	Min.	Typ.	Max.	Unit
$t_{d(on)}$	Turn-on delay time	$V_{CC} = 300\text{ V}, I_C = 7\text{ A}$		18.5		ns
t_r	Current rise time	$R_G = 22\ \Omega, V_{GE} = \pm 15\text{ V}$		8.5		ns
$(di/dt)_{on}$	Turn-on current slope	(see Figure 10)		1060		A/ μ s
$t_{d(on)}$	Turn-on delay time	$V_{CC} = 300\text{ V}, I_C = 7\text{ A}$		18.5		ns
t_r	Current rise time	$R_G = 22\ \Omega, V_{GE} = \pm 15\text{ V}$		7		ns
$(di/dt)_{on}$	Turn-on current slope	$T_s = 125^\circ\text{C}$ (see Figure 10)		1000		A/ μ s
$t_r(V_{off})$	Off voltage rise time	$V_{CC} = 300\text{ V}, I_C = 7\text{ A}$		27		ns
$t_{d(off)}$	Turn-off delay time	$R_G = 22\ \Omega, V_{GE} = \pm 15\text{ V}$		72		ns
t_f	Current fall time	(see Figure 10)		60		ns
$t_r(V_{off})$	Off voltage rise time	$V_{CC} = 300\text{ V}, I_C = 7\text{ A}$		56		ns
$t_{d(off)}$	Turn-off delay time	$R_G = 22\ \Omega, V_{GE} = \pm 15\text{ V}$		116		ns
t_f	Current fall time	$T_s = 125^\circ\text{C}$ (see Figure 10)		105		ns

Table 7. Switching energy (inductive load)

Symbol	Parameter	Test conditions	Min.	Typ.	Max.	Unit
$E_{on}^{(1)}$	Turn-on switching losses	$V_{CC} = 300\text{ V}, I_C = 7\text{ A}$		95		μ J
$E_{off}^{(2)}$	Turn-off switching losses	$R_G = 22\ \Omega, V_{GE} = \pm 15\text{ V}$		115		μ J
E_{ts}	Total switching losses	(see Figure 10)		210		μ J
$E_{on}^{(1)}$	Turn-on switching losses	$V_{CC} = 300\text{ V}, I_C = 7\text{ A}$		140		μ J
$E_{off}^{(2)}$	Turn-off switching losses	$R_G = 22\ \Omega, V_{GE} = \pm 15\text{ V}$		215		μ J
E_{ts}	Total switching losses	$T_s = 125^\circ\text{C}$ (see Figure 10)		355		μ J

1. E_{on} is the turn-on losses when a typical diode is used in the test circuit in figure 2. If the IGBT is offered in a package with a co-pak diode, the co-pak diode is used as external diode. IGBTs & Diode are at the same temperature (25°C and 125°C)

2. Turn-off losses include also the tail of the collector current

Table 8. Collector-emitter diode

Symbol	Parameter	Test conditions	Min.	Typ.	Max.	Unit
V_F	Forward on-voltage	$I_F = 3.5 \text{ A}$ $I_F = 3.5 \text{ A}, T_s = 125 \text{ }^\circ\text{C}$		1.3	1.9	V
				1.1		V
t_{rr}	Reverse recovery time	$I_F = 7 \text{ A}, V_R = 40 \text{ V},$ $di/dt = 100 \text{ A}/\mu\text{s}$ (see Figure 7)		37		ns
t_a				22		ns
Q_{rr}	Reverse recovery charge			40		nC
I_{rrm}	Reverse recovery current			2.1		A
S	Softness factor of the diode			0.68		
t_{rr}	Reverse recovery time		$I_F = 7 \text{ A}, V_R = 40 \text{ V},$ $di/dt = 100 \text{ A}/\mu\text{s}$ (see Figure 7)		6	
t_a				3.4		ns
Q_{rr}	Reverse recovery charge			98		nC
I_{rrm}	Reverse recovery current			3.2		A
S	Softness factor of the diode			0.79		

Table 9. Bridge rectifier diode

Symbol	Parameter	Test conditions	Min.	Typ.	Max.	Unit
V_F	Forward on-voltage	$I_F = 20 \text{ A}, T_s = 125 \text{ }^\circ\text{C}$		1.1		V
$R_{th(j-s)}$	Thermal resistance junction-sink ⁽¹⁾				2.15	K/W
T_j	Operating junction temperature		-40		150	$^\circ\text{C}$

1. Resistance value with conductive grease applied and maximum mounting torque equal to 2Nm

2.1 Typical characteristics (curves)

Figure 2. Output characteristics at $T_s = 25^\circ\text{C}$

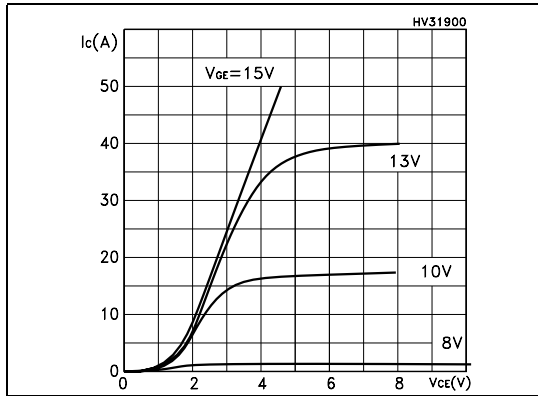

Figure 3. Output characteristics at $T_s = 125^\circ\text{C}$

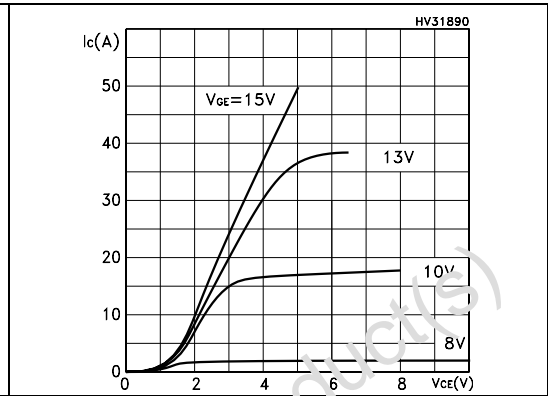

Figure 4. Capacitance variations

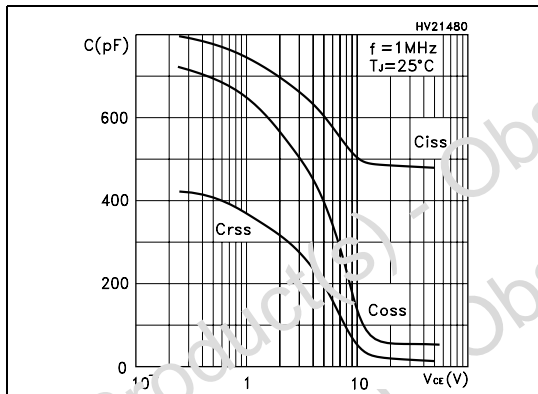

Figure 5. Gate charge vs gate-emitter voltage

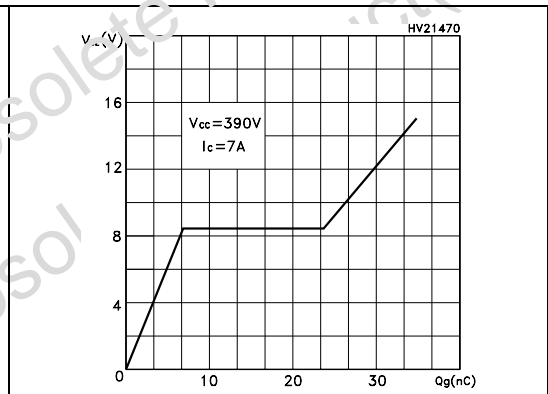

Figure 6. Total switching losses vs gate resistance

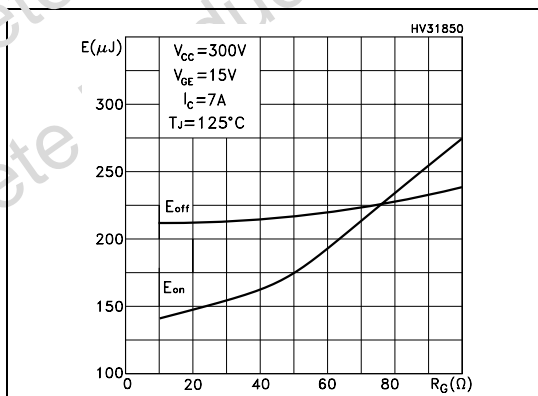
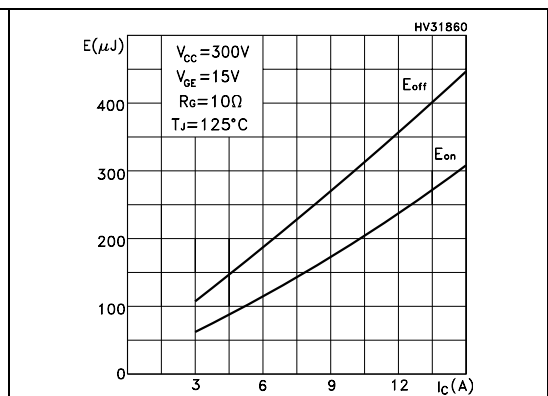

Figure 7. Total switching losses vs collector current



4 Package mechanical data

In order to meet environmental requirements, ST offers these devices in ECOPACK® packages. These packages have a Lead-free second level interconnect. The category of second level interconnect is marked on the package and on the inner box label, in compliance with JEDEC Standard JESD97. The maximum ratings related to soldering conditions are also marked on the inner box label. ECOPACK is an ST trademark. ECOPACK specifications are available at: www.st.com

Obsolete Product(s) - Obsolete Product(s)
Obsolete Product(s) - Obsolete Product(s)

SEMITOP®2 mechanical data

Dim	mm		
	Min	Typ	Max
A	15.30	15.50	15.70
A1	15.23	15.43	15.63
A2		10.50	
A3		10	
øb		1.50	
øb1		1.60	
D	40.20	40.50	40.80
D2		38	
E	27.80	28	28.20
E1	19.80	20	20.20
E2		25.50	
e	2.90	3	3.10
e1		1.50	
e2	7.80	8	8.20
e3	3.90	4	4.10
f		2.50	
L		3.50	
L1		3.50	
L2	11.80	12	12.20
L3		5.20	
øP	4.30	4.40	4.50
øP1		12	
øP2		14.50	
R		1	

SEMITOP®2 is a trademark of SEMIKRON

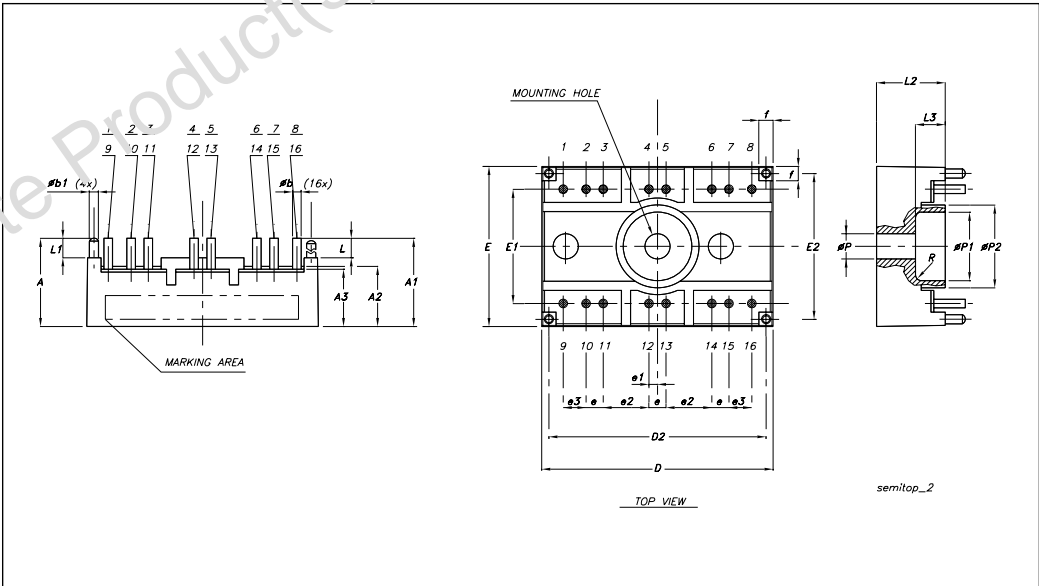

5 Revision history

Table 10. Document revision history

Date	Revision	Changes
15-May-2005	1	Initial release.
15-Oct-2008	2	Document status promoted from preliminary data to datasheet.

Obsolete Product(s) - Obsolete Product(s)
Obsolete Product(s) - Obsolete Product(s)

Please Read Carefully:

Information in this document is provided solely in connection with ST products. STMicroelectronics NV and its subsidiaries ("ST") reserve the right to make changes, corrections, modifications or improvements, to this document, and the products and services described herein at any time, without notice.

All ST products are sold pursuant to ST's terms and conditions of sale.

Purchasers are solely responsible for the choice, selection and use of the ST products and services described herein, and ST assumes no liability whatsoever relating to the choice, selection or use of the ST products and services described herein.

No license, express or implied, by estoppel or otherwise, to any intellectual property rights is granted under this document. If any part of this document refers to any third party products or services it shall not be deemed a license grant by ST for the use of such third party products or services, or any intellectual property contained therein or considered as a warranty covering the use in any manner whatsoever of such third party products or services or any intellectual property contained therein.

UNLESS OTHERWISE SET FORTH IN ST'S TERMS AND CONDITIONS OF SALE ST DISCLAIMS ANY EXPRESS OR IMPLIED WARRANTY WITH RESPECT TO THE USE AND/OR SALE OF ST PRODUCTS INCLUDING WITHOUT LIMITATION IMPLIED WARRANTIES OF MERCHANTABILITY, FITNESS FOR A PARTICULAR PURPOSE (AND THEIR EQUIVALENTS UNDER THE LAWS OF ANY JURISDICTION), OR INFRINGEMENT OF ANY PATENT, COPYRIGHT OR OTHER INTELLECTUAL PROPERTY RIGHT.

UNLESS EXPRESSLY APPROVED IN WRITING BY AN AUTHORIZED ST REPRESENTATIVE, ST PRODUCTS ARE NOT RECOMMENDED, AUTHORIZED OR WARRANTED FOR USE IN MILITARY, AIR CRAFT, SPACE, LIFE SAVING, OR LIFE SUSTAINING APPLICATIONS, NOR IN PRODUCTS OR SYSTEMS WHERE FAILURE OR MALFUNCTION MAY RESULT IN PERSONAL INJURY, DEATH, OR SEVERE PROPERTY OR ENVIRONMENTAL DAMAGE. ST PRODUCTS WHICH ARE NOT SPECIFIED AS "AUTOMOTIVE GRADE" MAY ONLY BE USED IN AUTOMOTIVE APPLICATIONS AT USER'S OWN RISK.

Resale of ST products with provisions different from the statements and/or technical features set forth in this document shall immediately void any warranty granted by ST for the ST product or service described herein and shall not create or extend in any manner whatsoever, any liability of ST.

ST and the ST logo are trademarks or registered trademarks of ST in various countries.

Information in this document supersedes and replaces all information previously supplied.

The ST logo is a registered trademark of STMicroelectronics. All other names are the property of their respective owners.

© 2008 STMicroelectronics - All rights reserved

STMicroelectronics group of companies

Australia - Belgium - Brazil - Canada - China - Czech Republic - Finland - France - Germany - Hong Kong - India - Israel - Italy - Japan - Malaysia - Malta - Morocco - Singapore - Spain - Sweden - Switzerland - United Kingdom - United States of America

www.st.com