

Board Level Heat Sinks

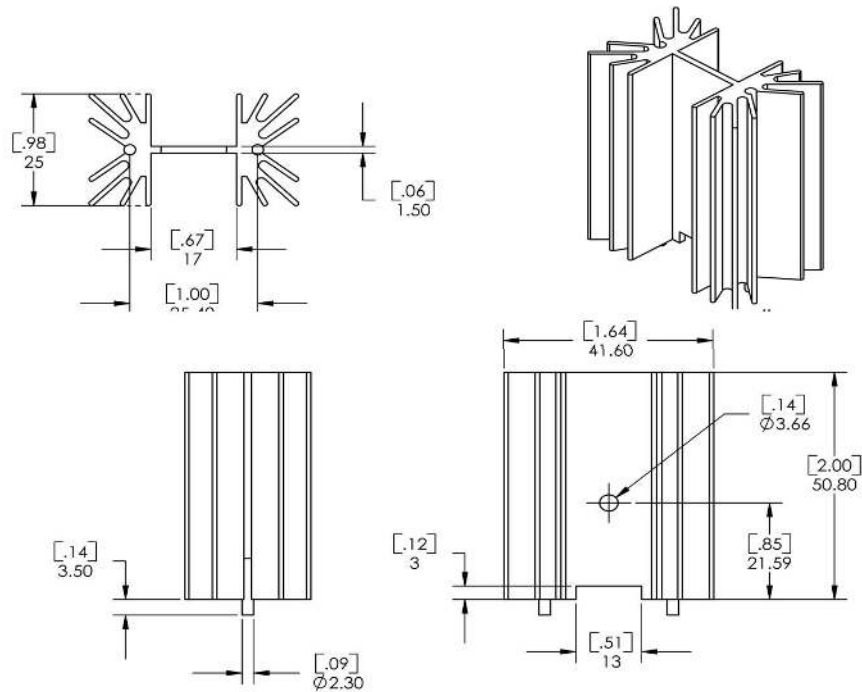

ThermaFlo

P/N: 411621B02500



PRODUCT SPECIFICATIONS

- Devices: TO-218, TO-220 & TO-247
- Size: 25.0 x 41.6 x 50.8 mm
- Material: Aluminum
- Type: Extruded
- Finish: Black Anodized
- PCB Mounting: Solderable Pins
- Package: Bulk
- Accessories: Hardware & Thermal Interface Material

FEATURES & BENEFITS

- Hole for Device Attachment
- Dual Device Cooling Heat Sink
- Vertical Mounting via Solderable Pins
- RoHS Compliant



CUSTOMIZED HEATSINKS

- Specialized Plating
- Specialized Body Configurations
- Contact Applications Engineering

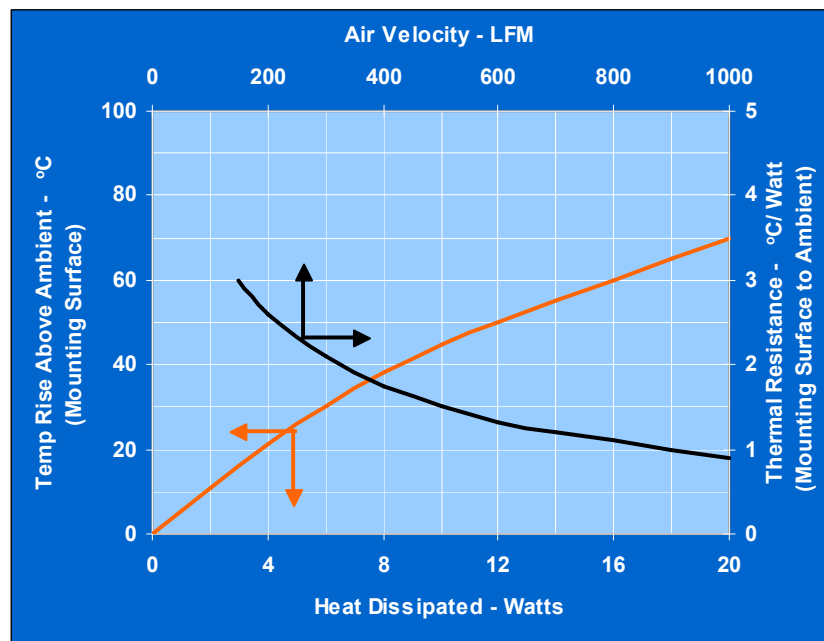

TO-218, TO-220 & TO-247

COMAIR ROTRON, INC

8929 Terman Court, San Diego, CA 92121
 Ph (858) 348-6200 Fax (858) 566-4577
 E-mail: sales@comairrotron.com,
 Web: www.comairrotron.com