

CS3341, CS3351, CS387

Alternator Voltage Regulator Darlington Driver

The CS3341/3351/387 integral alternator regulator integrated circuit provides the voltage regulation for automotive, 3-phase alternators.

It drives an external power Darlington for control of the alternator field current. In the event of a charge fault, a lamp output pin is provided to drive an external darlington transistor capable of switching on a fault indicator lamp. An overvoltage or no STATOR signal condition activates the lamp output.

The CS3341 and CS3351 are available in SOIC-14 packages. The CS387 is available as a Flip Chip.

For FET driver applications use the CS3361. Use of the CS3341, CS3351 or CS387 with external FETs may result in oscillations.

Features

- Drives NPN Darlington
- Short Circuit Protection
- 80 V Load Dump
- Temperature Compensated Regulation Voltage
- Shorted Field Protection Duty Cycle, Self Clearing
- Pb-Free Packages are Available*

MAXIMUM RATINGS

Rating	Value	Unit
Storage Temperature Range, T_S	-55 to +165	°C
Junction Temperature Range	-40 to 150	°C
Continuous Supply	27	V
I_{CC} Load Dump	400	mA
Lead Temperature Soldering: Reflow: (SMD styles only) (Note 1)	230 peak	°C

Maximum ratings are those values beyond which device damage can occur. Maximum ratings applied to the device are individual stress limit values (not normal operating conditions) and are not valid simultaneously. If these limits are exceeded, device functional operation is not implied, damage may occur and reliability may be affected.

1. 60 second maximum above 183°C.



ON Semiconductor®

<http://onsemi.com>

MARKING DIAGRAM

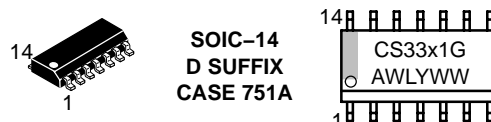

CS33x1 = Specific Device Code
 x = 4 or 5
 A = Assembly Location
 WL = Wafer Lot
 Y = Year
 WW = Work Week
 G = Pb-Free Package

PIN CONNECTIONS

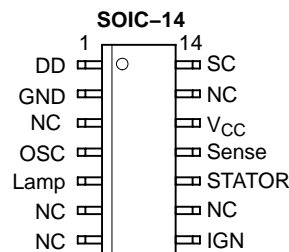

Flip Chip, Bump Side Up

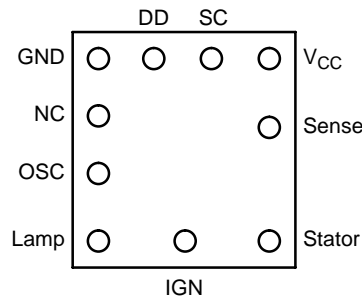

ORDERING INFORMATION

See detailed ordering and shipping information in the package dimensions section on page 4 of this data sheet.

*For additional information on our Pb-Free strategy and soldering details, please download the ON Semiconductor Soldering and Mounting Techniques Reference Manual, SOLDERRM/D.

CS3341, CS3351, CS387

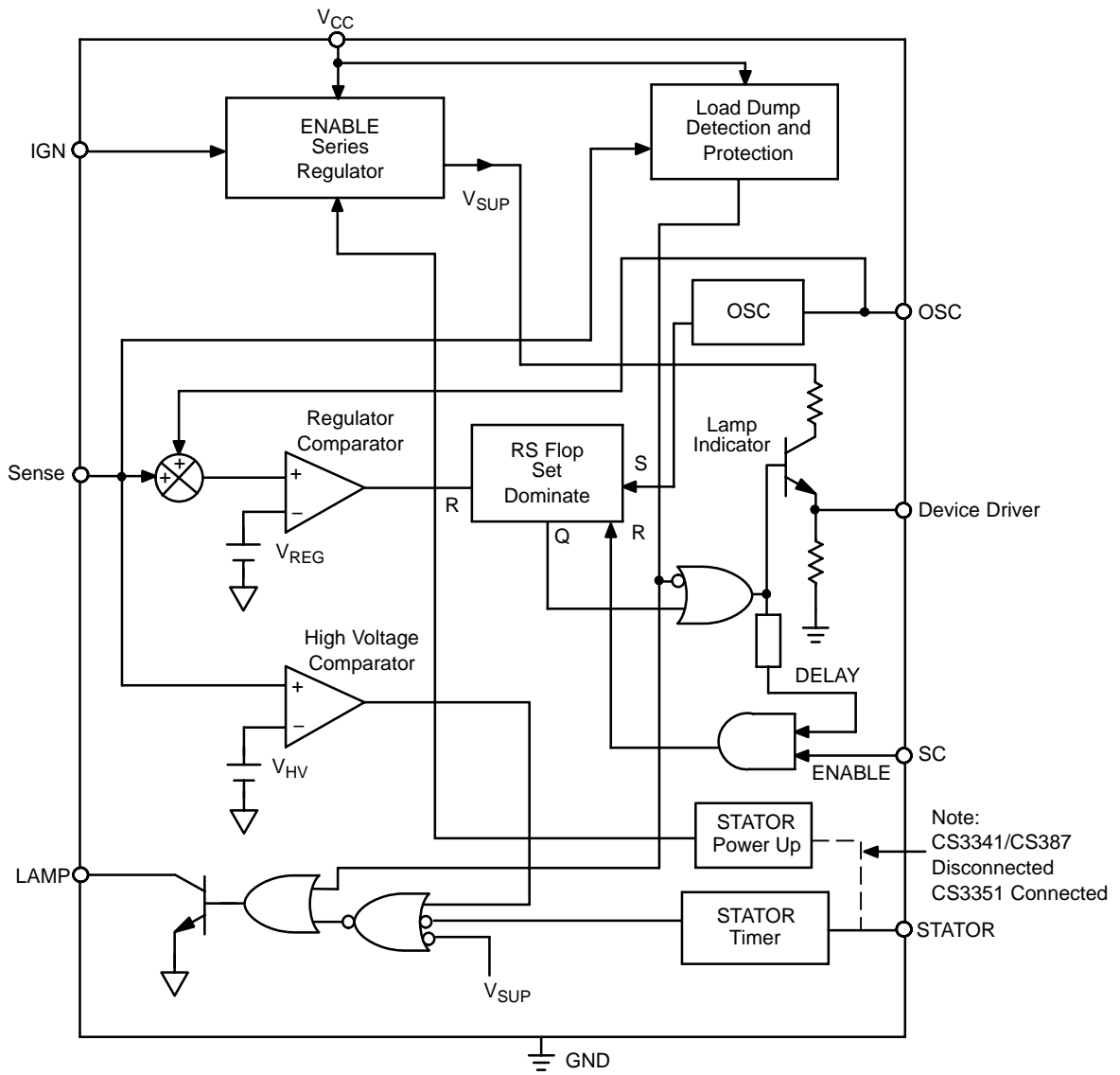

Figure 1. Block Diagram

CS3341, CS3351, CS387

ELECTRICAL CHARACTERISTICS ($-40^{\circ}\text{C} < T_A < 125^{\circ}\text{C}$, $-40^{\circ}\text{C} < T_J < 150^{\circ}\text{C}$, $9.0\text{ V} \leq V_{CC} \leq 17\text{ V}$; unless otherwise specified.)

Characteristic	Test Conditions	Min	Typ	Max	Unit
----------------	-----------------	-----	-----	-----	------

Supply

Supply Current Enabled	–	–	12	25	mA
Supply Current Disabled	–	–	–	50	μA

Driver Stage

Output High Current	$V_{DD} = 1.2\text{ V}$	–10	–6.0	–4.0	mA
Output Low Voltage	$I_{OL} = 25\ \mu\text{A}$	–	–	0.35	V
Minimum ON Time	–	200	–	–	μs
Minimum Duty Cycle	–	–	6.0	10	%
Short Circuit Duty Cycle	–	1.0	–	5.0	%
Field Switch Turn On Rise Time	–	30	–	90	μs
Field Switch Turn On Fall Time	–	30	–	90	μs

Stator

Input High Voltage	–	10	–	–	V
Input Low Voltage	–	–	–	6.0	V
Stator Time Out	High to Low	6.0	100	600	ms
Stator Power-Up Input High	CS3351 only	10	–	–	V
Stator Power-Up Input Low	CS3351 only	–	–	6.0	V

Lamp

Output High Current	$V_{LAMP} @ 3.0\text{ V}$	–	–	50	μA
Output Low Voltage	$I_{LAMP} @ 30\text{ mA}$	–	–	0.35	V

Ignition

Input High Voltage	$I_{CC} > 1.0\text{ mA}$	1.8	–	–	V
Input Low Voltage	$I_{CC} < 100\ \mu\text{A}$	–	–	0.5	V

Oscillator

Oscillator Frequency	$C_{OSC} = 0.22\ \mu\text{F}$	65	–	325	Hz
Rise Time/Fall Time	$C_{OSC} = 0.22\ \mu\text{F}$	–	17	–	–
Oscillator High Threshold	$C_{OSC} = 0.22\ \mu\text{F}$	–	–	6.0	V

Battery Sense

Input Current	–	–10	–	+10	μA
Regulation Voltage	@25°C, $R_1 = 100\text{ k}\Omega$, $R_2 = 50\text{ k}\Omega$	13.5	–	16	V
Proportional Control	–	0.050	–	0.400	V
High Voltage Threshold Ratio	$\frac{V_{\text{High Voltage @ Lamp On}}}{V_{\text{Regulation @ 50\% Duty Cycle}}}$	1.083	–	1.190	–
High Voltage Hysteresis	–	0.020	–	0.600	V

CS3341, CS3351, CS387

PACKAGE PIN DESCRIPTION

PACKAGE PIN #		PIN SYMBOL	FUNCTION
SOIC-14	Flip Chip		
1	1	Driver	Output driver for external power switch-Darlington
2	2	GND	Ground
3, 6, 7, 9, 13	3	NC	No Connection
4	4	OSC	Timing capacitor for oscillator
5	5	Lamp	Base driver for lamp driver indicates no stator signal or overvoltage condition
8	6	IGN	Switched ignition powerup
10	7	Stator	Stator signal input for stator timer (CS3351 also powerup)
11	8	Sense	Battery sense voltage regulator comparator input and protection
12	9	V _{CC}	Supply for IC
14	10	SC	Short circuit sensing

ORDERING INFORMATION

Device	Package	Shipping [†]
CS3341YD14	SOIC-14	55 Units/Rail
CS3341YD14G	SOIC-14 (Pb-Free)	55 Units/Rail
CS3341YDR14	SOIC-14	2500 Tape & Reel
CS3341YDR14G	SOIC-14 (Pb-Free)	2500 Tape & Reel
CS3351YD14	SOIC-14	55 Units/Rail
CS3351YD14G	SOIC-14 (Pb-Free)	55 Units/Rail
CS3351YDR14	SOIC-14	2500 Tape & Reel
CS3351YDR14G	SOIC-14 (Pb-Free)	2500 Tape & Reel
CS387H	Flip Chip	Contact Sales

[†]For information on tape and reel specifications, including part orientation and tape sizes, please refer to our Tape and Reel Packaging Specifications Brochure, BRD8011/D.

TYPICAL PERFORMANCE CHARACTERISTICS

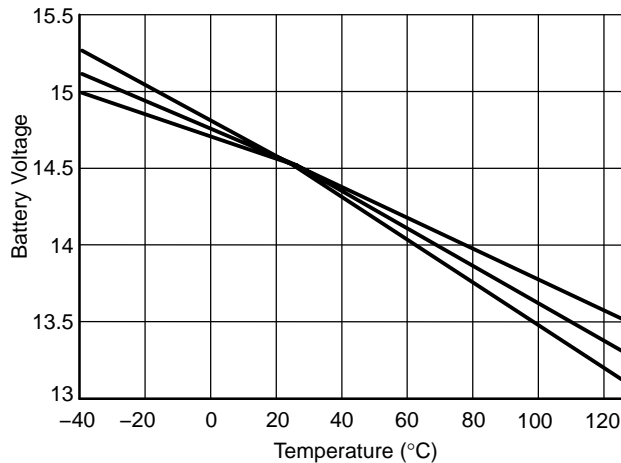

Figure 2. Battery Voltage vs. Temperature (°C) Over Process Variation

APPLICATIONS INFORMATION

The CS3341 and CS3351 IC's are designed for use in an alternator charging system. The circuit is also available in flip-chip form as the CS387.

In a standard alternator design (Figure 3), the rotor carries the field winding. An alternator rotor usually has several N and S poles. The magnetic field for the rotor is produced by forcing current through a field or rotor winding. The Stator windings are formed into a number of coils spaced around a cylindrical core. The number of coils equals the number of pairs of N and S poles on the rotor. The alternating current in the Stator windings is rectified by the diodes and applied to the regulator. By controlling the amount of field current, the magnetic field strength is controlled and hence the output voltage of the alternator.

Referring to Figure 7, a typical application diagram, the oscillator frequency is set by an external capacitor connected between OSC and ground. The sawtooth waveform ramps between 1.0 V and 3.0 V and provides the timing for the system. For the circuit shown the oscillator frequency is approximately 140 Hz. The alternator voltage is sensed at Terminal A via the resistor divider network R1/R2 on the Sense pin of the IC. The voltage at the sense pin determines the duty cycle for the regulator. The voltage is adjusted by potentiometer R2. A relatively low voltage on the sense pin causes a long duty cycle that increases the Field current. A high voltage results in a short duty cycle.

The ignition Terminal (I) switches power to the IC through the V_{CC} pin. In the CS3351 the Stator pin senses the voltage from the stator. This will keep the device powered while the voltage is high, and it also senses a stopped engine condition and drives the Lamp pin high after the stator

timeout expires. The Lamp pin also goes high when an overvoltage condition is detected on the sense pin. This causes the darlington lamp drive transistor to switch on and pull current through the lamp. If the system voltage continues to increase, the field and lamp output turn off as in an overvoltage or load dump condition.

The SC or Short Circuit pin monitors the field voltage. If the drive output and the SC voltage are simultaneously high for a predetermined period, a short circuit condition is assumed and the output is disabled. The regulator is forced to a minimum short circuit duty cycle.

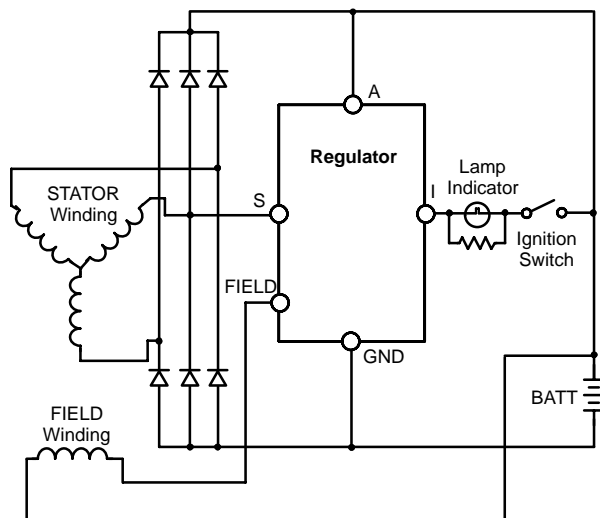

Figure 3. IAR System Block Diagram

REGULATION WAVEFORMS

The CS3341/3351/387 utilizes proportion control to maintain regulation. Waveforms depicting operation are shown in Figures 4, 5 and 6, where $V_{BAT/N}$ is the divided down voltage present on the Sense pin using R1 and R2 (Figure 7). A sawtooth waveform is generated internally. The amplitude of this waveform is listed in the electric parameter section as proportion control. The oscillator voltage is summed with $V_{BAT/N}$, and compared with the internal voltage regulator (V_{REG}) in the regulation

comparator which controls the field through the output "Device Driver."

Figure 4 shows typical steady-state operation. A 50% duty cycle is maintained.

Figure 5 shows the effect of a drop in voltage on ($V_{BAT/N} + V_{OSC}$). Notice the duty cycle increase to the field drive.

Figure 6 shows the effect of an increase in voltage (above the regulation voltage) on ($V_{BAT/N} + V_{OSC}$). Notice the decrease in field drive.

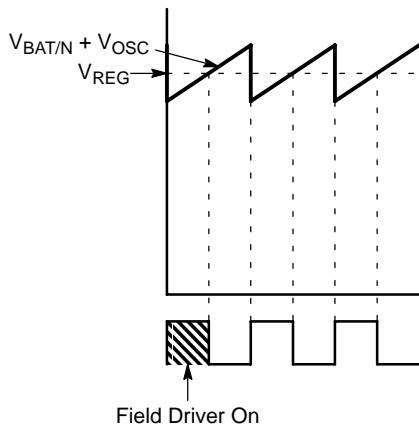

Figure 4. 50% Duty Cycle, Steady State

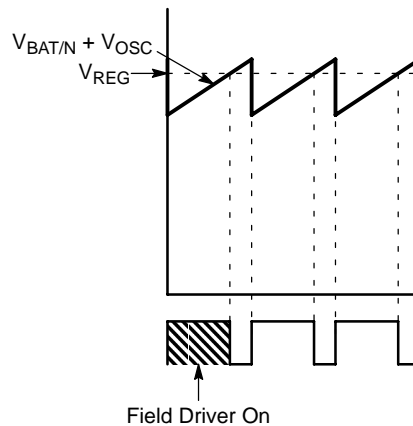

Figure 5. > 50% Duty Cycle, Increased Load

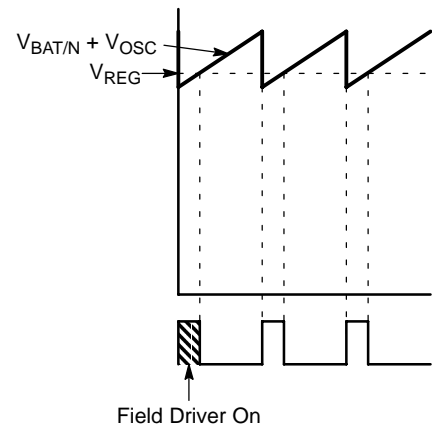

Figure 6. < 50% Duty Cycle, Decreased Load

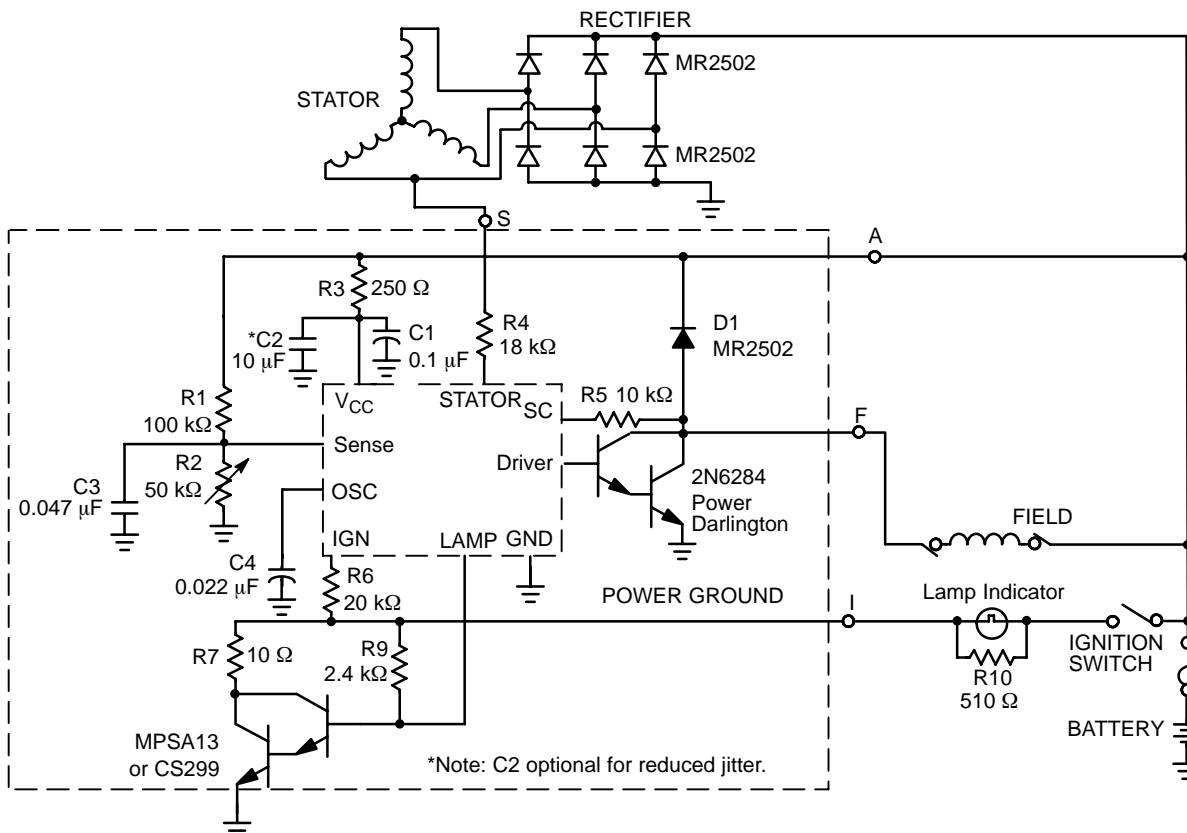

Figure 7. Typical Application Diagram

CS3341, CS3351, CS387

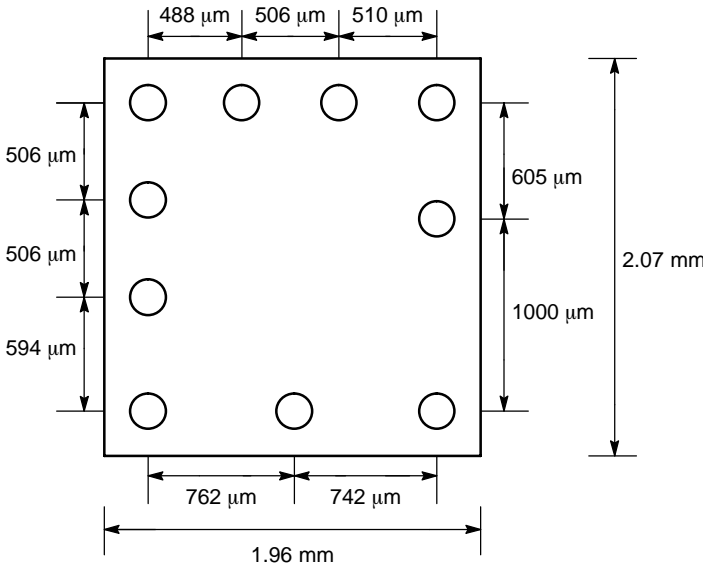
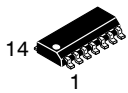

Figure 8. Flip Chip Dimensions and Solder Bump Locations, Bump Side Up

MECHANICAL CASE OUTLINE PACKAGE DIMENSIONS



SCALE 1:1

SOIC-14 NB
CASE 751A-03
ISSUE L

DATE 03 FEB 2016

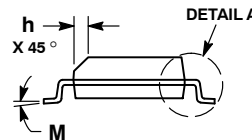
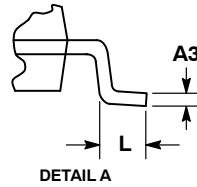
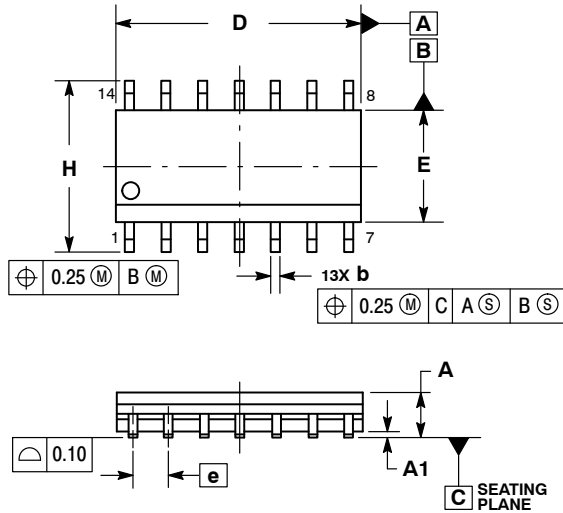

NOTES:

1. DIMENSIONING AND TOLERANCING PER ASME Y14.5M, 1994.
2. CONTROLLING DIMENSION: MILLIMETERS.
3. DIMENSION b DOES NOT INCLUDE DAMBAR PROTRUSION. ALLOWABLE PROTRUSION SHALL BE 0.13 TOTAL IN EXCESS OF AT MAXIMUM MATERIAL CONDITION.
4. DIMENSIONS D AND E DO NOT INCLUDE MOLD PROTRUSIONS.
5. MAXIMUM MOLD PROTRUSION 0.15 PER SIDE.

DIM	MILLIMETERS		INCHES	
	MIN	MAX	MIN	MAX
A	1.35	1.75	0.054	0.068
A1	0.10	0.25	0.004	0.010
A3	0.19	0.25	0.008	0.010
b	0.35	0.49	0.014	0.019
D	8.55	8.75	0.337	0.344
E	3.80	4.00	0.150	0.157
e	1.27 BSC		0.050 BSC	
H	5.80	6.20	0.228	0.244
h	0.25	0.50	0.010	0.019
L	0.40	1.25	0.016	0.049
M	0°	7°	0°	7°

SOLDERING FOOTPRINT*

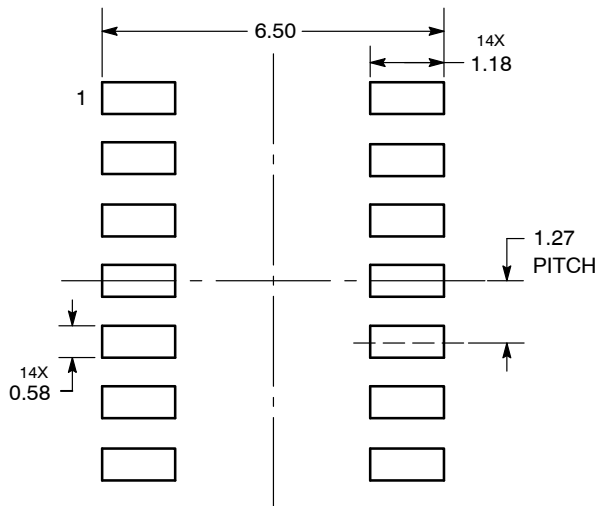

DIMENSIONS: MILLIMETERS

*For additional information on our Pb-Free strategy and soldering details, please download the ON Semiconductor Soldering and Mounting Techniques Reference Manual, SOLDERRM/D.

GENERIC MARKING DIAGRAM*

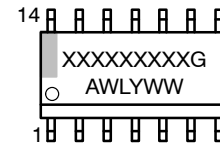

- XXXXXX = Specific Device Code
- A = Assembly Location
- WL = Wafer Lot
- Y = Year
- WW = Work Week
- G = Pb-Free Package

*This information is generic. Please refer to device data sheet for actual part marking. Pb-Free indicator, "G" or microdot "▪", may or may not be present. Some products may not follow the Generic Marking.

STYLES ON PAGE 2

DOCUMENT NUMBER:	98ASB42565B	Electronic versions are uncontrolled except when accessed directly from the Document Repository. Printed versions are uncontrolled except when stamped "CONTROLLED COPY" in red.
DESCRIPTION:	SOIC-14 NB	PAGE 1 OF 2

onsemi and onsemi are trademarks of Semiconductor Components Industries, LLC dba onsemi or its subsidiaries in the United States and/or other countries. onsemi reserves the right to make changes without further notice to any products herein. onsemi makes no warranty, representation or guarantee regarding the suitability of its products for any particular purpose, nor does onsemi assume any liability arising out of the application or use of any product or circuit, and specifically disclaims any and all liability, including without limitation special, consequential or incidental damages. onsemi does not convey any license under its patent rights nor the rights of others.

SOIC-14
CASE 751A-03
ISSUE L

DATE 03 FEB 2016

STYLE 1:
 PIN 1. COMMON CATHODE
 2. ANODE/CATHODE
 3. ANODE/CATHODE
 4. NO CONNECTION
 5. ANODE/CATHODE
 6. NO CONNECTION
 7. ANODE/CATHODE
 8. ANODE/CATHODE
 9. ANODE/CATHODE
 10. NO CONNECTION
 11. ANODE/CATHODE
 12. ANODE/CATHODE
 13. NO CONNECTION
 14. COMMON ANODE

STYLE 2:
 CANCELLED

STYLE 3:
 PIN 1. NO CONNECTION
 2. ANODE
 3. ANODE
 4. NO CONNECTION
 5. ANODE
 6. NO CONNECTION
 7. ANODE
 8. ANODE
 9. ANODE
 10. NO CONNECTION
 11. ANODE
 12. ANODE
 13. NO CONNECTION
 14. COMMON CATHODE

STYLE 4:
 PIN 1. NO CONNECTION
 2. CATHODE
 3. CATHODE
 4. NO CONNECTION
 5. CATHODE
 6. NO CONNECTION
 7. CATHODE
 8. CATHODE
 9. CATHODE
 10. NO CONNECTION
 11. CATHODE
 12. CATHODE
 13. NO CONNECTION
 14. COMMON ANODE

STYLE 5:
 PIN 1. COMMON CATHODE
 2. ANODE/CATHODE
 3. ANODE/CATHODE
 4. ANODE/CATHODE
 5. ANODE/CATHODE
 6. NO CONNECTION
 7. COMMON ANODE
 8. COMMON CATHODE
 9. ANODE/CATHODE
 10. ANODE/CATHODE
 11. ANODE/CATHODE
 12. ANODE/CATHODE
 13. NO CONNECTION
 14. COMMON ANODE

STYLE 6:
 PIN 1. CATHODE
 2. CATHODE
 3. CATHODE
 4. CATHODE
 5. CATHODE
 6. CATHODE
 7. CATHODE
 8. ANODE
 9. ANODE
 10. ANODE
 11. ANODE
 12. ANODE
 13. ANODE
 14. ANODE

STYLE 7:
 PIN 1. ANODE/CATHODE
 2. COMMON ANODE
 3. COMMON CATHODE
 4. ANODE/CATHODE
 5. ANODE/CATHODE
 6. ANODE/CATHODE
 7. ANODE/CATHODE
 8. ANODE/CATHODE
 9. ANODE/CATHODE
 10. ANODE/CATHODE
 11. COMMON CATHODE
 12. COMMON ANODE
 13. ANODE/CATHODE
 14. ANODE/CATHODE

STYLE 8:
 PIN 1. COMMON CATHODE
 2. ANODE/CATHODE
 3. ANODE/CATHODE
 4. NO CONNECTION
 5. ANODE/CATHODE
 6. ANODE/CATHODE
 7. COMMON ANODE
 8. COMMON ANODE
 9. ANODE/CATHODE
 10. ANODE/CATHODE
 11. NO CONNECTION
 12. ANODE/CATHODE
 13. ANODE/CATHODE
 14. COMMON CATHODE

DOCUMENT NUMBER:	98ASB42565B	Electronic versions are uncontrolled except when accessed directly from the Document Repository. Printed versions are uncontrolled except when stamped "CONTROLLED COPY" in red.
DESCRIPTION:	SOIC-14 NB	PAGE 2 OF 2

onsemi and **ONSEMI** are trademarks of Semiconductor Components Industries, LLC dba **onsemi** or its subsidiaries in the United States and/or other countries. **onsemi** reserves the right to make changes without further notice to any products herein. **onsemi** makes no warranty, representation or guarantee regarding the suitability of its products for any particular purpose, nor does **onsemi** assume any liability arising out of the application or use of any product or circuit, and specifically disclaims any and all liability, including without limitation special, consequential or incidental damages. **onsemi** does not convey any license under its patent rights nor the rights of others.

onsemi, **Onsemi**, and other names, marks, and brands are registered and/or common law trademarks of Semiconductor Components Industries, LLC dba "**onsemi**" or its affiliates and/or subsidiaries in the United States and/or other countries. **onsemi** owns the rights to a number of patents, trademarks, copyrights, trade secrets, and other intellectual property. A listing of **onsemi**'s product/patent coverage may be accessed at www.onsemi.com/site/pdf/Patent-Marking.pdf. **onsemi** reserves the right to make changes at any time to any products or information herein, without notice. The information herein is provided "as-is" and **onsemi** makes no warranty, representation or guarantee regarding the accuracy of the information, product features, availability, functionality, or suitability of its products for any particular purpose, nor does **onsemi** assume any liability arising out of the application or use of any product or circuit, and specifically disclaims any and all liability, including without limitation special, consequential or incidental damages. Buyer is responsible for its products and applications using **onsemi** products, including compliance with all laws, regulations and safety requirements or standards, regardless of any support or applications information provided by **onsemi**. "Typical" parameters which may be provided in **onsemi** data sheets and/or specifications can and do vary in different applications and actual performance may vary over time. All operating parameters, including "Typicals" must be validated for each customer application by customer's technical experts. **onsemi** does not convey any license under any of its intellectual property rights nor the rights of others. **onsemi** products are not designed, intended, or authorized for use as a critical component in life support systems or any FDA Class 3 medical devices or medical devices with a same or similar classification in a foreign jurisdiction or any devices intended for implantation in the human body. Should Buyer purchase or use **onsemi** products for any such unintended or unauthorized application, Buyer shall indemnify and hold **onsemi** and its officers, employees, subsidiaries, affiliates, and distributors harmless against all claims, costs, damages, and expenses, and reasonable attorney fees arising out of, directly or indirectly, any claim of personal injury or death associated with such unintended or unauthorized use, even if such claim alleges that **onsemi** was negligent regarding the design or manufacture of the part. **onsemi** is an Equal Opportunity/Affirmative Action Employer. This literature is subject to all applicable copyright laws and is not for resale in any manner.

ADDITIONAL INFORMATION

TECHNICAL PUBLICATIONS:

Technical Library: www.onsemi.com/design/resources/technical-documentation
onsemi Website: www.onsemi.com

ONLINE SUPPORT: www.onsemi.com/support

For additional information, please contact your local Sales Representative at www.onsemi.com/support/sales