

PART NUMBER	REV	FIRST USED
680724 -1	B	354500-1
680724 -2	B	565435-5

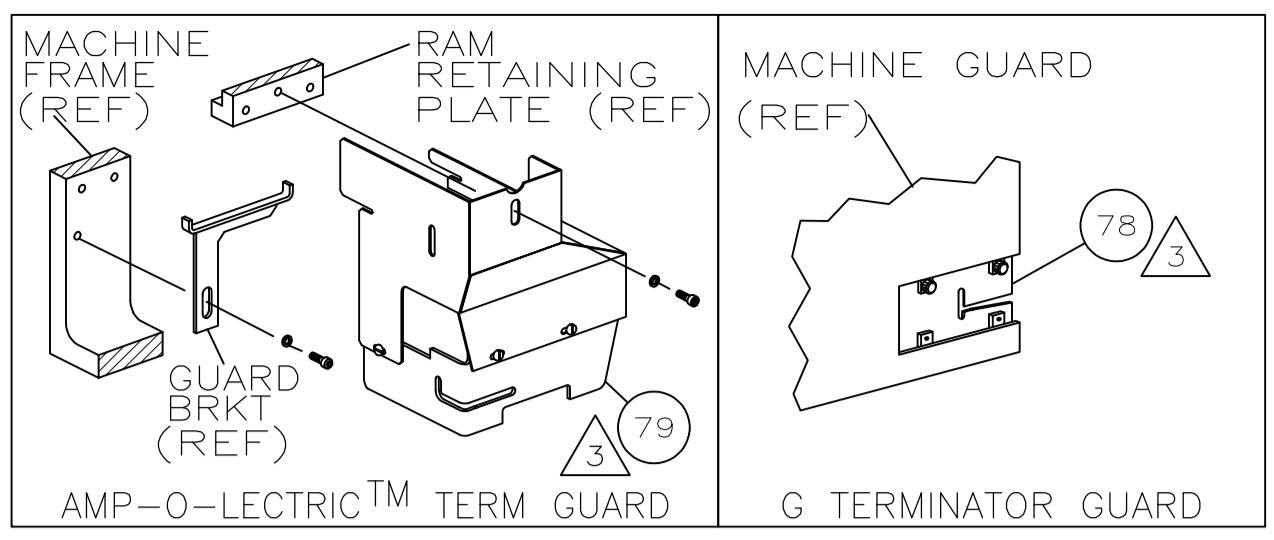

TERMINAL NAME: RECEPTACLE, FASTON [™] .110 SERIES			
1217048 CRIMP DATA (AMP TERMINAL)			
PAD LTR	CRIMP HEIGHT	WIRE SIZE	
A	NOT	USED	
B	NOT	USED	
C	NOT	USED	
D	NOT	USED	
CRIMP	SIZE	TYPE	RANGE
WIRE	-	-	-
INSUL	-	-	-
WIRE STRIP LENGTH	TERM APPL SPEC	FEED	APPL INSTRUCTION
-	NONE	.535	408-8039
		SET UP GAGE	LAYOUT
		458638-1	L2160

LOC	DIST	REVISIONS			
F	LTR	DESCRIPTION	DATE	BY	APPV
A	66	ECR-09-015272	7-2009	MY	TE

-1	BENCH MODEL G	AIR FEED
-2	BENCH MODEL K	AIR FEED

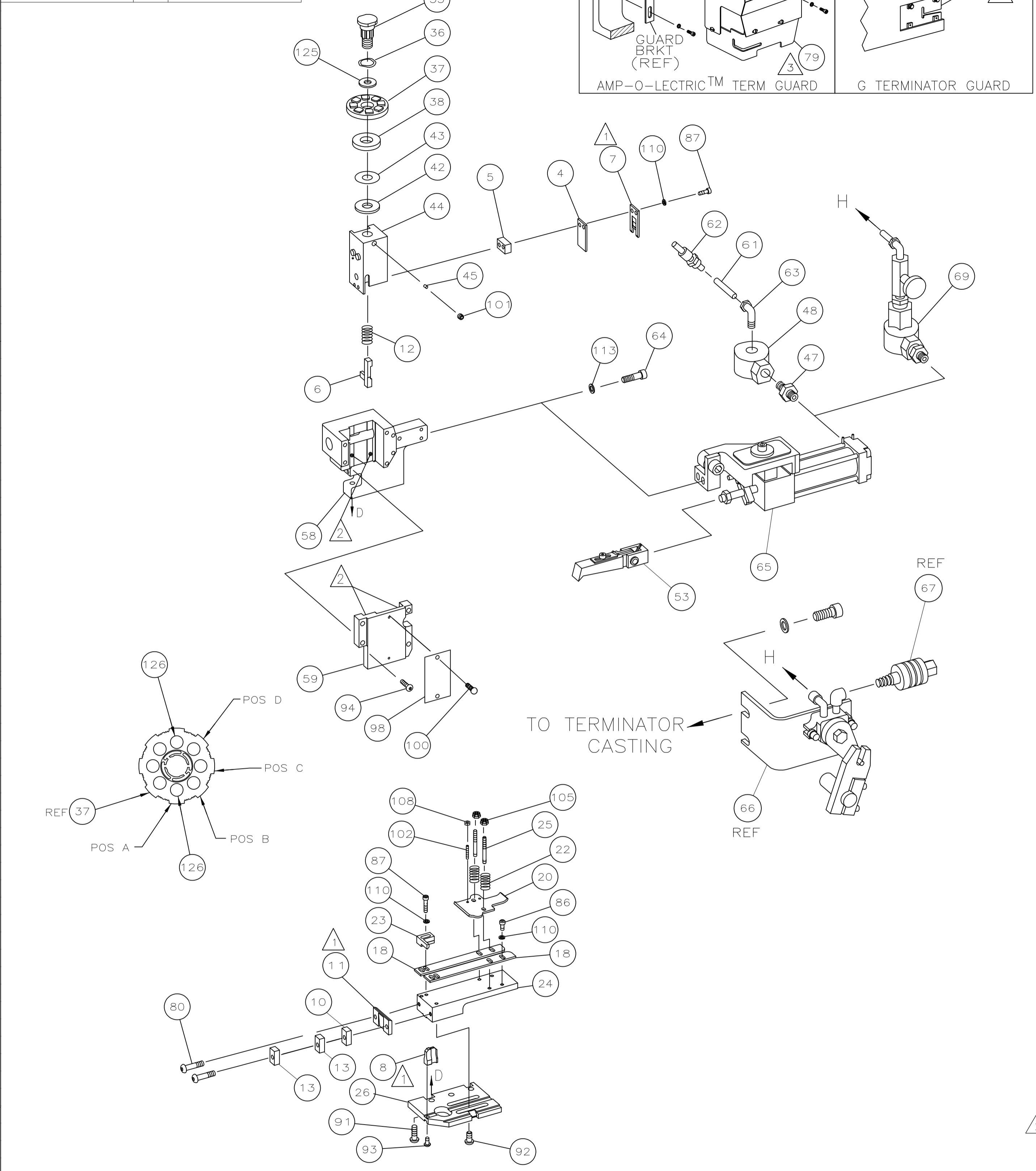

					129
					128
					127
2	2	-	354779-8	PIN, WIRE DISC (.3030)A	126
1	1	-	986950-1	WASHER, FLAT PRECISION	125
1	1	-	217238-1	GENERAL INSTRUCTION PACKAGE	124
1	1	-	4088039	EF APPL INST 408-8039	123
					122
					121
					120
					119
					118
					117
					116
					115
					114
2	2	-	21024-5	WASHER, LOCK(#10)AIR ASSY	113
					112
					111
7	7	-	21024-4	WASHER, LOCK(NO.8)SHEAR BL	110
					109
2	2	-	21018-4	NUT, HEX(4-40)DRAG	108
					107
					106
2	2	-	21022-2	NUT, HEX SL(8-32)DRAG STUD	105
					104
					103
2	2	-	2-21006-6	SCR, SKT SET(4-40x.62)DRAG	102
1	1	-	21009-2	SCR, SKT SET(1/4-20x.25)RAM	101
2	2	-	21017-2	SCR, DRIVE(#2x.19)ID PLATE	100
					99
1	1	-	461264-1	PLATE, IDENTIFICATION	98
					97
					96
					95
4	4	-	2-21002-9	SCR, BHC(10-32x.75)CAP	94
1	1	-	22733-8	SCR, BHC(8-32x.38 LW)ANVIL	93
4	4	-	3-21002-3	SCR, BHC(1/4-20x.50)ST GD PL	92
3	3	-	2-22733-8	SCR, BHC(1/4-20x.62)HSG	91
					90
					89
					88
					87
4	4	-	2-21000-7	SCR, SHC(8-32x.50)SLUG BLADE	86
3	3	-	2-21000-5	SCR, SHC(8-32x.25)STRIP GUIDE	85
					84
					83
					82
					81
2	2	-	3-21002-0	SCR, BHC(10-32x.88)SHEAR PL	80
1	-	-	455750-8	GUARD ASSY	79
-	REF	-	679532-1	INSERT, GUARD	78
					77
					76
-	1	-	22317-3	ELBOW, COPPER TUBE	75
					74
					73
					72
					71
-2	-1	U/M	PART NO	DESCRIPTION	ITEM NO
PARTS LIST					
QTY REQD PER ASSY					

					70
4	1	-	692655-5	AIR FEED VALVE ASSY	69
					68
					67
REF	-	-	24042-2	VALVE, SHUT OFF	66
4	1	1	460277-1	AIR FEED ASSY (1 INCH)	65
					64
2	2	-	3-21000-9	SCR, SHC(10-32x1.00)AIR ASSY	63
-	1	-	980285-2	ELBOW, SWIVEL 1/8 NPT - 1/4 T	62
-	1	-	23238-1	QUICK DISCONNECT	61
-	12.00	IN	27319-4	TUBING, POLY-FLO Ø.25	60
					59
1	1	-	454220-1	CAP, RAM	58
1	1	-	453736-1	HOUSING	57
					56
					55
					54
4	1	1	460680-2	FEED FINGER ASSY	53
					52
					51
-	1	-	318848-1	AIR BLAST ASSEMBLY	50
1	-	-	455350-1	AIR BLAST ASSEMBLY	49
-	1	-	22374-7	VALVE, QUICK EXHAUST	48
-	1	-	22304-1	NIPPLE, HEX 1/8 NPT	47
-	1	-	689446-2	TUBE, AIR BLAST	46
1	1	-	690191-1	PLUG, NYLON	45
1	1	-	455674-1	RAM	44
1	1	-	690125-1	WASHER, LAMINATED	43
1	1	-	690124-1	WASHER, RAM	42
					41
					40
					39
1	1	-	690223-2	SPACER, INSULATION DISC	38
1	1	-	354777-1	WIRE DISC, PLASTIC	37
1	1	-	22480-5	WASHER, SPRING	36
1	1	-	690212-1	POST, RAM	35
					34
					33
					32
					31
					30
					29
					28
					27
1	1	-	455676-1	PLATE, BASE	26
2	2	-	22354-8	DRAG, STUD	25
1	1	-	455678-5	PLATE, STRIP GUIDE	24
1	1	-	240825-7	PLATE, STRIP HOLD DOWN	23
2	2	-	4-22281-1	SPRING, DRAG	22
					21
					20
1	1	-	454177-1	DRAG, STOCK	19
					18
2	2	-	454204-9	GUIDE, STRIP (FRONT)	17
					16
					15
					14
2	2	-	690481-2	SPACER, HOLD DOWN	13
1	1	-	23846-2	SPRING, HOLD DOWN	12
1	1	-	240644-8	PLATE, REAR SHEAR	11
1	1	-	2-240645-7	SPACER	10
					9
1	1	-	318775-2	ANVIL	8
1	1	-	2-691157-0	BLADE, SLUG	7
1	1	-	6-455892-4	HOLD DOWN, TERMINAL	6
1	1	-	3-240641-6	SPACER, SLUG BLADE	5
1	1	-	690639-3	BENDING TOOL	4
					3
					2
					1
-2	-1	U/M	PART NO	DESCRIPTION	ITEM NO
PARTS LIST					
QTY REQD PER ASSY					

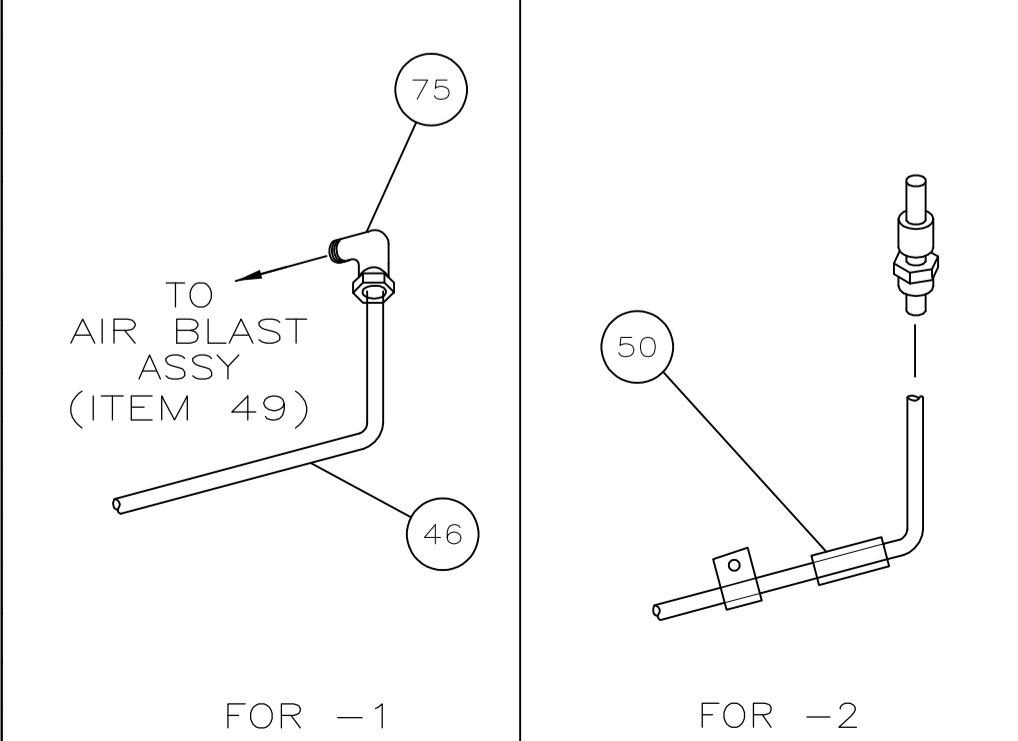

- 1 RECOMMENDED SPARE PARTS.
- 3 GUARD MUST BE IN PLACE WHEN OPERATING APPLICATOR IN A BENCH MACHINE.
- 4 SEE DRAWING FOR COMPONENTS
- 5 ITEM 78 USED WITH G TERMINATOR ONLY.
- 6 TERMINAL BENT DOWN 85±5° APPLICATOR DOES NOT CRIMP THE TERMINAL LOOSE PIECE APPLICATOR
- 7 THIS PAD TO BE USED FOR BENDING.

THIS DRAWING IS A CONTROLLED DOCUMENT.

DIMENSIONS: INCHES	TOLERANCES UNLESS OTHERWISE SPECIFIED:	DIN P. Mathias 26OCT98	Tyco Electronics Corporation Harrisburg, PA 17105-3608
0 PLC ± .005	1 PLC ± .005	26OCT98	
1 PLC ± .005	2 PLC ± .005	26OCT98	Tyco Electronics
3 PLC ± .005	4 PLC ± .005	26OCT98	
4 PLC ± .005	ANGLES ± .005	APPROV: J. ELBIN	END FEED HDM APPLICATOR
MATERIAL	FINISH	SIZE: A1	CAGE CODE: 00779
		WEIGHT	DRAWING NO: 680724
		CUSTOMER DRAWING	SCALE: 1 OF 1