

4

3

2

1

THIS DRAWING IS UNPUBLISHED. RELEASED FOR PUBLICATION
 BY AMP INCORPORATED, ALL RIGHTS RESERVED.

LOC	DIST	REVISIONS					
		P	LTR	DESCRIPTION	DATE	DWN	APVD
G	86	B		REV PER 063A-0561-01	090CT02	JR	MS

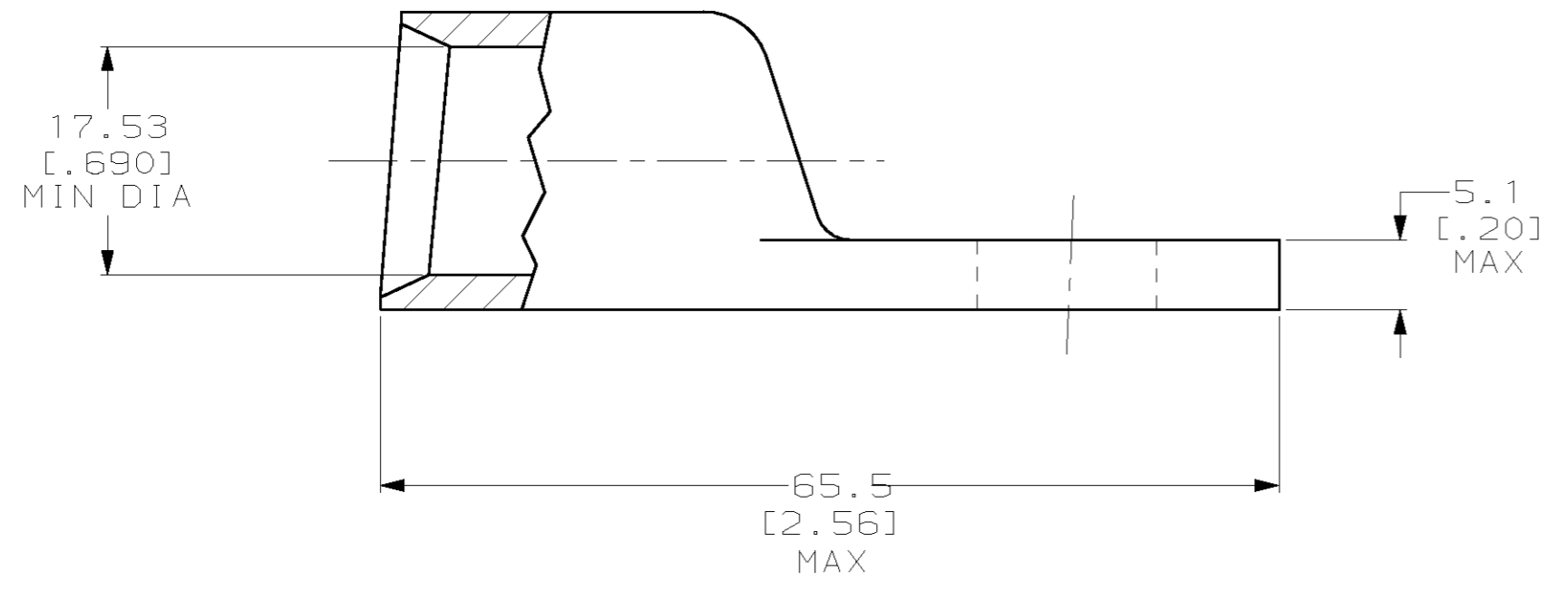
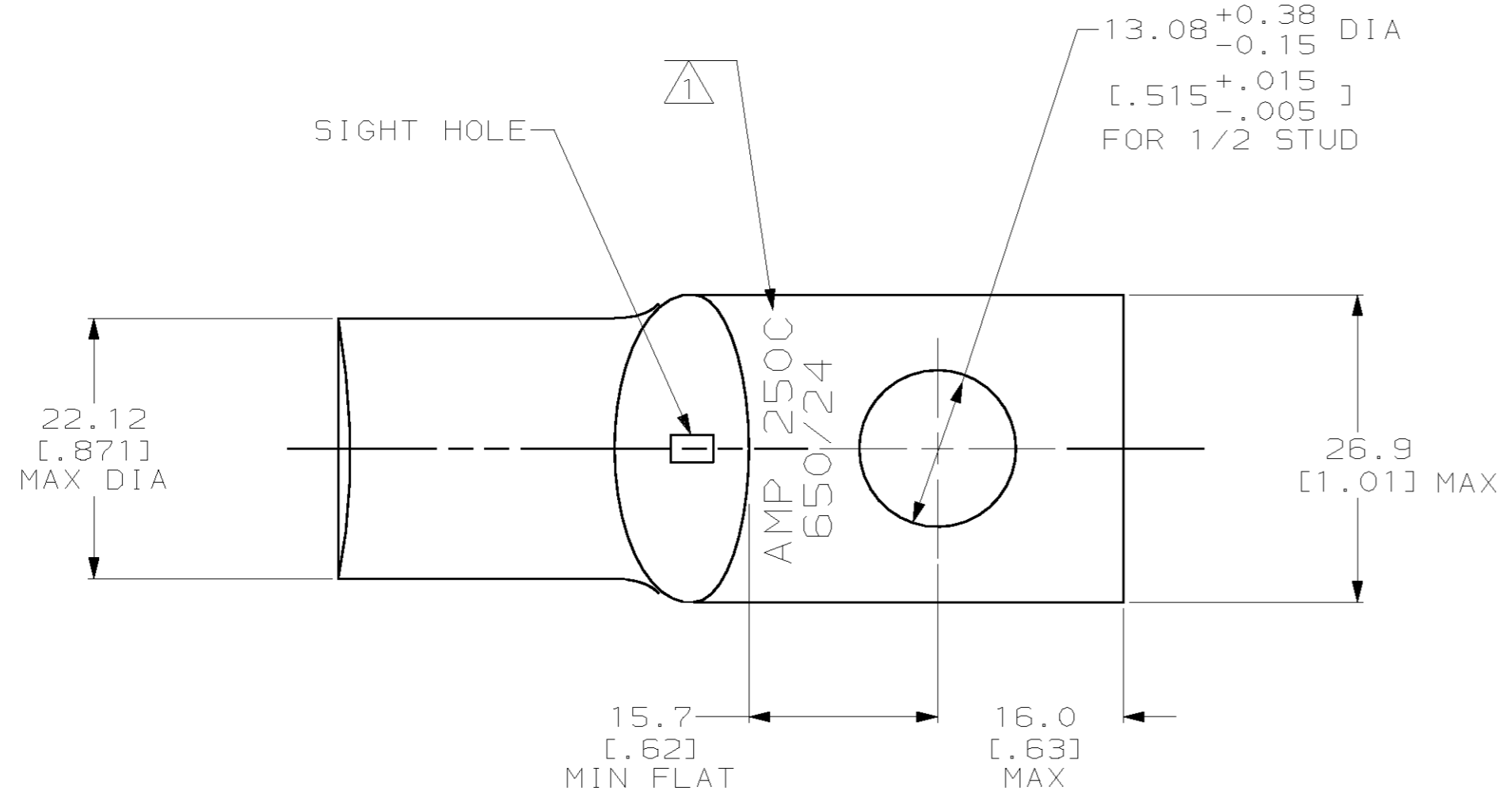

696027-1
 AMP
 PART NUMBER

<small>THIS DRAWING IS A CONTROLLED DOCUMENT FOR AMP INCORPORATED. IT IS SUBJECT TO CHANGE AND THE CONTROLLING ENGINEERING ORGANIZATION SHOULD BE CONTACTED FOR THE LATEST REVISION.</small>		DWN DK SCHRUM 20MAY96 CHK WJ VOCKROTH 21MAY96 APVD JL MECKLEY 21MAY96	AMP AMP Incorporated Harrisburg, PA 17105-3608
DIMENSIONS: mm [INCHES]	TOLERANCES UNLESS OTHERWISE SPECIFIED: 0 PLC ±- 1 PLC ±- 2 PLC ±- 3 PLC ±- 4 PLC ±- ANGLES ±-	PRODUCT SPEC 108-30200 APPLICATION SPEC -	NAME TERMINAL, SPECIAL, AMPOWER, WIRE SIZE: 250 MCM
MATERIAL COPPER PER ASTM B-75 ANNEALED	FINISH TIN PLATE 0.00381 [.000150] MIN THK PER ASTM B-545	WEIGHT .124 lbs	SIZE A2 CAGE CODE 00779 DRAWING NO C-696027
CUSTOMER DRAWING			SCALE 2:1 SHEET 1 OF 1 REV B

696027