

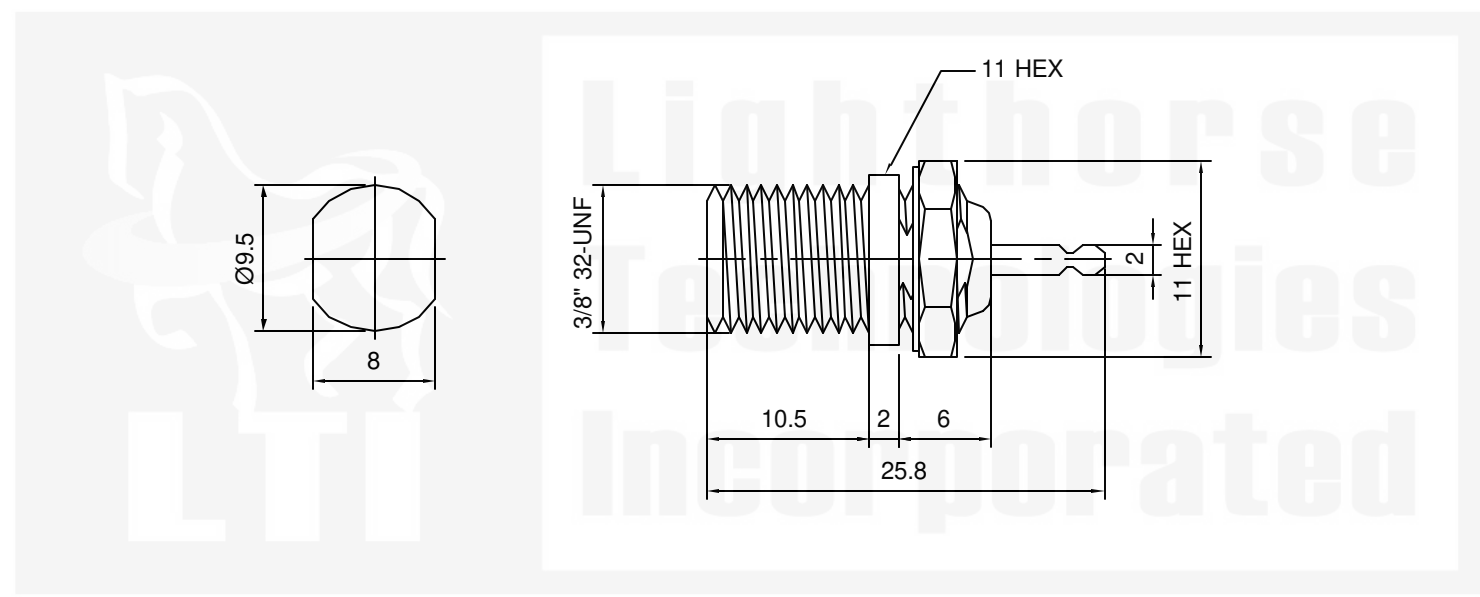

**Tolerances**  
 1-20=+/-0.2  
 20-30=+/-0.3  
 30-40=+/-0.4  
 40-50=+/-0.5  
 50-100=+/-0.75  
 100-300=+/-1.5  
 Angles=+/-1  
 Dimensions are in Millimeters

Revisions Description/Approved/Date	Approved M.H.	Date 01/25/99
	Checked M.H.	Date 01/25/99
	Drawn K.R.E.	Date 01/21/99
NOTES (plating thickness in micro-inches): 1. Per QQ-B-626 2. Per QQ-S-764 3. Per QQ-C-530 4. Per QQ-B-750 5. Per MIL-P-19468 6. Per ZZ-R-765 7. Per WW-T-799 8. Gold pl. 5 min. over nickel pl. 50 min. over copper strike 9. Nickel pl. 100 min. over copper strike 10. Per QQ-P-35 11. Gold pl. 30 min. over nickel pl. 50 min. over copper strike		



ITEM	MATERIAL	FINISH	 Light horse Technologies, Inc. 4907 Morena Boulevard, #1411 San Diego, California 92117 Part Number: <b>LTI-FSF73NP</b>		
Connector Body	Brass, Note 1	Nickel, Note 9	Description F front mount bulkhead jack with solder tab termination.  Nickel plated brass body, polypropylene dielectric		
Center Contact: Female	Beryllium Copper, Note 3	Tin			
Insulation	Polypropylene	None			
Ferrule	--	--			
Gasket	--	--			
Hex Nut	Brass, Note 1	Same as body	Scale	Drawing No.	File Name
Lock Washer	Brass, Note 1	Same as body	2:1	F/FSF73	FSF73