

13	12	11	10	9	8	7	6	5	4	3	2	1		
MATERIAL NUMBER LOOSE PCS	ENGINEERING NUMBER LOOSE PCS	MATERIAL NUMBER ON STRIP	ENGINEERING NUMBER ON STRIP	MATERIAL NUMBER ON TAPE	ENGINEERING NUMBER ON TAPE	ACCEPTS TAB SIZE	STOCK THK REF	OD MAX	ID MIN	MWID	"A" MAX	"B" MAX	"G" MAX	"H" REF
192770002	AA-5261-LIF	192770001	AA-5261Z-LIF	192770003	AA-5261T-LIF	.250 X .032	.016/0.41	.19/4.8	.056/1.42	.12/3.0	.89/22.6	.38/9.7	.20/5.1	1.43/36.2
192770005	BB-5263-LIF	192770004	BB-5263Z-LIF	192770006	BB-5263T-LIF	.250 X .032	.016/0.41	.22/5.6	.079/2.00	.14/3.6	.89/22.6	.38/9.7	.20/5.1	1.43/36.2
192770008	C-5293-LIF	192770007	C-5293Z-LIF	192770009	C-5293T-LIF	.250 X .032	.018/0.46	.32/8.1	.117/2.97	.23/5.8	1.02/25.9	.39/9.9	.24/6.1	1.51/38.4

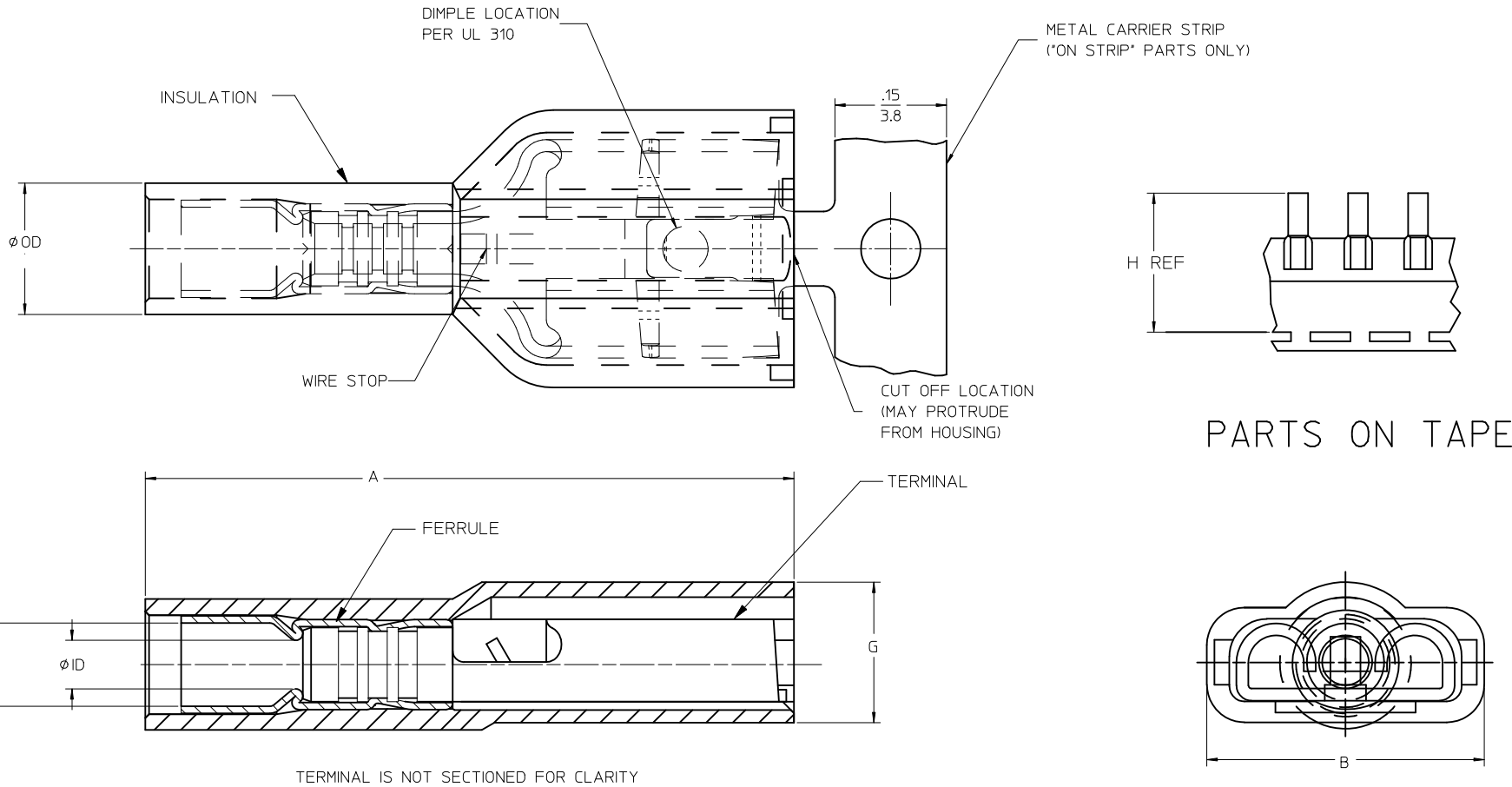

SALES DRAWING

- NOTES:
- MATERIALS:  
 TERMINAL: MATTE-TIN PLATED BRASS  
 FERRULE: MATTE-TIN PLATED COPPER ALLOY  
 INSULATION: NYLON 6/6 94V-2,  
 SEE CHART FOR COLORS
  - PRODUCT SPECIFICATION: PS-19902-012
  - MWID = MAXIMUM WIRE INSULATION DIAMETER
  - PARTS ARE ROHS COMPLIANT

RELEASE EC NO: WNA2009-0761 DRAWN: ETHRODAHL 2010/03/17 CHKD: JMACNEIL 2010/03/17 APPR: JMACNEIL 2011/01/06 REV A	QUALITY SYMBOLS ▽=0 ▽=0	GENERAL TOLERANCES (UNLESS SPECIFIED) <table border="1"> <thead> <tr> <th></th> <th>mm</th> <th>INCH</th> </tr> </thead> <tbody> <tr> <td>4 PLACES</td> <td>± .005</td> <td>± .0005</td> </tr> <tr> <td>3 PLACES</td> <td>± .010</td> <td>± .0010</td> </tr> <tr> <td>2 PLACES</td> <td>± 0.13</td> <td>± .010</td> </tr> <tr> <td>1 PLACE</td> <td>± 0.25</td> <td>± .020</td> </tr> </tbody> </table>		mm	INCH	4 PLACES	± .005	± .0005	3 PLACES	± .010	± .0010	2 PLACES	± 0.13	± .010	1 PLACE	± 0.25	± .020	DIMENSION STYLE IN/MM DRAWN BY DATE ETHRODAHL 2010/03/17 CHECKED BY DATE JMACNEIL 2010/03/17 APPROVED BY DATE JMACNEIL 2011/01/06	SCALE 1:1 DESIGN UNITS INCH THIRD ANGLE PROJECTION	TITLE QUIXON LOW INSERT FORCE FULLY INSUL QUICK DISCNT AVIKRIMP 22-10 AWG MOLEX INCORPORATED DOCUMENT NO. SD-19277-001 SHEET NO. 1 OF 1
		mm	INCH																	
	4 PLACES	± .005	± .0005																	
	3 PLACES	± .010	± .0010																	
2 PLACES	± 0.13	± .010																		
1 PLACE	± 0.25	± .020																		
DRAFT WHERE APPLICABLE MUST REMAIN WITHIN DIMENSIONS		SEE CHART	THIS DRAWING CONTAINS INFORMATION THAT IS PROPRIETARY TO MOLEX INCORPORATED AND SHOULD NOT BE USED WITHOUT WRITTEN PERMISSION																	