

High Performance Differential MEMS Oscillators for Automotive

Features

- Automotive AEC-Q100 Qualified
- Any Frequency between 2.5 MHz and 450 MHz
- Supports LVPECL, LVDS, or HCSL Differential Outputs
- Very Low RMS Phase Jitter: <650 fs (typ.)
- Complies with PCIe Gen1/2/3/4/5 Common Clock Spec
- High Stability: ± 20 ppm, ± 25 ppm, ± 50 ppm
- Wide Temperature Range:
 - Automotive Grade 1: -40°C to $+125^{\circ}\text{C}$ (DSA12x3 LVDS Output Only)
 - Automotive Grade 2: -40°C to $+105^{\circ}\text{C}$
 - Automotive Grade 3: -40°C to $+85^{\circ}\text{C}$
- Small Industry-Standard Footprints
 - 2.5 mm x 2.0 mm
 - 3.2 mm x 2.5 mm
 - 5.0 mm x 3.2 mm
 - 7.0 mm x 5.0 mm
- Excellent Shock and Vibration Immunity
 - Qualified to MIL-STD-883
- High Reliability
 - 20x Better MTF than Quartz Oscillators
- Supply Range of 2.25V to 3.63V
- Standby, Frequency Select, and Output Enable Functions
- Lead-Free and RoHS-Compliant

Applications

- Automotive Infotainment
- Automotive ADAS
- In-Vehicle Networking, CAN Bus, Ethernet

General Description

The DSA12x2/3/4 family of high performance oscillators utilizes the latest generation of silicon MEMS technology that reduces close-in noise and provides excellent jitter and stability over a wide range of supply voltages and temperatures. By eliminating the need for quartz or SAW technology, MEMS oscillators significantly enhance reliability and accelerate product development, while meeting stringent clock performance criteria for automotive applications.

The DSA12x2/3/4 family features a control function on pin 1 or pin 2 that permits either a standby feature (complete power down when $\overline{\text{STDBY}}$ is low), output enable (output is tri-stated with OE low), or a frequency select (choice of two frequencies selected by FS high/low). See the [Product Identification System](#) section for detailed information.

All oscillators are available in industry-standard packages, including the small 2.5 mm x 2.0 mm, and are “drop-in” replacements for standard 6-pin LVPECL/LVDS/HCSL crystal oscillators.

Package Types

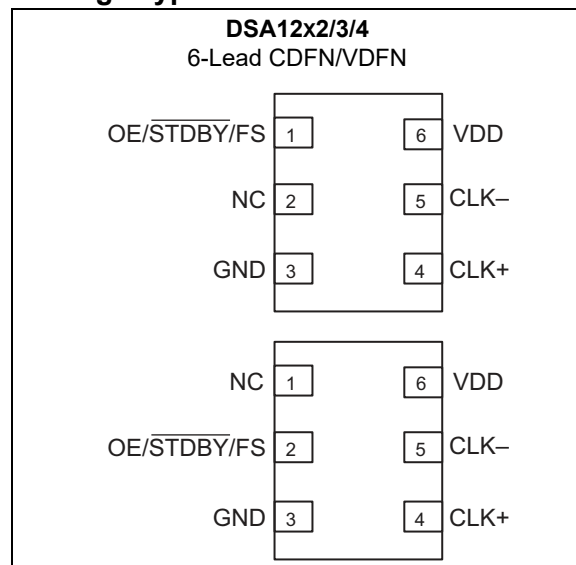

DSA12X2/3/4

Functional Block Diagrams

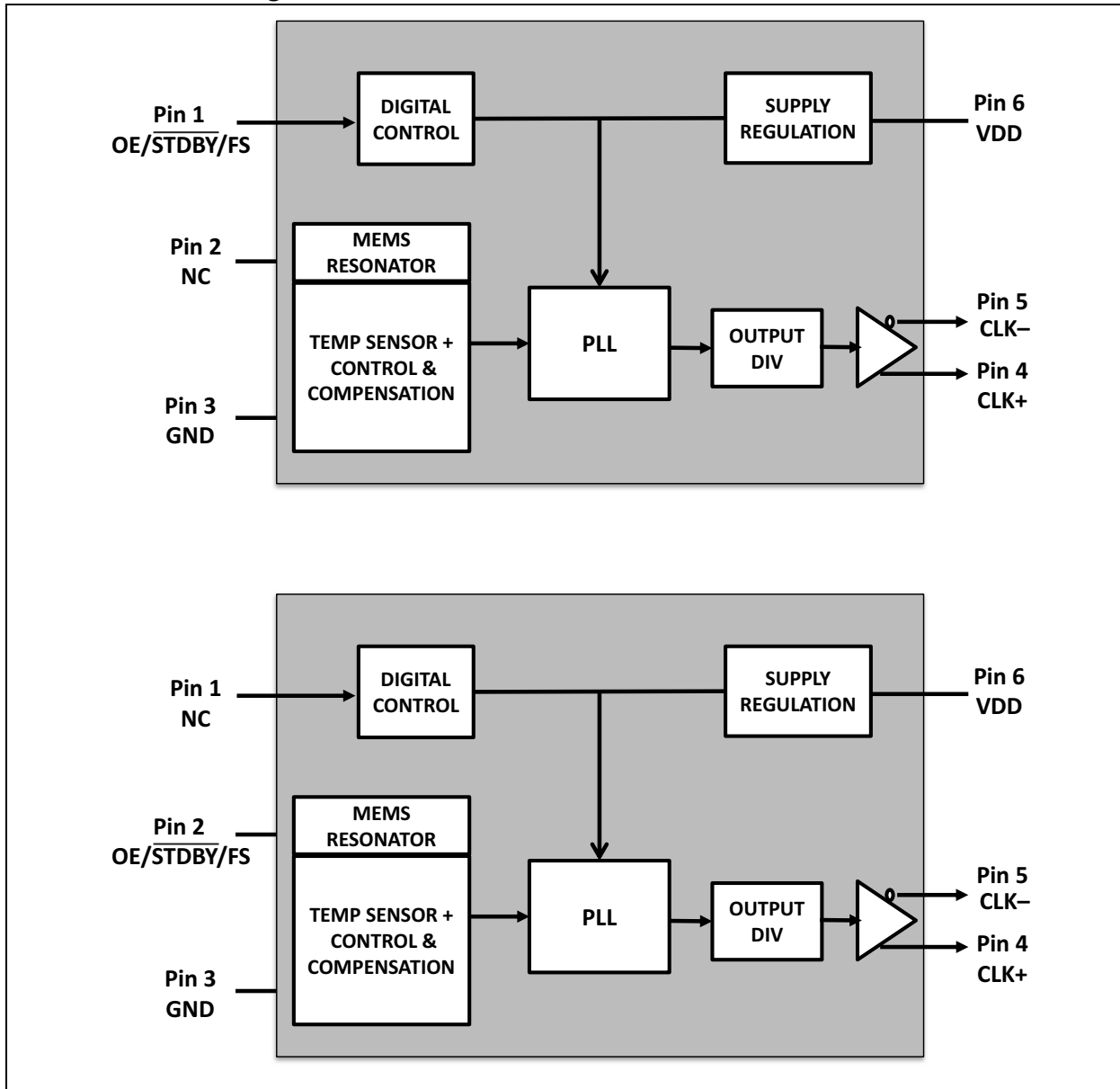

1.0 ELECTRICAL CHARACTERISTICS

Absolute Maximum Ratings †

Supply Voltage	-0.3V to +4.0V
Input Voltage	-0.3V to $V_{DD} + 0.3V$
ESD Protection (HBM)	4 kV
ESD Protection (MM)	400V
ESD Protection (CDM)	1.5 kV

† **Notice:** Stresses above those listed under “Absolute Maximum Ratings” may cause permanent damage to the device. This is a stress rating only and functional operation of the device at those or any other conditions above those indicated in the operational sections of this specification is not intended. Exposure to maximum rating conditions for extended periods may affect device reliability.

ELECTRICAL CHARACTERISTICS

Electrical Characteristics: $V_{DD} = 2.5V \pm 10\%$ or $3.3V \pm 10\%$; $T_A = -40^\circ C$ to $+105^\circ C$, unless noted.

Parameter	Symbol	Min.	Typ.	Max.	Units	Conditions
Supply Voltage	V_{DD}	2.25	—	3.63	V	Note 1
Supply Current	I_{DD}	—	50	—	mA	LVPECL, $f_{OUT} = 100$ MHz
		—	32	—		LVDS, $f_{OUT} = 100$ MHz
		—	40	—		HCSL, $f_{OUT} = 100$ MHz
		—	23	—		Output disabled (tri-state), $f_{OUT} = 100$ MHz
Standby Current	$I_{STDBY_}$	—	2.5	5	μA	Input pin = STDBY = Asserted ($V_{DD} = 3.3V$)
Frequency Stability	Δf	—	—	± 20	ppm	Includes frequency variations due to initial tolerance, temp., and power supply voltage
		—	—	± 25		
		—	—	± 50		
Aging	Δf	—	—	± 5	ppm	First year @ $25^\circ C$
		—	—	± 1		Per year after first year
Startup Time	t_{SU}	—	5.5	6	ms	From 90% V_{DD} to valid clock output, $T = +25^\circ C$, Note 2
Input Logic Levels	V_{IH}	$0.75 \times V_{DD}$	—	—	V	Input logic high
	V_{IL}	—	—	$0.25 \times V_{DD}$		Input logic low
Output Disable Time	t_{DA}	—	—	25	ns	Note 3
Output Enable Time	t_{EN}	—	—	6	ms	STDBY
		—	—	350	ns	OE
Enable Pull-Up Resistor	—	—	1.5	—	M Ω	Pull-up resistor on pin 1, Note 4
LVPECL (DSA12x2)						
Frequency	f_0	2.5	—	450	MHz	—
Output Logic Levels	V_{OH}	$V_{DD} - 1.145$	—	—	V	$R_L = 50\Omega$
	V_{OL}	—	—	$V_{DD} - 1.695$		
Peak-to-Peak Output Swing	V_{PP}	—	800	—	mV	Single-Ended
Output Transition Time	t_R	—	200	250	ps	20% to 80%, $R_L = 50\Omega$
	t_F	—	250	300		

DSA12X2/3/4

ELECTRICAL CHARACTERISTICS (CONTINUED)

Electrical Characteristics: $V_{DD} = 2.5V \pm 10\%$ or $3.3V \pm 10\%$; $T_A = -40^\circ C$ to $+105^\circ C$, unless noted.

Parameter	Symbol	Min.	Typ.	Max.	Units	Conditions
Output Duty Cycle	SYM	48	—	52	%	Differential
Period Jitter RMS	J_{PER}	—	2.0	—	ps	$f_0 = 156.25$ MHz, 10k cycles
Period Jitter Peak-to-Peak	J_{PTP}	—	20	—	ps	$f_0 = 156.25$ MHz, 10k cycles
Integrated Phase Noise (Random)	J_{PH}	—	0.65	—	ps _{RMS}	12 kHz to 20 MHz @156.25 MHz
LVDS Integrated Phase Noise (DSA12x3)						
Frequency	f_0	2.3	—	450	MHz	—
Output Offset Voltage	V_{OS}	1.15	1.25	1.35	V	R = 100Ω Differential
Peak-to-Peak Output Swing	V_{PP}	250	350	450	mV	Single-Ended
Output Transition Time	t_R	120	170	220	ps	20% to 80%, $R_L = 100\Omega$
	t_F					
Output Duty Cycle	SYM	48	—	52	%	Differential
Period Jitter RMS	J_{PER}	—	2.5	—	ps	$f_0 = 156.25$ MHz, 10k cycles
Period Jitter Peak-to-Peak	J_{PTP}	—	20	—	ps	$f_0 = 156.25$ MHz, 10k cycles
Period Jitter RMS	J_{PER}	—	3	—	ps	$f_0 = 156.25$ MHz, $T_A = -40^\circ C$ to $+125^\circ C$
Period Jitter Peak-to-Peak	J_{PTP}	—	25	—	ps	$f_0 = 156.25$ MHz, $T_A = -40^\circ C$ to $+125^\circ C$
Integrated Phase Noise (Random)	J_{PH}	—	0.65	—	ps _{RMS}	12 kHz to 20 MHz @156.25 MHz $T_A = -40^\circ C$ to $+105^\circ C$
		—	0.9	—		2 kHz to 20 MHz @156.25 MHz $T_A = -40^\circ C$ to $+125^\circ C$
HCSL (DSA12x4)						
Frequency	f_0	2.3	—	450	MHz	—
Output Logic Levels	V_{OH}	0.64	—	—	V	$R_L = 50\Omega$
	V_{OL}	—	—	0.1		
Peak-to-Peak Output Swing	V_{PP}	—	750	—	mV	Single-Ended
Output Transition Time	t_R	200	260	400	ps	20% to 80%, $R_L = 50\Omega$
	t_F	250	370	500		
Output Duty Cycle	SYM	48	—	52	%	Differential
Period Jitter RMS	J_{PER}	—	2	—	ps	$f_0 = 100.00$ MHz, 10k cycles
Period Jitter Peak-to-Peak	J_{PTP}	—	16	—	ps	$f_0 = 100.00$ MHz, 10k cycles
Integrated Phase Noise (Random)	J_{PH}	—	0.617	—	ps _{RMS}	12 kHz to 20 MHz @100 MHz
		—	0.460	—		100 kHz to 20 MHz @100 MHz
		—	0.212	—		1.875 MHz to 20 MHz @100 MHz

ELECTRICAL CHARACTERISTICS (CONTINUED)

Electrical Characteristics: $V_{DD} = 2.5V \pm 10\%$ or $3.3V \pm 10\%$; $T_A = -40^\circ C$ to $+105^\circ C$, unless noted.

Parameter	Symbol	Min.	Typ.	Max.	Units	Conditions
Phase Jitter	T_J	—	23	86	ps _{PP}	PCIe Gen 1.1, $T_J = D_J + 14.069 \times R_J$ (BER 10^{-12}), Note 5
	$J_{RMS-CCHF}$	—	2.230	3.1	ps _{RMS}	PCIe Gen 2.1, 1.5 MHz to Nyquist, Note 5
	$J_{RMS-CCLF}$	—	0.08	3.0	ps _{RMS}	PCIe Gen 2.1, 10 kHz to 1.5 MHz, Note 5
	J_{RMS-CC}	—	0.107	1.0	ps _{RMS}	PCIe Gen 3.0, Note 5
—		0.107	0.30	PCIe Gen 4.0, 16 GHz		
—		0.043	0.12	PCIe Gen 5.0, 32 GHz		

- Note 1:** V_{DD} pin should be filtered with a 0.1 μF capacitor.
2: t_{SU} is the time to 100 ppm stable output frequency after V_{DD} is applied and outputs are enabled.
3: t_{DA} : See the [Output Waveform](#) and the [Test Circuits](#) sections for more information.
4: Output is enabled if pad is floated (not connected).
5: Jitter limits established by Gen1.1, Gen 2.1, and Gen 3.0 PCIe standards.

TEMPERATURE SPECIFICATIONS [Note 1](#)

Parameters	Symbol	Min.	Typ.	Max.	Units	Conditions
Temperature Ranges						
Maximum Junction Temperature	T_J	—	—	+150	$^\circ C$	—
Storage Temperature Range	T_S	-55	—	+150	$^\circ C$	—
Lead Temperature	—	—	—	+260	$^\circ C$	Soldering, 40s

- Note 1:** The maximum allowable power dissipation is a function of ambient temperature, the maximum allowable junction temperature and the thermal resistance from junction to air (i.e., T_A , T_J , θ_{JA}). Exceeding the maximum allowable power dissipation will cause the device operating junction temperature to exceed the maximum +150 $^\circ C$ rating. Sustained junction temperatures above +150 $^\circ C$ can impact the device reliability.

DSA12X2/3/4

2.0 PIN DESCRIPTIONS

The descriptions of the pins are listed in [Table 2-1](#).

TABLE 2-1: DSA120X/1X/2X PIN FUNCTION TABLE

Pin Number	Pin Name	Description
1	OE/ $\overline{\text{STDBY}}$ /FS	Control pin: Output enable/standby/frequency select. External 10 k Ω pull up recommended when not actively driven.
2	NC	No connect.
3	GND	Power supply ground.
4	CLK+	Clock output +.
5	CLK-	Clock output -.
6	VDD	Power supply.

TABLE 2-2: DSA123X/4X/5X PIN FUNCTION TABLE

Pin Number	Pin Name	Description
1	NC	No connect.
2	OE/ $\overline{\text{STDBY}}$ /FS	Control pin: Output enable/standby/frequency select. External 10 k Ω pull up recommended when not actively driven.
3	GND	Power supply ground.
4	CLK+	Clock output +.
5	CLK-	Clock output -.
6	VDD	Power supply.

3.0 TERMINATION SCHEME

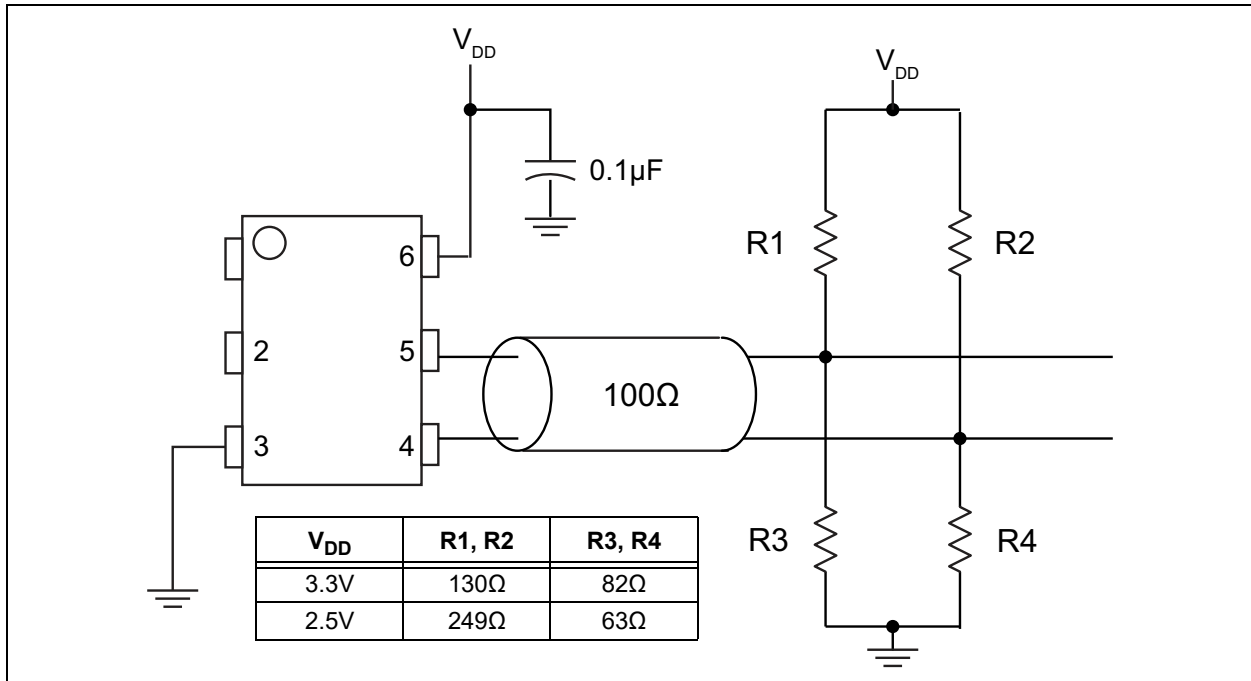

FIGURE 3-1: LVPECL Termination (DSA12x2).

In [Figure 3-1](#), Thevenin termination for 3.3V operation. Values will differ for $V_{DD} = 2.5V$.

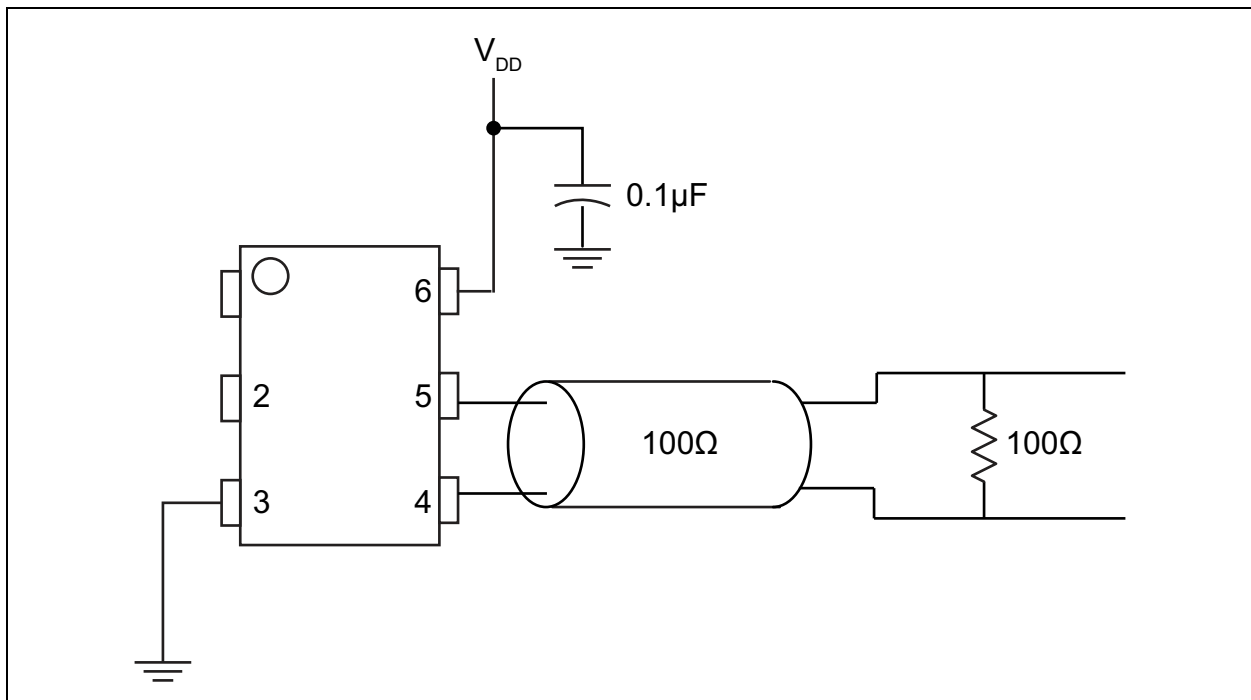

FIGURE 3-2: LVDS Termination (DSA12x3).

DSA12X2/3/4

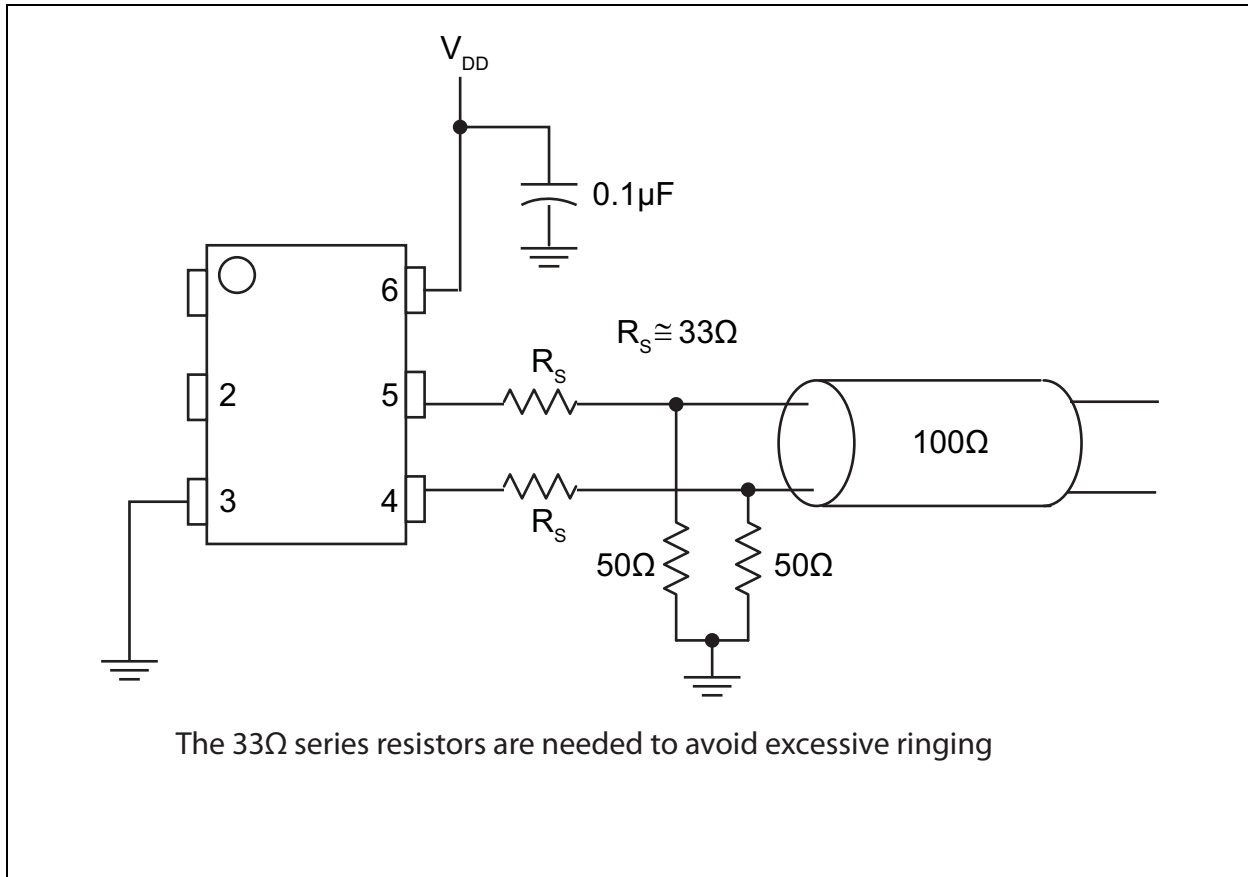

FIGURE 3-3: HCSSL Termination (DSA12x4).

4.0 OUTPUT WAVEFORM

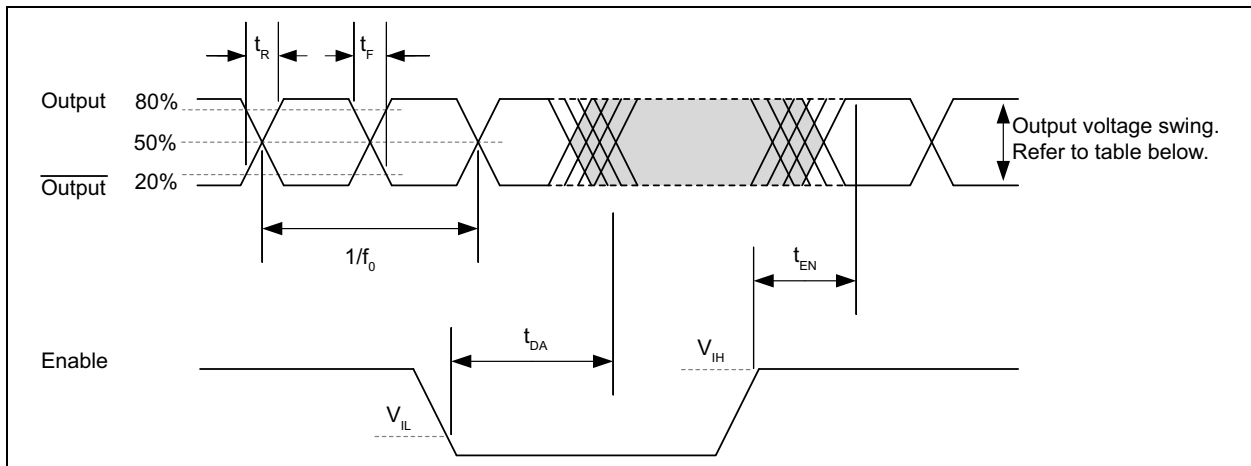

FIGURE 4-1: LVPECL, LVDS, and HCSL Output Waveform.

TABLE 4-1: OUTPUT VOLTAGE SWING BY LOGIC TYPE

Output Logic Protocol	Typical Peak-to-Peak Output Swing
LVPECL	830 mV
LVDS	350 mV
HCSL	675 mV

DSA12X2/3/4

5.0 TEST CIRCUITS

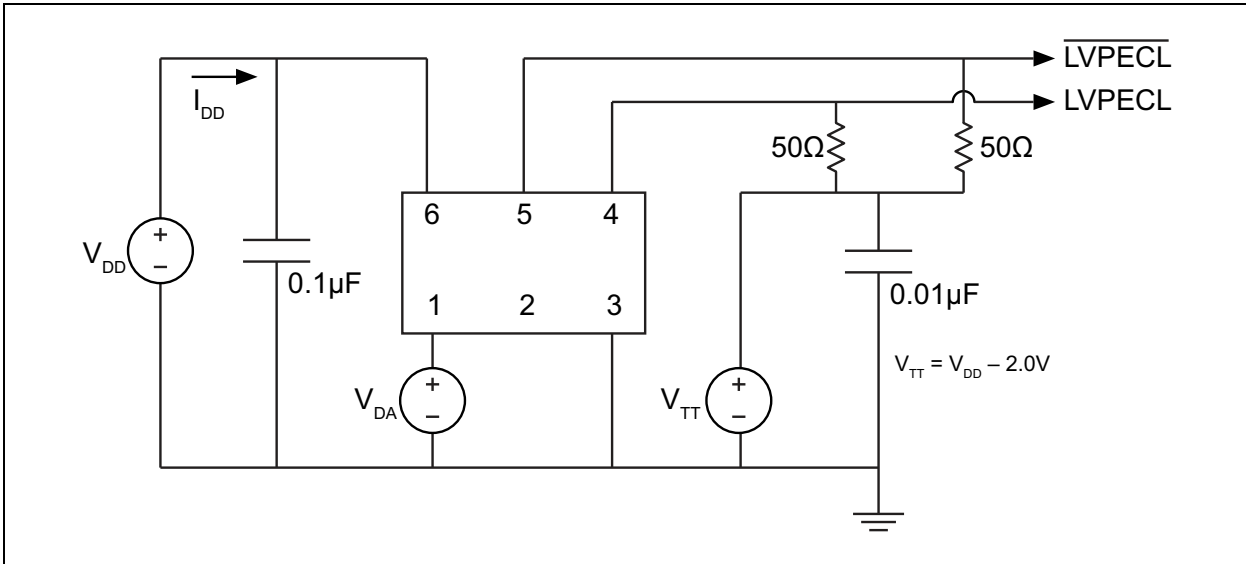

FIGURE 5-1: LVPECL Test Circuit.

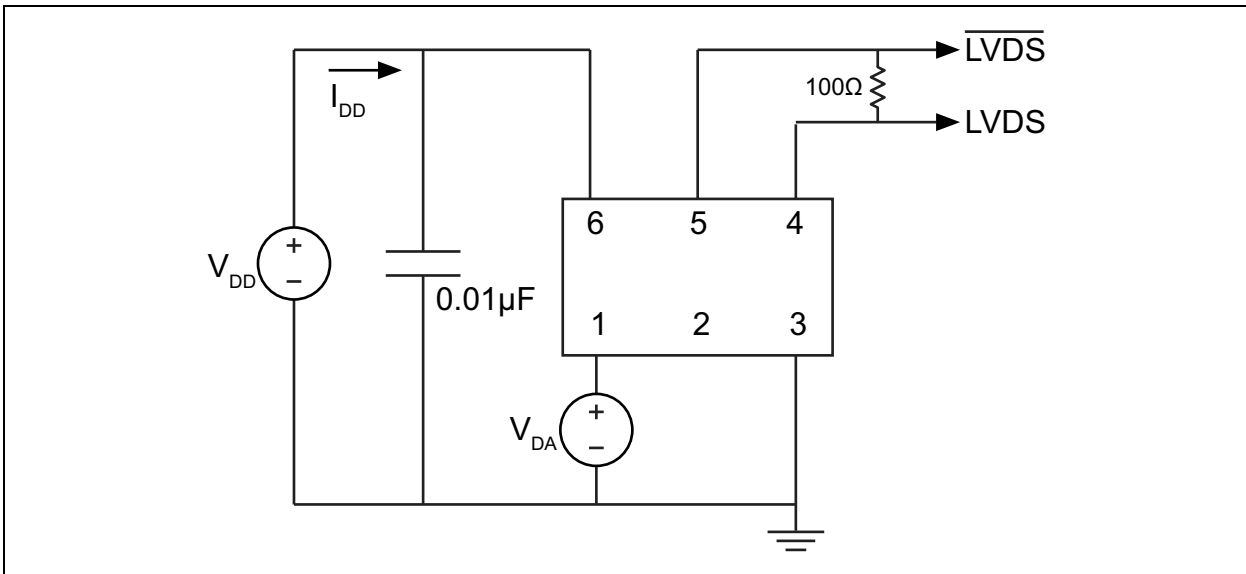

FIGURE 5-2: LVDS Test Circuit.

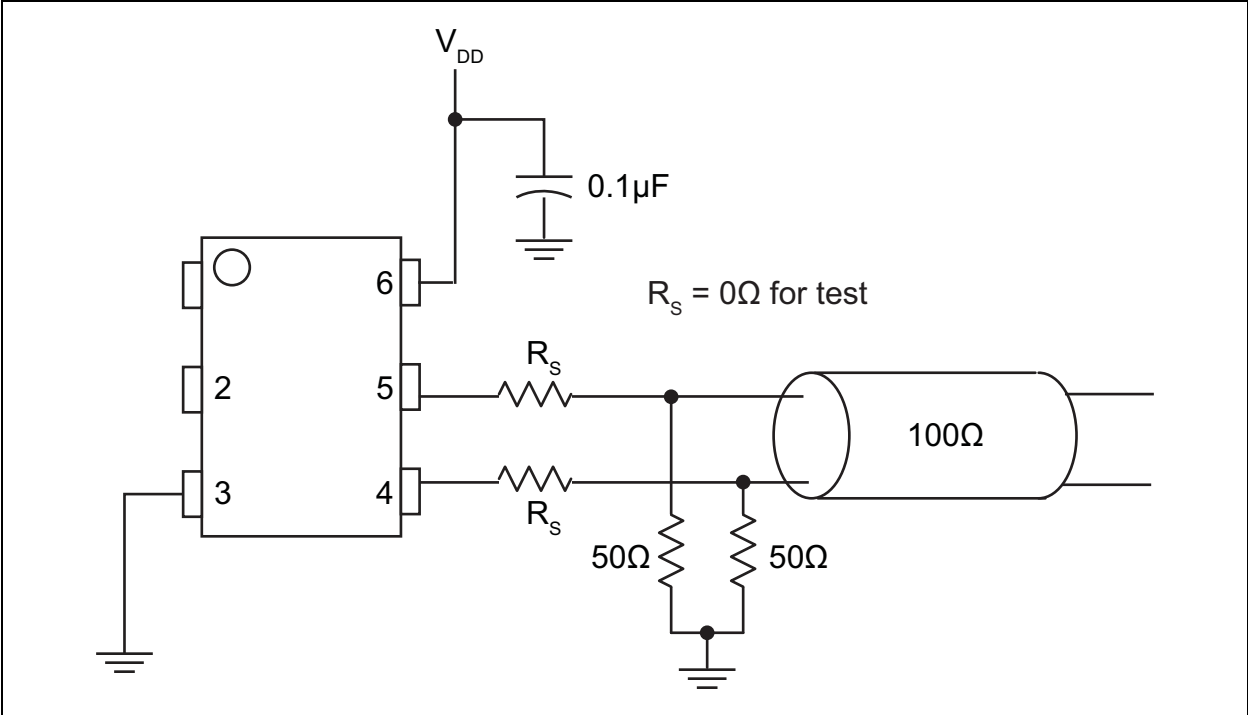

FIGURE 5-3: HCSL Test Circuit.

DSA12X2/3/4

6.0 SOLDER REFLOW PROFILE

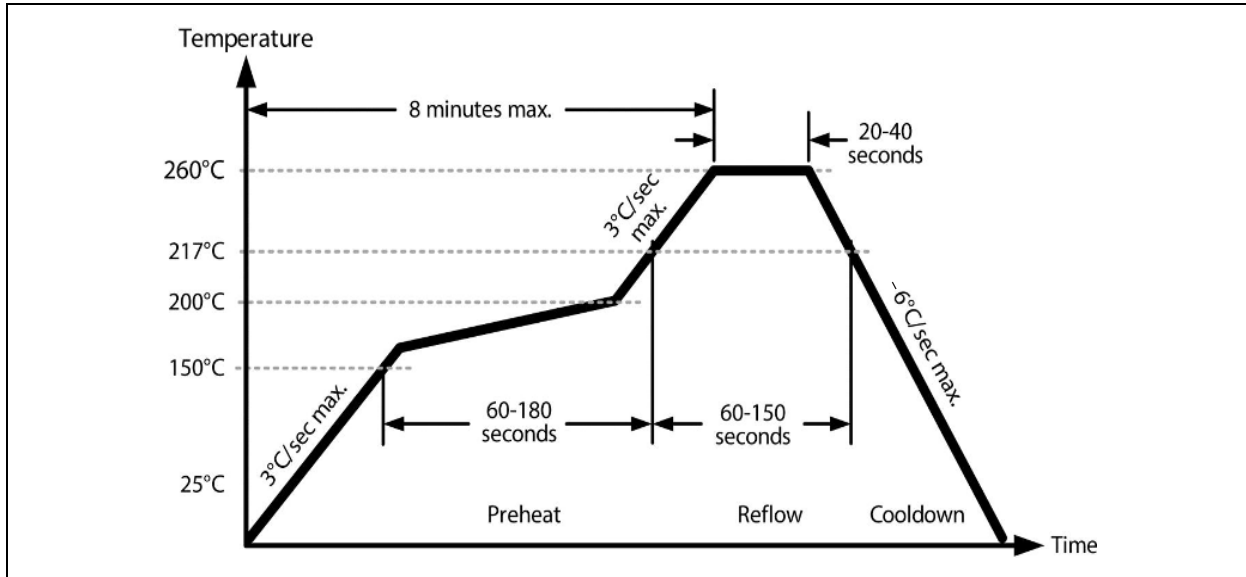

FIGURE 6-1: Solder Reflow Profile.

TABLE 6-1: SOLDER REFLOW

MSL 1 @ 260°C Refer to JSTD-020C	
Ramp-Up Rate (200°C to Peak Temp.)	3°C/sec. max.
Preheat Time 150°C to 200°C	60 to 180 sec.
Time Maintained above 217°C	60 to 150 sec.
Peak Temperature	255°C to 260°C
Time within 5°C of Actual Peak	20 to 40 sec.
Ramp-Down Rate	-6°C/sec. max.
Time 25°C to Peak Temperature	8 minutes max.

7.0 BOARD LAYOUT (RECOMMENDED)

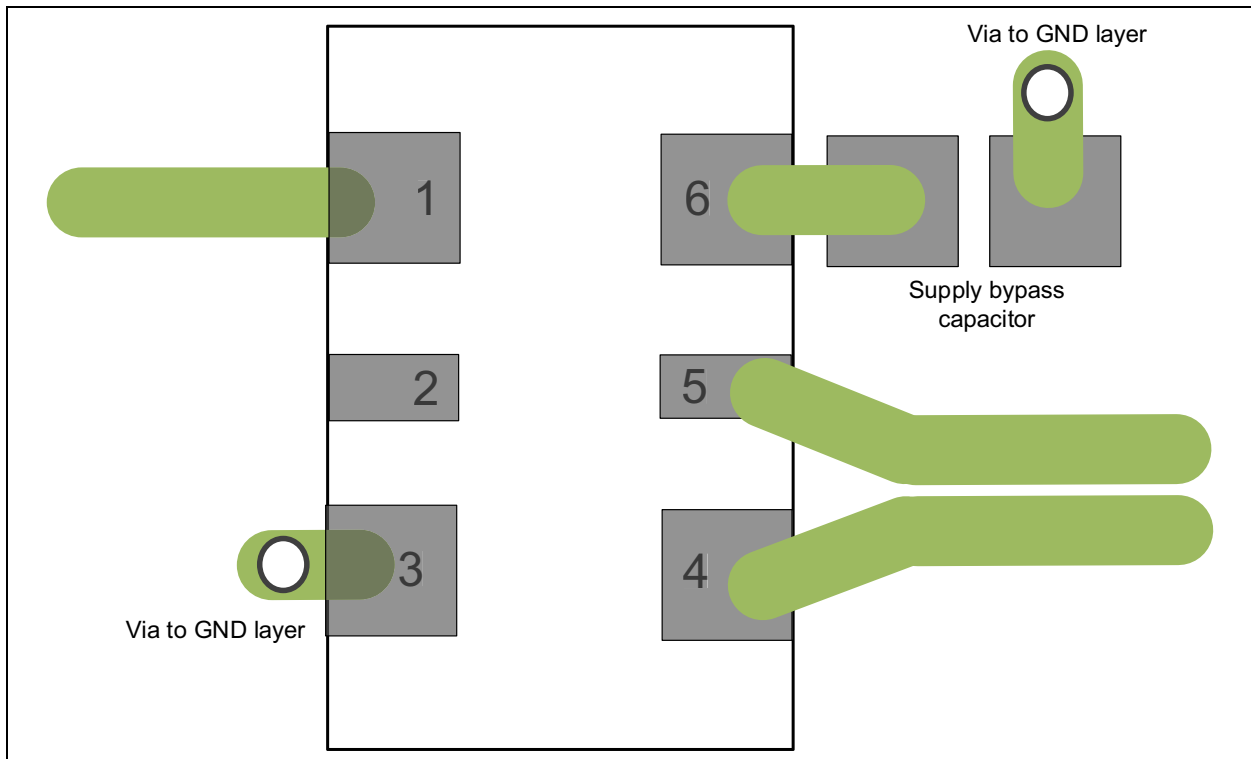

FIGURE 7-1: DSA12x2/3/4 Recommended Board Layout.

DSA12X2/3/4

8.0 PHASE NOISE

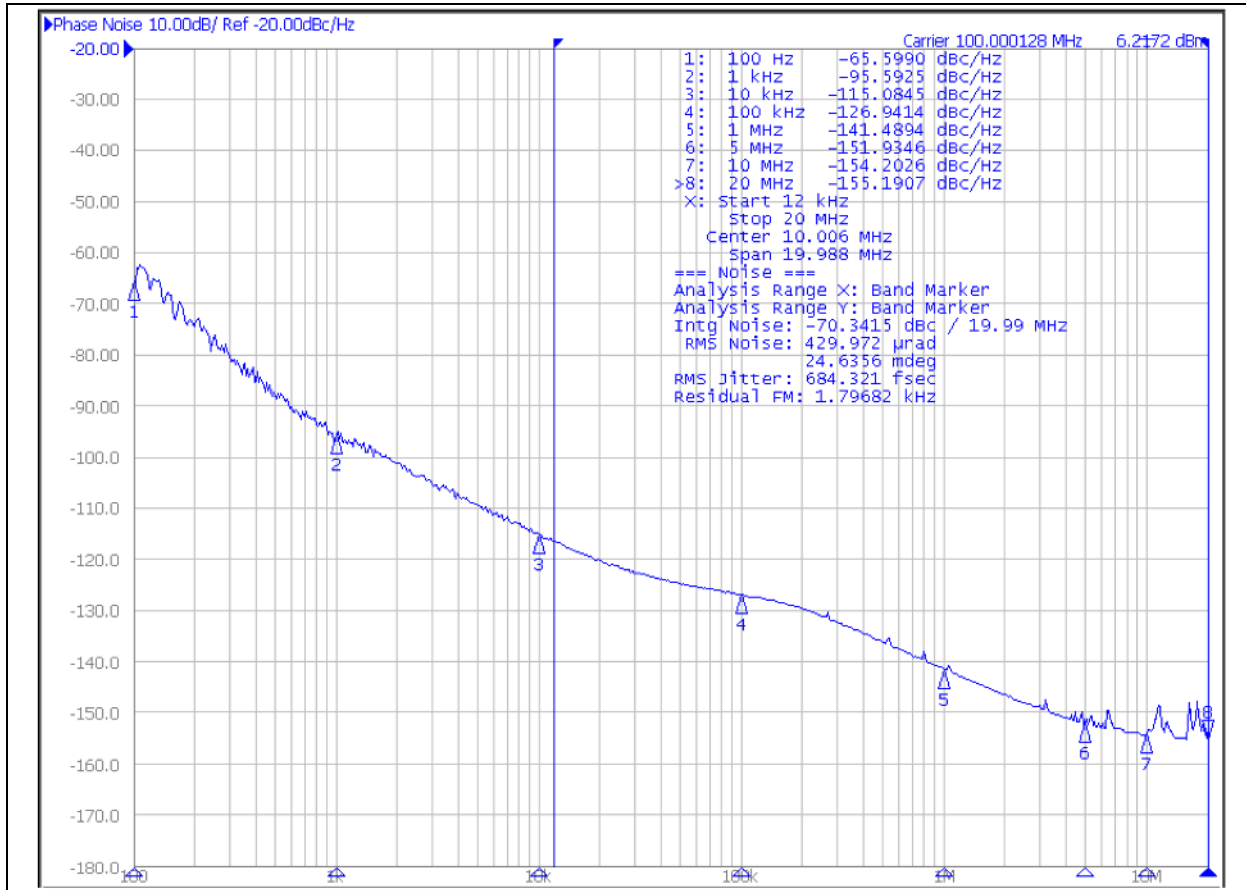

FIGURE 8-1: DSA12x4 Phase Noise at 100 MHz.

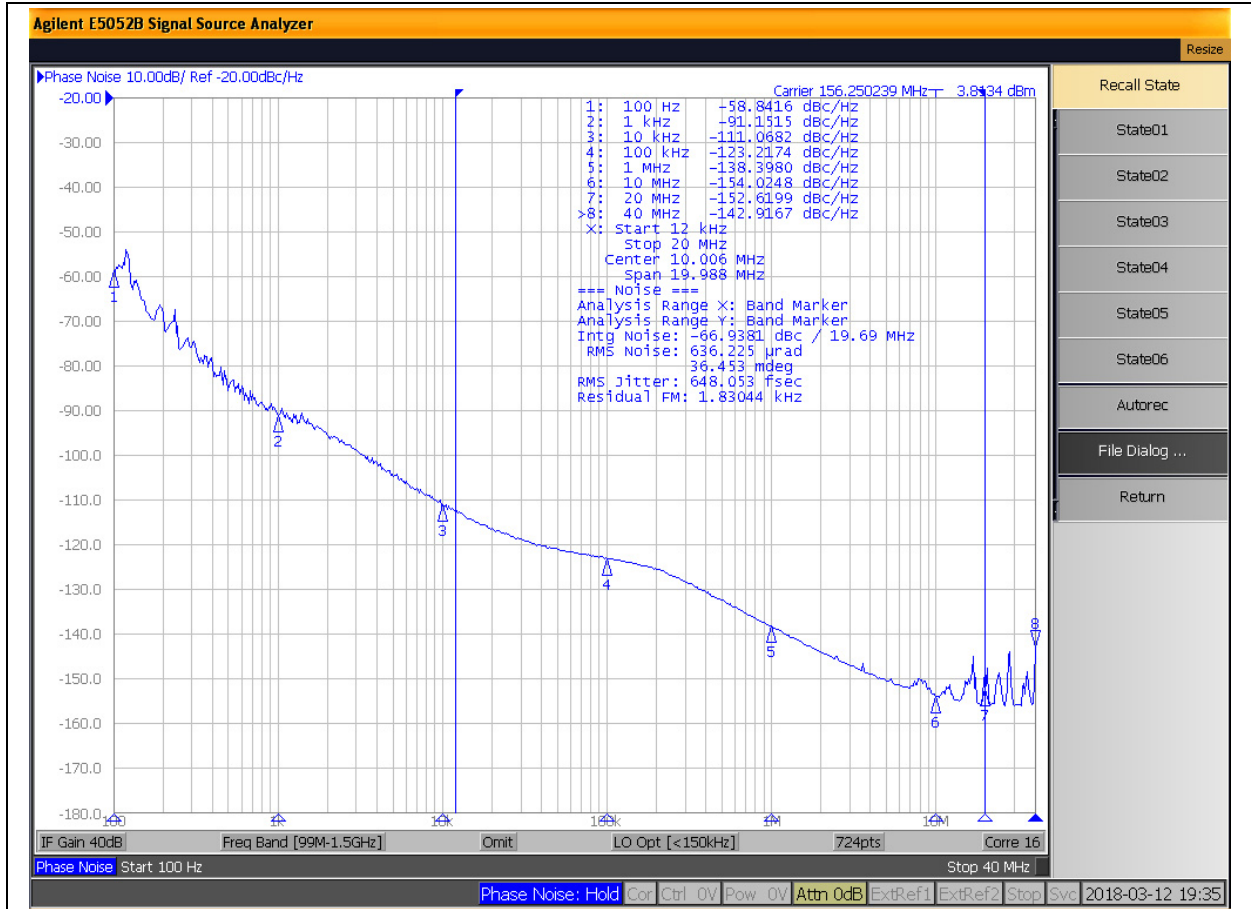

FIGURE 8-2: DSA12x2 Phase Noise at 156.25 MHz.

DSA12X2/3/4

9.0 PACKAGING INFORMATION

9.1 Package Marking Information

6-Pin CDFN/VDFN*

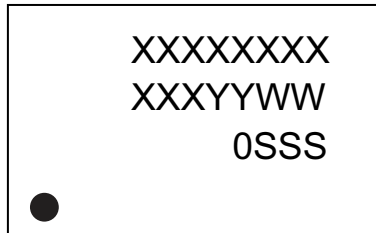

Example

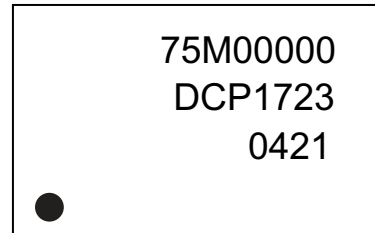

Legend:	XX...X	Product code or customer-specific information
	Y	Year code (last digit of calendar year)
	YY	Year code (last 2 digits of calendar year)
	WW	Week code (week of January 1 is week '01')
	SSS	Alphanumeric traceability code
	(e3)	Pb-free JEDEC® designator for Matte Tin (Sn)
	*	This package is Pb-free. The Pb-free JEDEC designator (e3) can be found on the outer packaging for this package.
	•, ▲, ▼	Pin one index is identified by a dot, delta up, or delta down (triangle mark).
Note:	In the event the full Microchip part number cannot be marked on one line, it will be carried over to the next line, thus limiting the number of available characters for customer-specific information. Package may or may not include the corporate logo.	
	Underbar (¯) and/or Overbar (¯) symbol may not be to scale.	

6-Lead VDFN 2.5 mm x 2.0 mm Package Outline and Recommended Land Pattern

6-Lead Very Thin Dual Flatpack No-Leads (J7A) - 2.5x2.0 mm Body [VDFN]

Note: For the most current package drawings, please see the Microchip Packaging Specification located at <http://www.microchip.com/packaging>

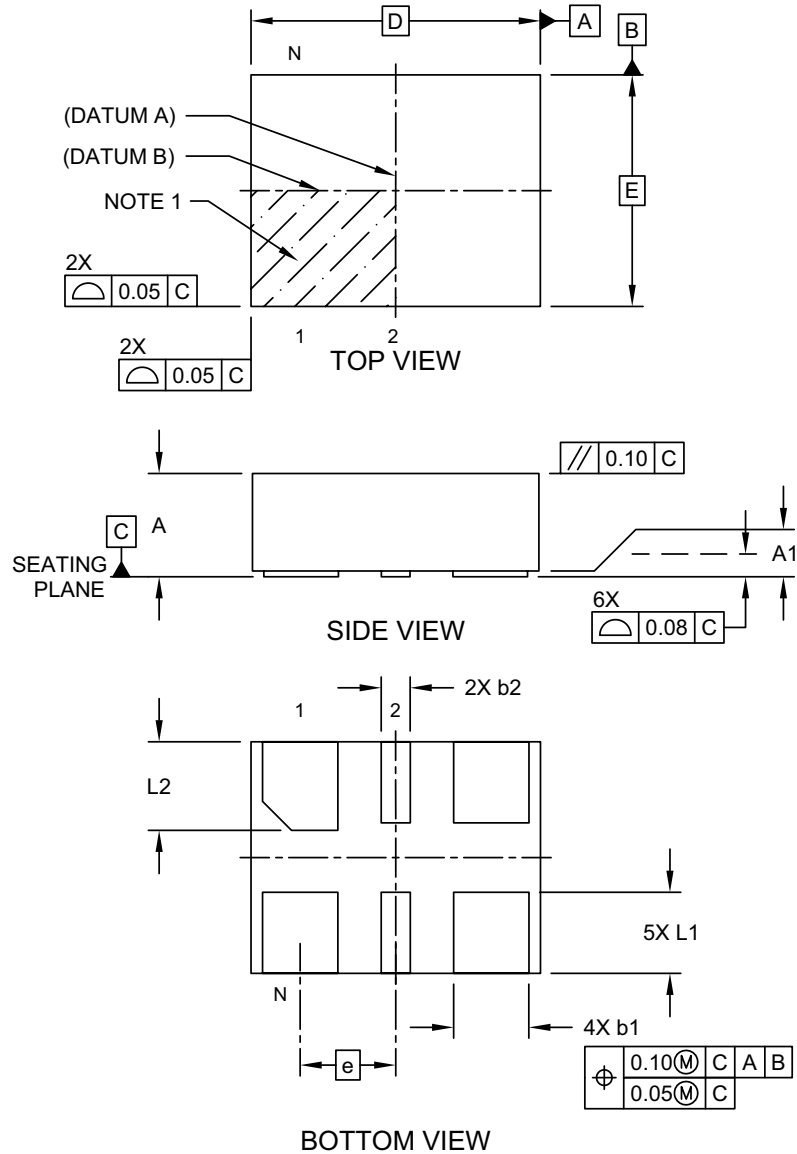

Microchip Technology Drawing C04-1005 Rev C Sheet 1 of 2

DSA12X2/3/4

6-Lead Very Thin Dual Flatpack No-Leads (J7A) - 2.5x2.0 mm Body [VDFN]

Note: For the most current package drawings, please see the Microchip Packaging Specification located at <http://www.microchip.com/packaging>

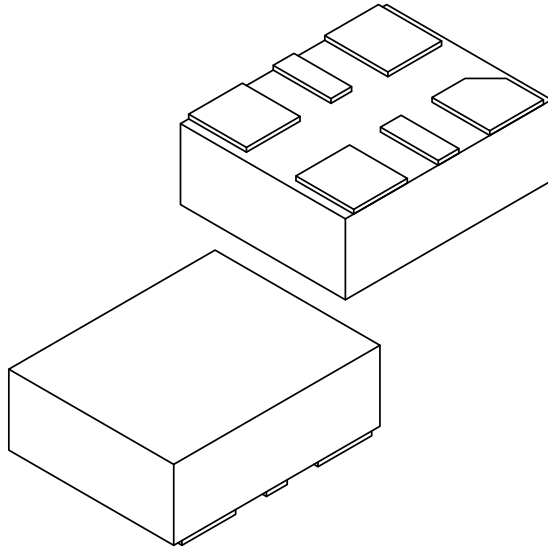

Dimension Limits	Units	MILLIMETERS		
		MIN	NOM	MAX
Number of Terminals	N	6		
Pitch	e	0.825 BSC		
Overall Height	A	0.80	0.85	0.90
Standoff	A1	0.00	0.02	0.05
Overall Length	D	2.50 BSC		
Overall Width	E	2.00 BSC		
Terminal Width	b1	0.60	0.65	0.70
Terminal Width	b2	0.20	0.25	0.30
Terminal Length	L1	0.60	0.70	0.80
Terminal Length	L2	0.665	0.765	0.865

Notes:

1. Pin 1 visual index feature may vary, but must be located within the hatched area.
2. Package is saw singulated
3. Dimensioning and tolerancing per ASME Y14.5M

BSC: Basic Dimension. Theoretically exact value shown without tolerances.

REF: Reference Dimension, usually without tolerance, for information purposes only.

Microchip Technology Drawing C04-1005 Rev C Sheet 2 of 2

6-Lead Very Thin Dual Flatpack No-Leads (J7A) - 2.5x2.0 mm Body [VDFN]

Note: For the most current package drawings, please see the Microchip Packaging Specification located at <http://www.microchip.com/packaging>

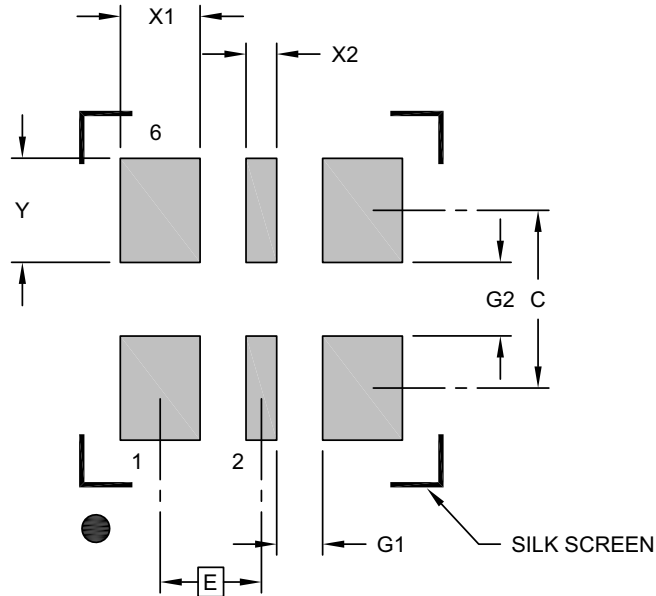

RECOMMENDED LAND PATTERN

Dimension Limits	Units	MILLIMETERS		
		MIN	NOM	MAX
Contact Pitch	E	0.825 BSC		
Contact Pad Width (X4)	X1			0.65
Contact Pad Width (X2)	X2			0.25
Contact Pad Length (X6)	Y			0.85
Contact Pad Spacing	C		1.45	
Space Between Contacts (X4)	G1	0.38		
Space Between Contacts (X3)	G2	0.60		

Notes:

- Dimensioning and tolerancing per ASME Y14.5M
BSC: Basic Dimension. Theoretically exact value shown without tolerances.
- For best soldering results, thermal vias, if used, should be filled or tented to avoid solder loss during reflow process

Microchip Technology Drawing C04-3005 Rev C

DSA12X2/3/4

6-Lead VDFN 3.2 mm x 2.5 mm Package Outline and Recommended Land Pattern

6-Lead Very Thin Plastic Dual Flatpack No-Lead (H5A) - 3.2x2.5 mm Body [VDFN]

Note: For the most current package drawings, please see the Microchip Packaging Specification located at <http://www.microchip.com/packaging>

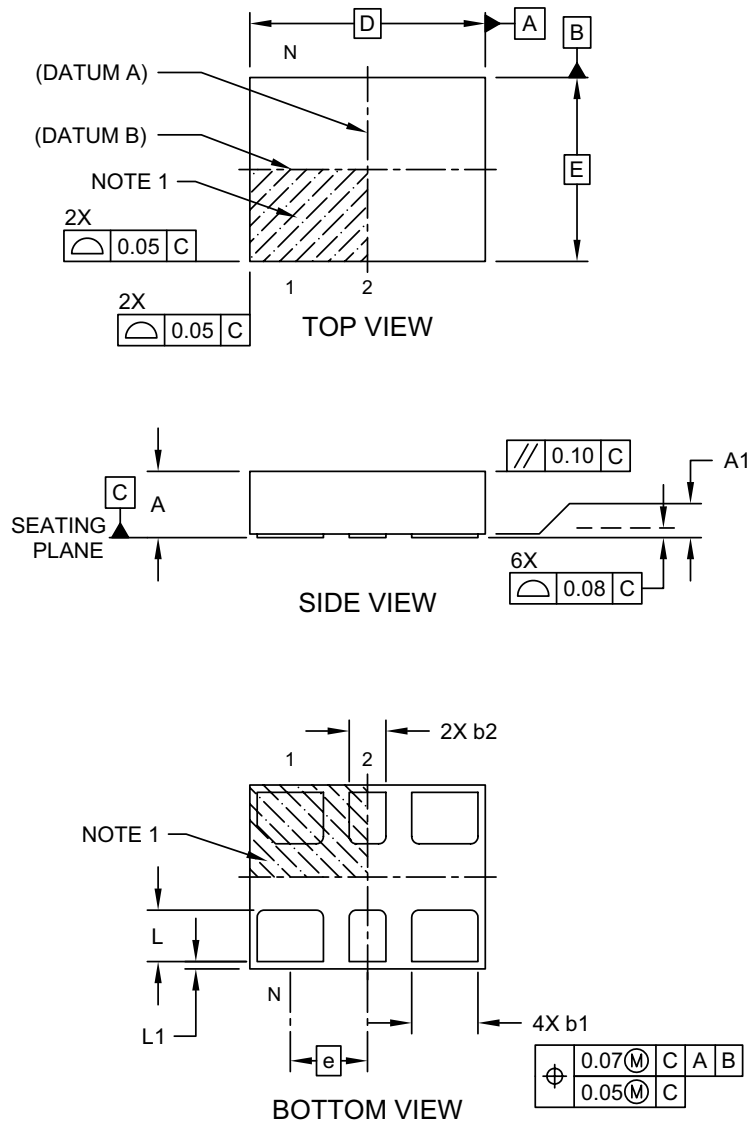

Microchip Technology Drawing C04-1007A Sheet 1 of 2

6-Lead Very Thin Plastic Dual Flatpack No-Lead (H5A) - 3.2x2.5 mm Body [VDFN]

Note: For the most current package drawings, please see the Microchip Packaging Specification located at <http://www.microchip.com/packaging>

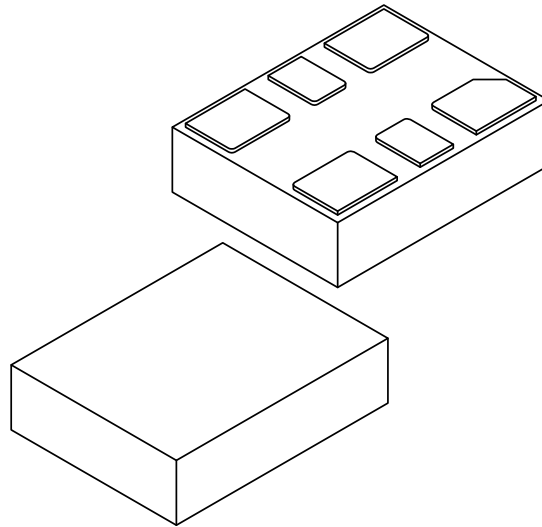

Dimension Limits	Units	MILLIMETERS		
		MIN	NOM	MAX
Number of Terminals	N	6		
Pitch	e	1.05 BSC		
Overall Height	A	0.80	0.85	0.90
Standoff	A1	0.00	0.02	0.05
Overall Length	D	3.20 BSC		
Overall Width	E	2.50 BSC		
Terminal Width	b1	0.85	0.90	0.95
Terminal Width	b2	0.45	0.50	0.55
Terminal Length	L	0.65	0.70	0.75
Terminal Pullback	L1	0.10 REF		

Notes:

1. Pin 1 visual index feature may vary, but must be located within the hatched area.
2. Package is saw singulated
3. Dimensioning and tolerancing per ASME Y14.5M
 - BSC: Basic Dimension. Theoretically exact value shown without tolerances.
 - REF: Reference Dimension, usually without tolerance, for information purposes only.

Microchip Technology Drawing C04-1007A Sheet 2 of 2

6-Lead Very Thin Plastic Dual Flatpack No-Lead (H5A) - 3.2x2.5 mm Body [VDFN]

Note: For the most current package drawings, please see the Microchip Packaging Specification located at <http://www.microchip.com/packaging>

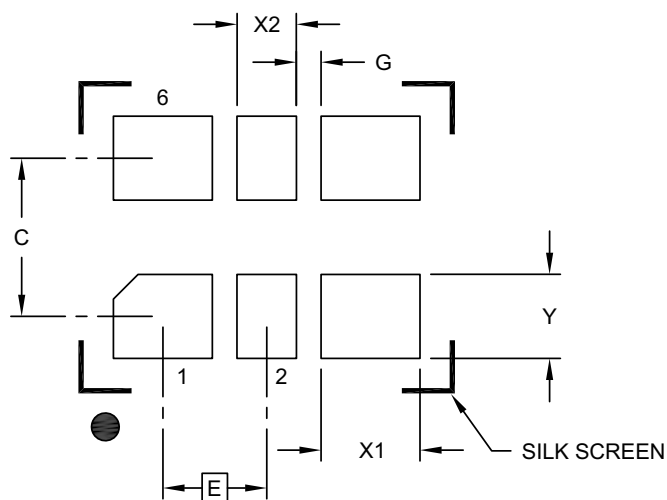

RECOMMENDED LAND PATTERN

Dimension	Units	MILLIMETERS		
		MIN	NOM	MAX
Contact Pitch	E	1.05 BSC		
Contact Pad Spacing	C		1.60	
Contact Pad Width (X4)	X1			1.00
Contact Pad Width (X2)	X2			0.60
Contact Pad Length (X6)	Y			0.85
Space Between Contacts (X4)	G1	0.25		

Notes:

1. Dimensioning and tolerancing per ASME Y14.5M

BSC: Basic Dimension. Theoretically exact value shown without tolerances.

Microchip Technology Drawing C04-3007A

6-Lead CDFN 5.0 mm x 3.2 mm Package Outline and Recommended Land Pattern

TITLE

6 LEAD CDFN 5.0x3.2mm COL PACKAGE OUTLINE & RECOMMENDED LAND PATTERN

DRAWING #	CDFN5032-6LD-PL-1	UNIT	MM
-----------	-------------------	------	----

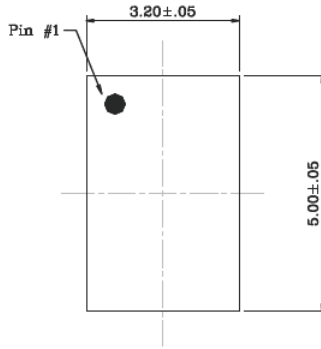

Top View

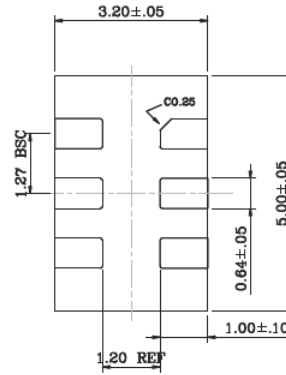

Bottom View



Side View

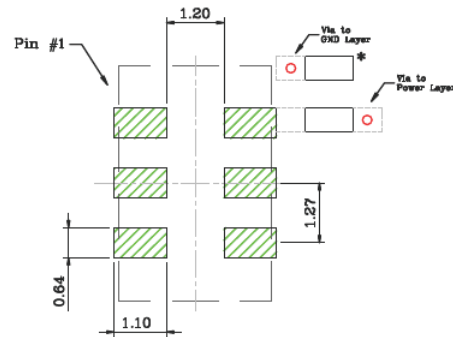

Recommended Land Pattern

NOTE:

1. * Power Supply Decoupling Capacitor is required in Recommended Land Pattern.
2. Green shaded rectangles in Recommended Land Pattern are solder stencil opening.
3. Red circles in Recommended Land Pattern are thermal VIA.

Note: For the most current package drawings, please see the Microchip Packaging Specification located at <http://www.microchip.com/packaging>.

DSA12X2/3/4

6-Lead VDFN 7.0 mm x 5.0 mm Package Outline and Recommended Land Pattern

6-Lead Very Thin Dual Flatpack, No Lead Package (HPA) - 7x5 mm Body [VDFN]

Note: For the most current package drawings, please see the Microchip Packaging Specification located at <http://www.microchip.com/packaging>

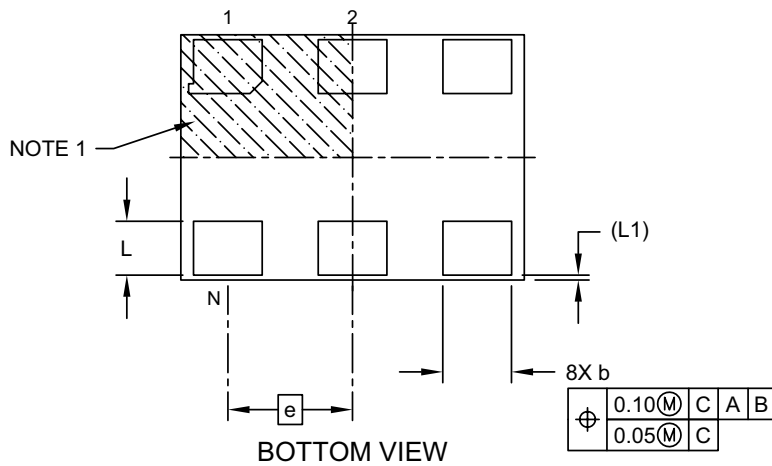
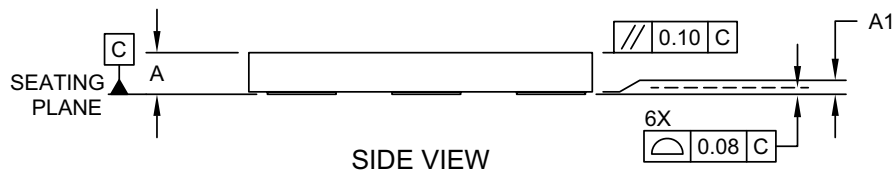
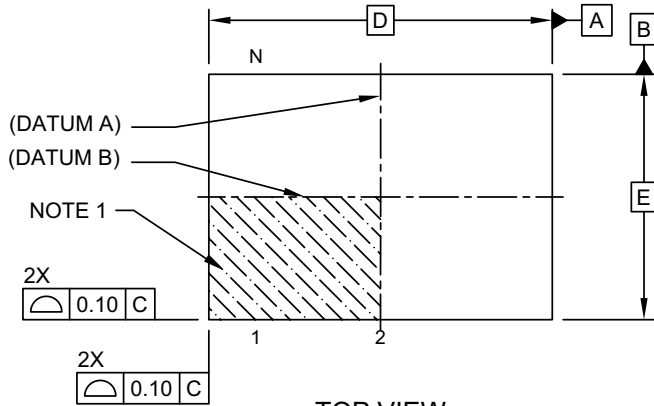

Microchip Technology Drawing C04-1227 Rev A Sheet 1 of 2

6-Lead Very Thin Dual Flatpack, No Lead Package (HPA) - 7x5 mm Body [VDFN]

Note: For the most current package drawings, please see the Microchip Packaging Specification located at <http://www.microchip.com/packaging>

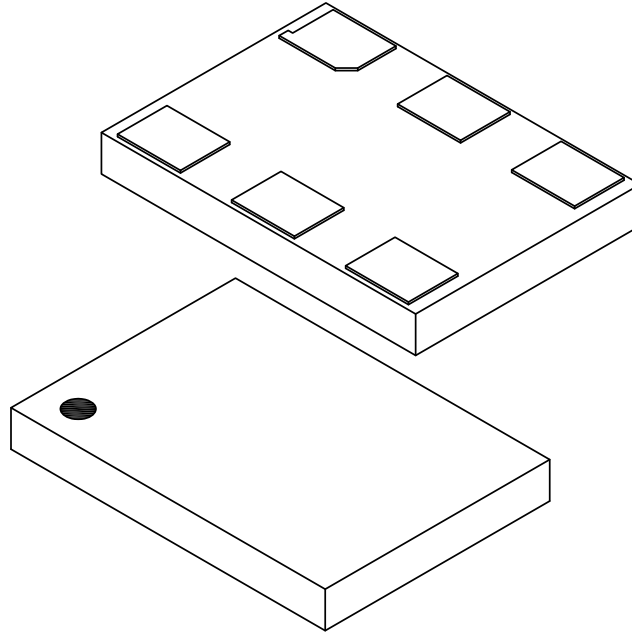

Dimension Limits	Units	MILLIMETERS		
		MIN	NOM	MAX
Number of Terminals	N	6		
Pitch	e	2.54 BSC		
Overall Height	A	0.80	0.85	0.90
Standoff	A1	0.00	0.02	0.05
Overall Length	D	7.00 BSC		
Overall Width	E	5.00 BSC		
Terminal Width	b	1.30	1.40	1.50
Terminal Length	L	1.00	1.10	1.20
Pullback	L1	0.10 REF		

Notes:

- Pin 1 visual index feature may vary, but must be located within the hatched area.
- Package is saw singulated
- Dimensioning and tolerancing per ASME Y14.5M
 - BSC: Basic Dimension. Theoretically exact value shown without tolerances.
 - REF: Reference Dimension, usually without tolerance, for information purposes only.

Microchip Technology Drawing C04-1227 Rev A Sheet 2 of 2

6-Lead Very Thin Dual Flatpack, No Lead Package (HPA) - 7x5 mm Body [VDFN]

Note: For the most current package drawings, please see the Microchip Packaging Specification located at <http://www.microchip.com/packaging>

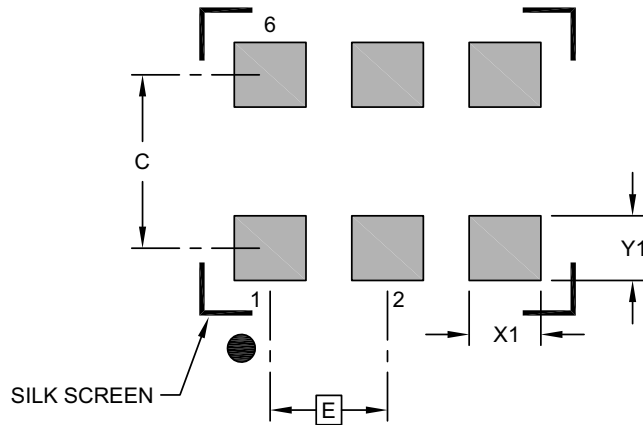

RECOMMENDED LAND PATTERN

Dimension Limits	Units	MILLIMETERS		
		MIN	NOM	MAX
Contact Pitch	E	2.54 BSC		
Contact Pad Spacing	C		3.90	
Contact Pad Width (X6)	X1			1.55
Contact Pad Length (X6)	Y1			1.40

Notes:

- Dimensioning and tolerancing per ASME Y14.5M
BSC: Basic Dimension. Theoretically exact value shown without tolerances.
- For best soldering results, thermal vias, if used, should be filled or tented to avoid solder loss during reflow process

Microchip Technology Drawing C04-3227 Rev A

APPENDIX A: REVISION HISTORY

Revision A (June 2020)

- Initial release of DSA12x2/3/4 as Microchip data sheet DS20006378A.

Revision B (March 2021)

- Updated Phase Jitter maximum values for J_{RMS-CC} in the [Electrical Characteristics](#) table and added a sixth note.
- Updated package drawing for [6-Lead VDFN 2.5 mm x 2.0 mm Package Outline and Recommended Land Pattern](#).
- Updated [Figure 3-1](#).

Revision C (March 2021)

- Removed Note 6 from the [Electrical Characteristics](#) table.

DSA12X2/3/4

NOTES:

PRODUCT IDENTIFICATION SYSTEM

To order or obtain information, e.g., on pricing or delivery, contact your local Microchip representative or sales office.

PART NO.	X	X	X	X	X	-XXXXXXXX	X	XXX																																																																									
Device	Control Pin	Output Format	Package	Temperature	Freq. Stability	Output Frequency	Media Type	Automotive Suffix																																																																									
<p>Device: DSA12: High Performance Differential MEMS Oscillators for Automotive</p> <p>Control Pin:</p> <table style="width: 100%;"> <tr><td>0</td><td>=</td><td>Pin 1 <u>STDBY</u> with Pull-up</td></tr> <tr><td>1</td><td>=</td><td>Pin 1 Frequency Select with Pull-up</td></tr> <tr><td>2</td><td>=</td><td>Pin 1 <u>OE</u> with Pull-up</td></tr> <tr><td>3</td><td>=</td><td>Pin 2 <u>STDBY</u> with Pull-up</td></tr> <tr><td>4</td><td>=</td><td>Pin 2 Frequency Select with Pull-up</td></tr> <tr><td>5</td><td>=</td><td>Pin 2 OE with Pull-up</td></tr> </table> <p>Output Format:</p> <table style="width: 100%;"> <tr><td>2</td><td>=</td><td>LVPECL</td></tr> <tr><td>3</td><td>=</td><td>LVDS</td></tr> <tr><td>4</td><td>=</td><td>HCSL</td></tr> </table> <p>Package:</p> <table style="width: 100%;"> <tr><td>N</td><td>=</td><td>7 mm x 5 mm 6-Lead VDFN</td></tr> <tr><td>B</td><td>=</td><td>5 mm x 3.2 mm 6-Lead CDFN</td></tr> <tr><td>C</td><td>=</td><td>3.2 mm x 2.5 mm 6-Lead VDFN</td></tr> <tr><td>D</td><td>=</td><td>2.5 mm x 2 mm 6-Lead VDFN</td></tr> </table> <p>Temperature:</p> <table style="width: 100%;"> <tr><td>A</td><td>=</td><td>-40°C to +125°C (Grade 1)</td></tr> <tr><td>L</td><td>=</td><td>-40°C to +105°C (Grade 2)</td></tr> <tr><td>I</td><td>=</td><td>-40°C to +85°C (Grade 3)</td></tr> </table> <p>Frequency Stability:</p> <table style="width: 100%;"> <tr><td>1</td><td>=</td><td>±50 ppm</td></tr> <tr><td>2</td><td>=</td><td>±25 ppm</td></tr> <tr><td>3</td><td>=</td><td>±20 ppm</td></tr> </table> <p>Output Frequency:</p> <table style="width: 100%;"> <tr><td>xMxxxxx=</td><td><10 MHz</td></tr> <tr><td>xxMxxxxx=</td><td><100 MHz</td></tr> <tr><td>xxxMxxxx=</td><td>>100 MHz</td></tr> <tr><td>CCCCC=</td><td>with Frequency Select</td></tr> <tr><td>PROG =</td><td>TimeFlash</td></tr> </table> <p>Media Type:</p> <table style="width: 100%;"> <tr><td><blank>=</td><td>Bulk</td></tr> <tr><td>T</td><td>= 1,000/Reel</td></tr> <tr><td>B</td><td>= 3,000/Reel</td></tr> </table> <p>Automotive Suffix: VXX = Automotive Suffix in which "XX" is assigned by Microchip. Default value is "AO" for standard automotive part</p>	0	=	Pin 1 <u>STDBY</u> with Pull-up	1	=	Pin 1 Frequency Select with Pull-up	2	=	Pin 1 <u>OE</u> with Pull-up	3	=	Pin 2 <u>STDBY</u> with Pull-up	4	=	Pin 2 Frequency Select with Pull-up	5	=	Pin 2 OE with Pull-up	2	=	LVPECL	3	=	LVDS	4	=	HCSL	N	=	7 mm x 5 mm 6-Lead VDFN	B	=	5 mm x 3.2 mm 6-Lead CDFN	C	=	3.2 mm x 2.5 mm 6-Lead VDFN	D	=	2.5 mm x 2 mm 6-Lead VDFN	A	=	-40°C to +125°C (Grade 1)	L	=	-40°C to +105°C (Grade 2)	I	=	-40°C to +85°C (Grade 3)	1	=	±50 ppm	2	=	±25 ppm	3	=	±20 ppm	xMxxxxx=	<10 MHz	xxMxxxxx=	<100 MHz	xxxMxxxx=	>100 MHz	CCCCC=	with Frequency Select	PROG =	TimeFlash	<blank>=	Bulk	T	= 1,000/Reel	B	= 3,000/Reel	<p>Examples:</p> <p>a) DSA1202NI1-25M0000TVAO: Pin 1 <u>STDBY</u> with Pull-up, LVPECL Output, 7x5 VDFN, -20°C to +85°C, ±50 ppm, 25 MHz Output Frequency, 1,000/Reel, Standard Automotive</p> <p>b) DSA1243CL3-C0013VAO: Pin 2 Frequency Select with Pull-up, LVDS Output, 3.2x2.5 VDFN, -40°C to +105°C, ±20 ppm, Multiple Output Frequency, Bulk, Standard Automotive</p> <p>c) DSA124BI2-19M5000BVAO: Pin 1 OE with Pull-up, HCSL Output, 5x3.2 CDFN, -40°C to +85°C, ±25 ppm, 19.5 MHz Output Frequency, 3,000/Reel, Standard Automotive</p> <p>d) DSA1232DL3-55M82000TVAO: Pin 2 <u>STDBY</u> with Pull-up, LVPECL Output, 2.5x2 VDFN, -40°C to +105°C, ±20 ppm, 55.82 MHz Output Frequency, 1,000/Reel, Standard Automotive</p> <p>e) DSA1213NI1-C0014BVAO: Pin 1 Frequency Select with Pull-up, LVDS Output, 7x5 VDFN, -40°C to +85°C, ±50 ppm, Multiple Output Frequency, 3,000/Reel, Standard Automotive</p> <p>Note 1: Tape and Reel identifier only appears in the catalog part number description. This identifier is used for ordering purposes and is not printed on the device package. Check with your Microchip Sales Office for package availability with the Tape and Reel option.</p>							
0	=	Pin 1 <u>STDBY</u> with Pull-up																																																																															
1	=	Pin 1 Frequency Select with Pull-up																																																																															
2	=	Pin 1 <u>OE</u> with Pull-up																																																																															
3	=	Pin 2 <u>STDBY</u> with Pull-up																																																																															
4	=	Pin 2 Frequency Select with Pull-up																																																																															
5	=	Pin 2 OE with Pull-up																																																																															
2	=	LVPECL																																																																															
3	=	LVDS																																																																															
4	=	HCSL																																																																															
N	=	7 mm x 5 mm 6-Lead VDFN																																																																															
B	=	5 mm x 3.2 mm 6-Lead CDFN																																																																															
C	=	3.2 mm x 2.5 mm 6-Lead VDFN																																																																															
D	=	2.5 mm x 2 mm 6-Lead VDFN																																																																															
A	=	-40°C to +125°C (Grade 1)																																																																															
L	=	-40°C to +105°C (Grade 2)																																																																															
I	=	-40°C to +85°C (Grade 3)																																																																															
1	=	±50 ppm																																																																															
2	=	±25 ppm																																																																															
3	=	±20 ppm																																																																															
xMxxxxx=	<10 MHz																																																																																
xxMxxxxx=	<100 MHz																																																																																
xxxMxxxx=	>100 MHz																																																																																
CCCCC=	with Frequency Select																																																																																
PROG =	TimeFlash																																																																																
<blank>=	Bulk																																																																																
T	= 1,000/Reel																																																																																
B	= 3,000/Reel																																																																																

Please visit the [Microchip ClockWorks Configurator®](http://clockworks.microchip.com/timing) website to configure the part number for customized frequency select settings.

<http://clockworks.microchip.com/timing>

DSA12X2/3/4

NOTES:

Note the following details of the code protection feature on Microchip devices:

- Microchip products meet the specifications contained in their particular Microchip Data Sheet.
- Microchip believes that its family of products is secure when used in the intended manner and under normal conditions.
- There are dishonest and possibly illegal methods being used in attempts to breach the code protection features of the Microchip devices. We believe that these methods require using the Microchip products in a manner outside the operating specifications contained in Microchip's Data Sheets. Attempts to breach these code protection features, most likely, cannot be accomplished without violating Microchip's intellectual property rights.
- Microchip is willing to work with any customer who is concerned about the integrity of its code.
- Neither Microchip nor any other semiconductor manufacturer can guarantee the security of its code. Code protection does not mean that we are guaranteeing the product is "unbreakable." Code protection is constantly evolving. We at Microchip are committed to continuously improving the code protection features of our products. Attempts to break Microchip's code protection feature may be a violation of the Digital Millennium Copyright Act. If such acts allow unauthorized access to your software or other copyrighted work, you may have a right to sue for relief under that Act.

Information contained in this publication is provided for the sole purpose of designing with and using Microchip products. Information regarding device applications and the like is provided only for your convenience and may be superseded by updates. It is your responsibility to ensure that your application meets with your specifications.

THIS INFORMATION IS PROVIDED BY MICROCHIP "AS IS". MICROCHIP MAKES NO REPRESENTATIONS OR WARRANTIES OF ANY KIND WHETHER EXPRESS OR IMPLIED, WRITTEN OR ORAL, STATUTORY OR OTHERWISE, RELATED TO THE INFORMATION INCLUDING BUT NOT LIMITED TO ANY IMPLIED WARRANTIES OF NON-INFRINGEMENT, MERCHANTABILITY, AND FITNESS FOR A PARTICULAR PURPOSE OR WARRANTIES RELATED TO ITS CONDITION, QUALITY, OR PERFORMANCE.

IN NO EVENT WILL MICROCHIP BE LIABLE FOR ANY INDIRECT, SPECIAL, PUNITIVE, INCIDENTAL OR CONSEQUENTIAL LOSS, DAMAGE, COST OR EXPENSE OF ANY KIND WHATSOEVER RELATED TO THE INFORMATION OR ITS USE, HOWEVER CAUSED, EVEN IF MICROCHIP HAS BEEN ADVISED OF THE POSSIBILITY OR THE DAMAGES ARE FORESEEABLE. TO THE FULLEST EXTENT ALLOWED BY LAW, MICROCHIP'S TOTAL LIABILITY ON ALL CLAIMS IN ANY WAY RELATED TO THE INFORMATION OR ITS USE WILL NOT EXCEED THE AMOUNT OF FEES, IF ANY, THAT YOU HAVE PAID DIRECTLY TO MICROCHIP FOR THE INFORMATION. Use of Microchip devices in life support and/or safety applications is entirely at the buyer's risk, and the buyer agrees to defend, indemnify and hold harmless Microchip from any and all damages, claims, suits, or expenses resulting from such use. No licenses are conveyed, implicitly or otherwise, under any Microchip intellectual property rights unless otherwise stated.

Trademarks

The Microchip name and logo, the Microchip logo, Adaptec, AnyRate, AVR, AVR logo, AVR Freaks, BesTime, BitCloud, chipKIT, chipKIT logo, CryptoMemory, CryptoRF, dsPIC, FlashFlex, flexPWR, HELDO, IGL00, JukeBlox, KeeLoq, Kleer, LANCheck, LinkMD, maXStylus, maXTouch, MediaLB, megaAVR, Microsemi, Microsemi logo, MOST, MOST logo, MPLAB, OptoLyzer, PackeTime, PIC, picoPower, PICSTART, PIC32 logo, PolarFire, Prochip Designer, QTouch, SAM-BA, SenGenuity, SpyNIC, SST, SST Logo, SuperFlash, Symmetricom, SyncServer, Tachyon, TimeSource, tinyAVR, UNI/O, Vectron, and XMEGA are registered trademarks of Microchip Technology Incorporated in the U.S.A. and other countries.

AgileSwitch, APT, ClockWorks, The Embedded Control Solutions Company, EtherSynch, FlashTec, Hyper Speed Control, HyperLight Load, IntelliMOS, Libero, motorBench, mTouch, Powermite 3, Precision Edge, ProASIC, ProASIC Plus, ProASIC Plus logo, Quiet-Wire, SmartFusion, SyncWorld, Temux, TimeCesium, TimeHub, TimePictra, TimeProvider, WinPath, and ZL are registered trademarks of Microchip Technology Incorporated in the U.S.A.

Adjacent Key Suppression, AKS, Analog-for-the-Digital Age, Any Capacitor, AnyIn, AnyOut, Augmented Switching, BlueSky, BodyCom, CodeGuard, CryptoAuthentication, CryptoAutomotive, CryptoCompanion, CryptoController, dsPICDEM, dsPICDEM.net, Dynamic Average Matching, DAM, ECAN, Espresso T1S, EtherGREEN, IdealBridge, In-Circuit Serial Programming, ICSP, INICnet, Intelligent Paralleling, Inter-Chip Connectivity, JitterBlocker, maxCrypto, maxView, memBrain, Mindi, MiWi, MPASM, MPF, MPLAB Certified logo, MPLIB, MPLINK, MultiTRAK, NetDetach, Omniscient Code Generation, PICDEM, PICDEM.net, PICkit, PICtail, PowerSmart, PureSilicon, QMatrix, REAL ICE, Ripple Blocker, RTAX, RTG4, SAM-ICE, Serial Quad I/O, simpleMAP, SimpliPHY, SmartBuffer, SMART-I.S., storClad, SQI, SuperSwitcher, SuperSwitcher II, Switchtec, SynchroPHY, Total Endurance, TSHARC, USBCheck, VariSense, VectorBlox, VeriPHY, ViewSpan, WiperLock, XpressConnect, and ZENA are trademarks of Microchip Technology Incorporated in the U.S.A. and other countries.

SQTP is a service mark of Microchip Technology Incorporated in the U.S.A.

The Adaptec logo, Frequency on Demand, Silicon Storage Technology, and Symmcom are registered trademarks of Microchip Technology Inc. in other countries.

GestIC is a registered trademark of Microchip Technology Germany II GmbH & Co. KG, a subsidiary of Microchip Technology Inc., in other countries.

All other trademarks mentioned herein are property of their respective companies.

© 2020-2021, Microchip Technology Incorporated, All Rights Reserved.

ISBN: 978-1-5224-7949-9

For information regarding Microchip's Quality Management Systems, please visit www.microchip.com/quality.



MICROCHIP

Worldwide Sales and Service

AMERICAS

Corporate Office
2355 West Chandler Blvd.
Chandler, AZ 85224-6199
Tel: 480-792-7200
Fax: 480-792-7277
Technical Support:
<http://www.microchip.com/support>
Web Address:
www.microchip.com

Atlanta

Duluth, GA
Tel: 678-957-9614
Fax: 678-957-1455

Austin, TX

Tel: 512-257-3370

Boston

Westborough, MA
Tel: 774-760-0087
Fax: 774-760-0088

Chicago

Itasca, IL
Tel: 630-285-0071
Fax: 630-285-0075

Dallas

Addison, TX
Tel: 972-818-7423
Fax: 972-818-2924

Detroit

Novi, MI
Tel: 248-848-4000

Houston, TX

Tel: 281-894-5983

Indianapolis

Noblesville, IN
Tel: 317-773-8323
Fax: 317-773-5453
Tel: 317-536-2380

Los Angeles

Mission Viejo, CA
Tel: 949-462-9523
Fax: 949-462-9608
Tel: 951-273-7800

Raleigh, NC

Tel: 919-844-7510

New York, NY

Tel: 631-435-6000

San Jose, CA

Tel: 408-735-9110
Tel: 408-436-4270

Canada - Toronto

Tel: 905-695-1980
Fax: 905-695-2078

ASIA/PACIFIC

Australia - Sydney
Tel: 61-2-9868-6733

China - Beijing
Tel: 86-10-8569-7000

China - Chengdu
Tel: 86-28-8665-5511

China - Chongqing
Tel: 86-23-8980-9588

China - Dongguan
Tel: 86-769-8702-9880

China - Guangzhou
Tel: 86-20-8755-8029

China - Hangzhou
Tel: 86-571-8792-8115

China - Hong Kong SAR
Tel: 852-2943-5100

China - Nanjing
Tel: 86-25-8473-2460

China - Qingdao
Tel: 86-532-8502-7355

China - Shanghai
Tel: 86-21-3326-8000

China - Shenyang
Tel: 86-24-2334-2829

China - Shenzhen
Tel: 86-755-8864-2200

China - Suzhou
Tel: 86-186-6233-1526

China - Wuhan
Tel: 86-27-5980-5300

China - Xian
Tel: 86-29-8833-7252

China - Xiamen
Tel: 86-592-2388138

China - Zhuhai
Tel: 86-756-3210040

ASIA/PACIFIC

India - Bangalore
Tel: 91-80-3090-4444

India - New Delhi
Tel: 91-11-4160-8631

India - Pune
Tel: 91-20-4121-0141

Japan - Osaka
Tel: 81-6-6152-7160

Japan - Tokyo
Tel: 81-3-6880-3770

Korea - Daegu
Tel: 82-53-744-4301

Korea - Seoul
Tel: 82-2-554-7200

Malaysia - Kuala Lumpur
Tel: 60-3-7651-7906

Malaysia - Penang
Tel: 60-4-227-8870

Philippines - Manila
Tel: 63-2-634-9065

Singapore
Tel: 65-6334-8870

Taiwan - Hsin Chu
Tel: 886-3-577-8366

Taiwan - Kaohsiung
Tel: 886-7-213-7830

Taiwan - Taipei
Tel: 886-2-2508-8600

Thailand - Bangkok
Tel: 66-2-694-1351

Vietnam - Ho Chi Minh
Tel: 84-28-5448-2100

EUROPE

Austria - Wels
Tel: 43-7242-2244-39
Fax: 43-7242-2244-393

Denmark - Copenhagen
Tel: 45-4485-5910
Fax: 45-4485-2829

Finland - Espoo
Tel: 358-9-4520-820

France - Paris
Tel: 33-1-69-53-63-20
Fax: 33-1-69-30-90-79

Germany - Garching
Tel: 49-8931-9700

Germany - Haan
Tel: 49-2129-3766400

Germany - Heilbronn
Tel: 49-7131-72400

Germany - Karlsruhe
Tel: 49-721-625370

Germany - Munich
Tel: 49-89-627-144-0
Fax: 49-89-627-144-44

Germany - Rosenheim
Tel: 49-8031-354-560

Israel - Ra'anana
Tel: 972-9-744-7705

Italy - Milan
Tel: 39-0331-742611
Fax: 39-0331-466781

Italy - Padova
Tel: 39-049-7625286

Netherlands - Drunen
Tel: 31-416-690399
Fax: 31-416-690340

Norway - Trondheim
Tel: 47-7288-4388

Poland - Warsaw
Tel: 48-22-3325737

Romania - Bucharest
Tel: 40-21-407-87-50

Spain - Madrid
Tel: 34-91-708-08-90
Fax: 34-91-708-08-91

Sweden - Gothenberg
Tel: 46-31-704-60-40

Sweden - Stockholm
Tel: 46-8-5090-4654

UK - Wokingham
Tel: 44-118-921-5800
Fax: 44-118-921-5820