

REVISIONS			
REV	DESCRIPTION, ECN, EAR NO.	DATE	APP'D
A	PROPOSAL DRAWING	NOV.9,2021	A.G
B	UPDATE RECOMMENDED PCB LAYOUT	JUN.13,2022	K.T

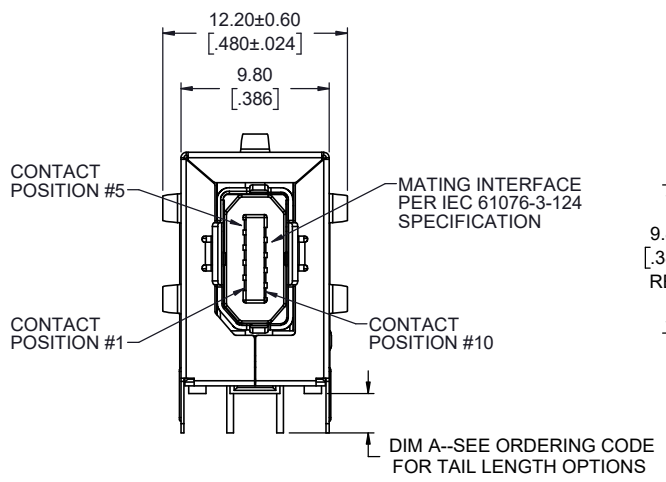

**FRONT VIEW
(TYPE A SHOWN)**

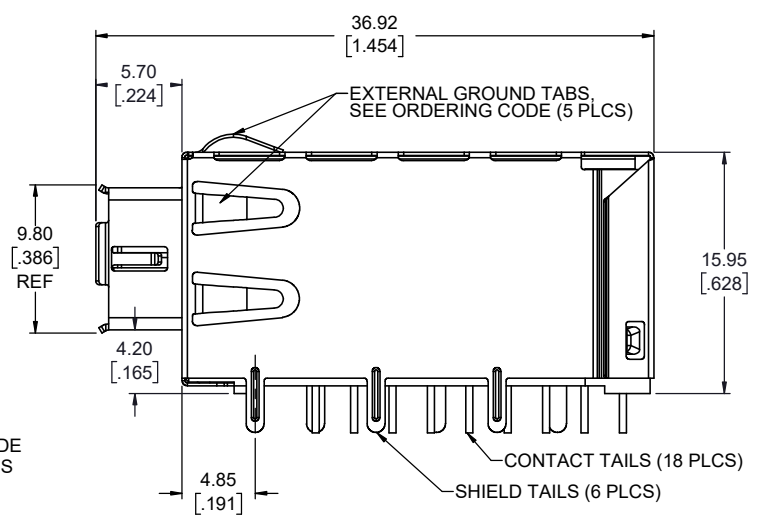

SIDE VIEW

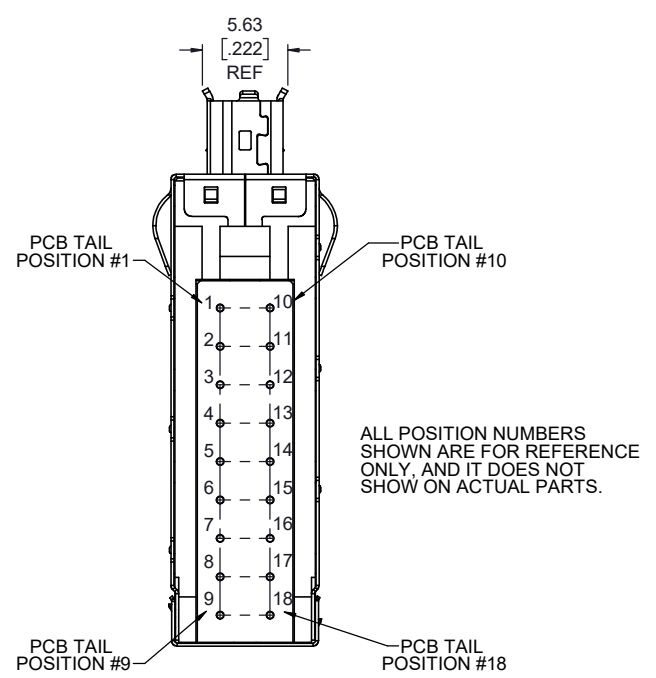

BOTTOM VIEW

ALL POSITION NUMBERS SHOWN ARE FOR REFERENCE ONLY, AND IT DOES NOT SHOW ON ACTUAL PARTS.

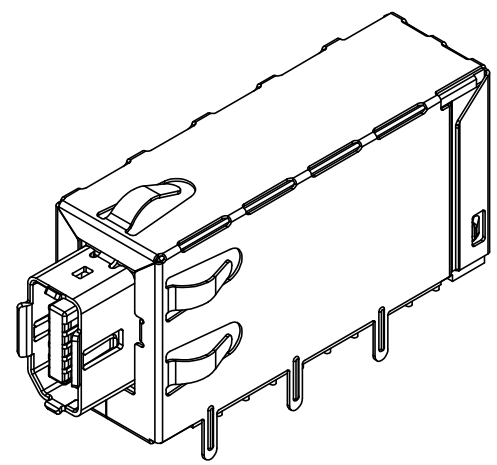

NOTES:

- MATERIALS:**
 - OUTER MAIN SHIELD: STAINLESS STEEL, TIN FINISHED TAILS. FRONT SHIELD: STAINLESS STEEL.
 - INSERTS: HIGH TEMPERATURE RESISTANT ENGINEERING THERMOPLASTIC, GLASS REINFORCED, UL94V-0, BLACK.
 - CONTACTS: COPPER ALLOY PLATED WITH GOLD OVER 1.27µm (50µ") MINIMUM NICKEL ON THE MATING AREA, AND MATTE TIN ON THE TERMINAL TAILS.
- MECHANICAL:**
 - MATING & UNMATING FORCE: 25N (5.6 lbf) MAXIMUM
- ELECTRICAL:**
 - VOLTAGE RATING: 60VDC.
 - CONTACT RESISTANCE: 30 MILLIOHMS MAXIMUM.
 - SEE SHEET 2 FOR MAGNETICS DETAILS.
- ENVIRONMENTAL:**
 - STORAGE TEMPERATURE: -40° TO +85°.
 - OPERATING TEMPERATURE: -40° TO +85°.
 - RECOMMENDED SOLDER PROCESS: WAVE OR IR REFLOW, PEAK SOLDERING TEMPERATURE 260°C FOR 5-8 SECONDS.
- DESIGNED TO CONFORM TO REQUIREMENTS OF IEC 61076 PART 3-124 SPECIFICATION. THE TYPE A KEY FEATURE SHOWN IS INTENDED FOR USE WITH ETHERNET APPLICATIONS, EITHER 10/100 MBIT/S OR 1 TO 10 GBIT/S (CAT 5e, 6 & 6A). THE TYPE B KEY, WHILE NOT INTENDED FOR ETHERNET, MAY BE USED IN A COMPLEX ETHERNET APPLICATION TO HELP CONTROL MATING PLUG INSTALLATIONS.

ORDERING CODE: NDM - XXXX1 - 00

SERIES, IX INDUSTRIAL WITH MAGNETICS

A: TYPE A KEY FOR ETHERNET.
B: TYPE B KEY.

EMI SHIELD TAB OPTION:
1: WITH EXTERNAL TABS.
2: WITHOUT EXTERNAL TABS.

DIM A - TAIL LENGTH OPTIONS:
3 = 2.40mm (.094")
4 = 3.20mm (.126")
5 = 4.00mm (.157")

RIGHT ANGLE STANDARD

WITH PoE FUNCTION.

GOLD PLATING THICKNESS OPTIONS FOR MATING AREA:
2 = 0.20µm (8µ") GOLD
4 = 1.27µm (50µ") GOLD



UNLESS SPECIFIED OTHERWISE	DRAWN	KELVIN T	OCT.3,21
PRIMARY UNITS MILLIMETERS	CHECKED	KENT LAMBIE	OCT.6,21
SECONDARY INCHES	M.E. APP'D		
REFERENCE IN PARENTHESES	Q.A. APP'D		
GENERAL TOLERANCES	DWG APPR.	ADRIAN	NOV.9,21
1 DECIMAL PLACE ±0.38	ENG. REL. NO.	EAR RJ21018	
2 DECIMAL PLACES ±0.25	REF.		
3 DECIMAL PLACES	THIRD ANGLE PROJECTION		
ANGULAR DEGREES	DO NOT SCALE DRAWING		

Amphenol Canada Corp.
Commercial Products

IX INDUSTRIAL CONNECTOR WITH MAGNETICS, PoE & CAT6A HIGH SPEED PERFORMANCE, RoHS COMPLIANT

P-NDM-XXXX1-00

CODE ID NO. 03554 DWG SIZE: X SCALE: 4:1 SHEET 1 OF 3

SCHEMATIC DRAWING

MATING POSITION NUMBER

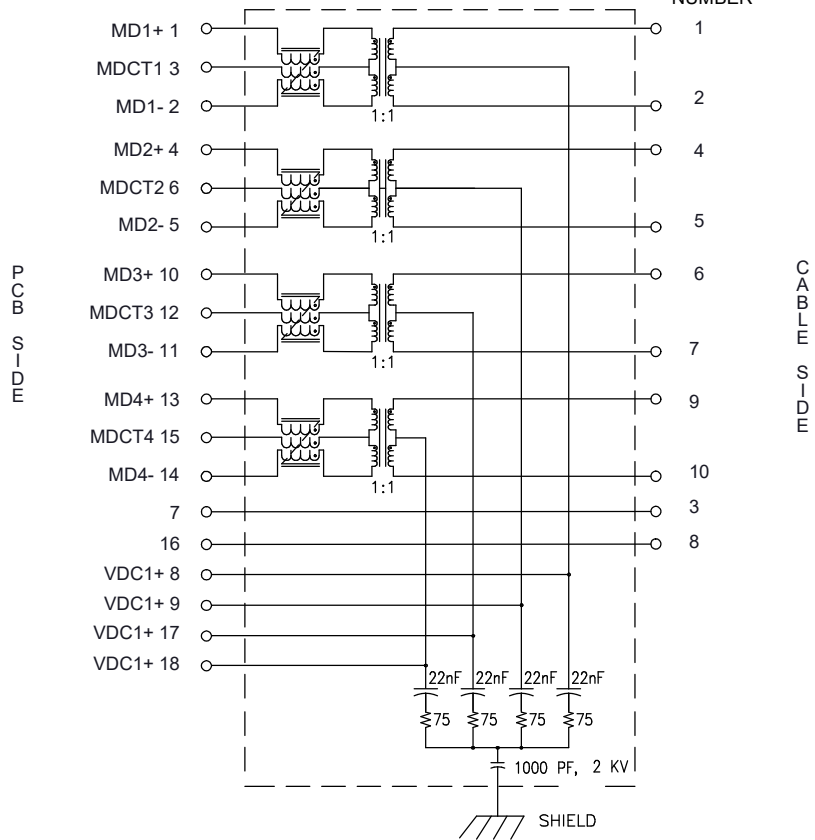

CONNECTOR PIN ASSIGNMENT	
MATING POSITION NUMBER	PIN ASSIGNMENT 1, 2, 5, 5 OR 10 Gb/s ETHERNET
1	BI_DA +
2	BI_DA -
3	GND
4	BI_DC +
5	BI_DC -
6	BI_DB +
7	BI_DB -
8	GND
9	BI_DD +
10	BI_DD -

REVISIONS			
REV	DESCRIPTION, ECN, EAR NO.	DATE	APP'D
A	PROPOSAL DRAWING	NOV.9.2021	A.G
B	UPDATE RECOMMENDED PCB LAYOUT	JUN.13.2022	K.T



ELECTRICAL SPECIFICATION (@ 25 °C)

PARAMETER	LIMITS	TEST CONDITIONS
TURN RATIO	1:1 ±3%	
POLARITY	PER SCHEMATIC	
INSERTION LOSS	-2.0dB MAX.	1~400 MHz
	-3.0dB MAX.	400~500 MHz
RETURN LOSS	-22dB MIN.	1~100 MHz
	-22 + 20.75 log(F/100) dB MIN.	100~500 MHz
INDUCTANCE (OCL)	160 µH MIN. @100KHz 100mV	
CROSSTALK ISOLATION	-28dB MIN.	1~100 MHz
	-19dB MIN.	100~500 MHz
COMMON MODE REJECTION RATIO	-30dB MIN.	1~40 MHz
	-20dB MIN.	40~500 MHz
COMMON TO DIFFERENTIAL MODE REJECTION (CDMR)	-30dB MIN.	1~250 MHz
	-20dB MIN.	250~500 MHz
HIPOT (ISOLATION)	1,500VAC MIN. 1mA	60 SECONDS
CURRENT RATING	960 mA FOR EACH OF FOUR DIFFERENTIAL PAIRS	

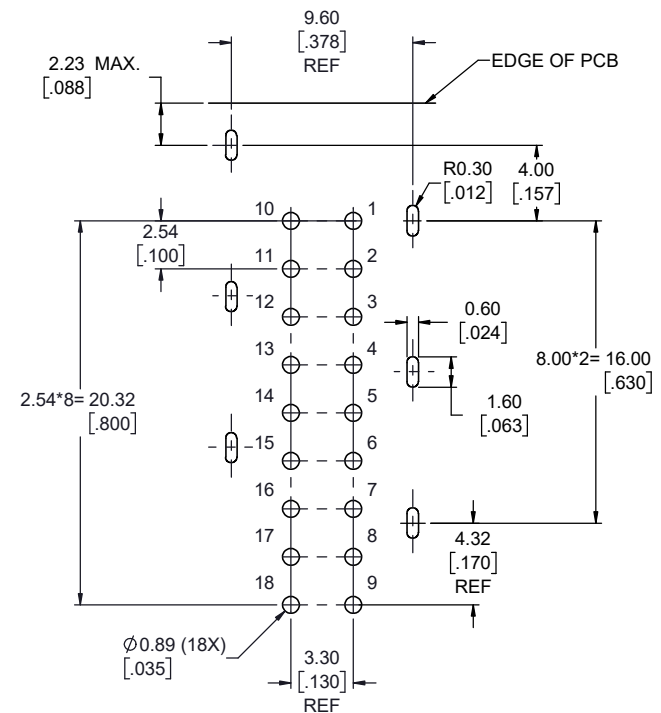

RECOMMENDED PCB LAYOUT
COMPONENT SIDE OF PCB
(+/-0.05mm)

UNLESS SPECIFIED OTHERWISE	DRAWN	KELVIN T	OCT.3.21
PRIMARY UNITS MILLIMETERS	CHECKED	KENT LAMBIE	OCT.6.21
SECONDARY UNITS INCHES	M.E. APP'D		
REFERENCE IN PARENTHESES	Q.A. APP'D		
GENERAL TOLERANCES	DWG APPR.	ADRIAN	NOV.9.21
1 DECIMAL PLACE ±0.38	ENG. REL. NO.	EAR RJ21018	
2 DECIMAL PLACES ±0.25	REF.		
3 DECIMAL PLACES	THIRD ANGLE PROJECTION		
ANGULAR DEGREES	DO NOT SCALE DRAWING		

Amphenol Canada Corp.
Commercial Products

IX INDUSTRIAL CONNECTOR WITH MAGNETICS, PoE & CAT6A HIGH SPEED PERFORMANCE, RoHS COMPLIANT

DWG. NO. **P-NDM-XXXX1-00** REV **B**

CODE ID NO. 03554 | DWG SIZE: X | SCALE: 4:1 | SHEET 2 OF 3

REVISIONS			
REV	DESCRIPTION, ECN, EAR NO.	DATE	APP'D
A	PROPOSAL DRAWING	NOV.9.2021	A.G
B	UPDATE RECOMMENDED PCB LAYOUT	JUN.13.2022	K.T

TYPE A KEY WITH EXTERNAL TABS
PART NUMBER: NDM-A1XX1-00

TYPE A KEY WITHOUT EXTERNAL TABS
PART NUMBER: NDM-A2XX1-00

TYPE B KEY WITH EXTERNAL TABS
PART NUMBER: NDM-B1XX1-00

TYPE B KEY WITHOUT EXTERNAL TABS
PART NUMBER: NDM-B2XX1-00

ALL POSITION NUMBERS SHOWN ARE FOR REFERENCE ONLY, AND IT DOES NOT SHOW ON ACTUAL PARTS.

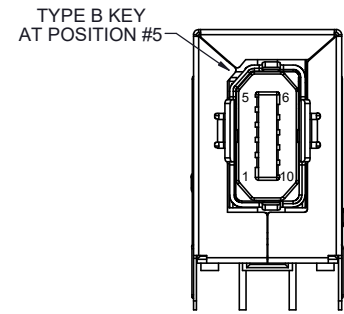
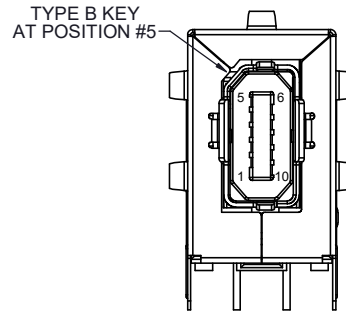
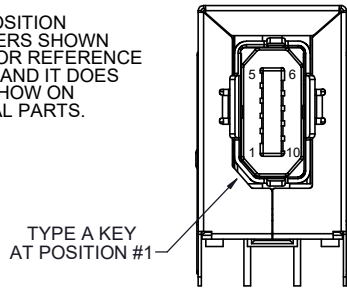
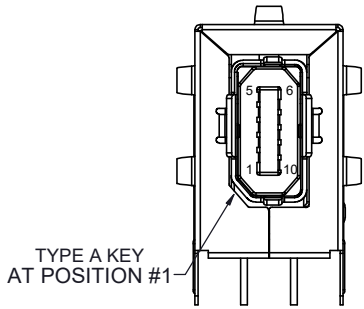

RECOMMENDED PANEL CUTOUT FOR EXTERNAL TABS
PART NUMBER: NDM-X1XX1-00

RECOMMENDED PANEL CUTOUT WITHOUT EXTERNAL TABS
PART NUMBER: NDM-X2XX1-00

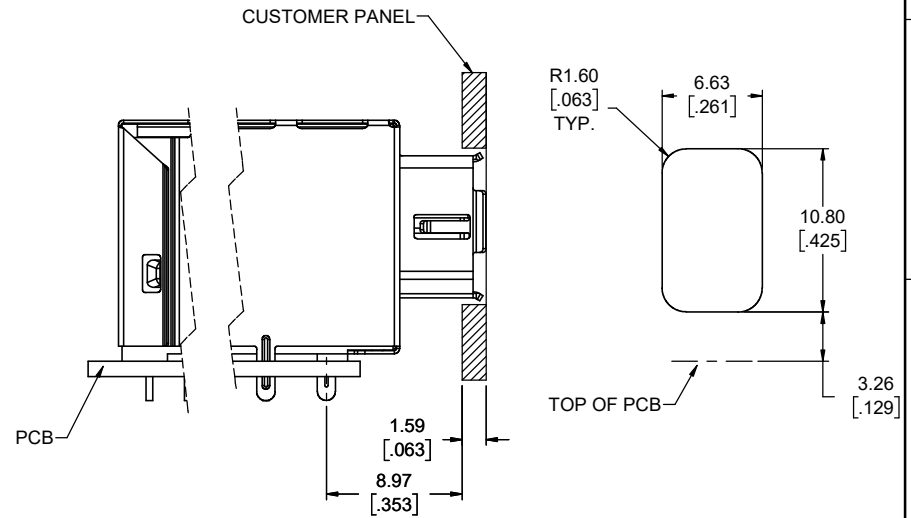
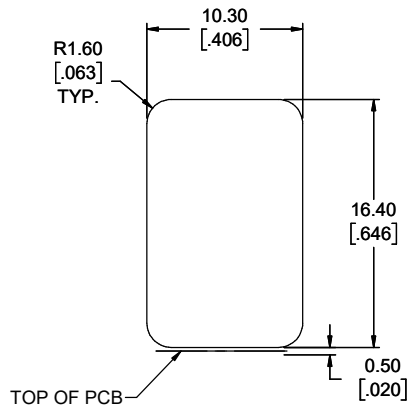
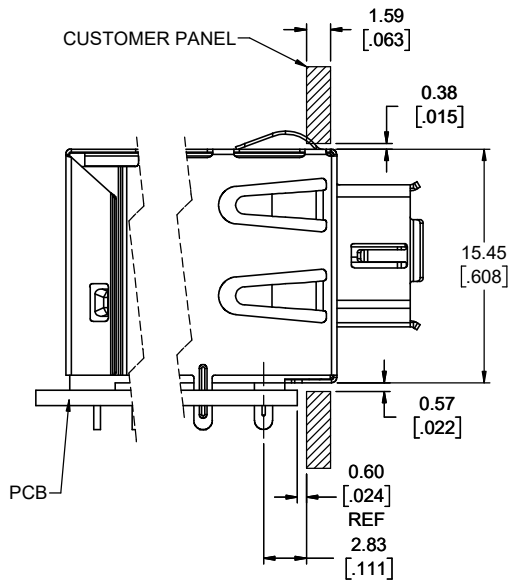

UNLESS SPECIFIED OTHERWISE	DRAWN	KELVIN T	OCT.3.21
PRIMARY UNITS MILLIMETERS	CHECKED	KENT LAMBIE	OCT.6.21
SECONDARY INCHES	M.E. APP'D		
REFERENCE IN PARENTHESES	Q.A. APP'D		
GENERAL TOLERANCES	DWG APPR.	ADRIAN	NOV.9.21
1 DECIMAL PLACE ±0.38	ENG. REL. NO.	EAR RJ21018	
2 DECIMAL PLACES ±0.25	REF.		
3 DECIMAL PLACES	THIRD ANGLE PROJECTION		
ANGULAR DEGREES	DO NOT SCALE DRAWING		

Amphenol Canada Corp.
Commercial Products
IX INDUSTRIAL CONNECTOR WITH MAGNETICS, PoE & CAT6A HIGH SPEED PERFORMANCE, RoHS COMPLIANT

DWG. NO. **P-NDM-XXXX1-00** REV **B**

CODE ID NO. 03554 DWG SIZE: X SCALE: 4:1 SHEET 3 OF 3