

© - TE Connectivity. All Rights Reserved.

REVISIONS

P	LTR	DESCRIPTION	DATE	DWN	APVD
C		ADD RIBS	ECO-11-018616	05-JAN-21	XN.Z S.C

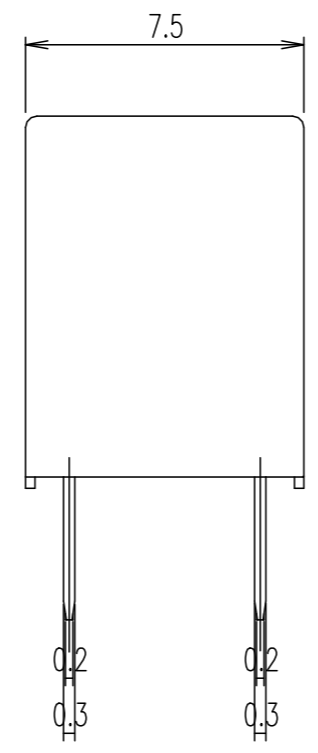
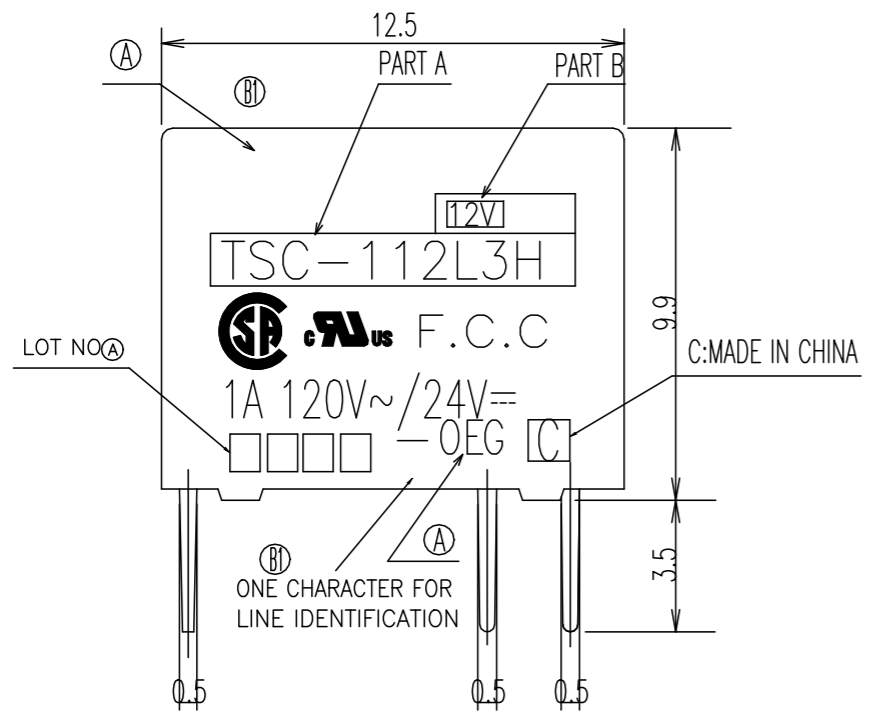
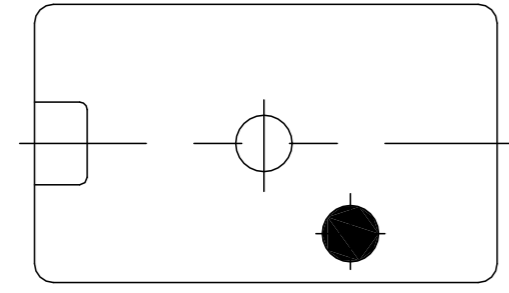

DRILLING DIAGRAM (BOTTOM VIEW)

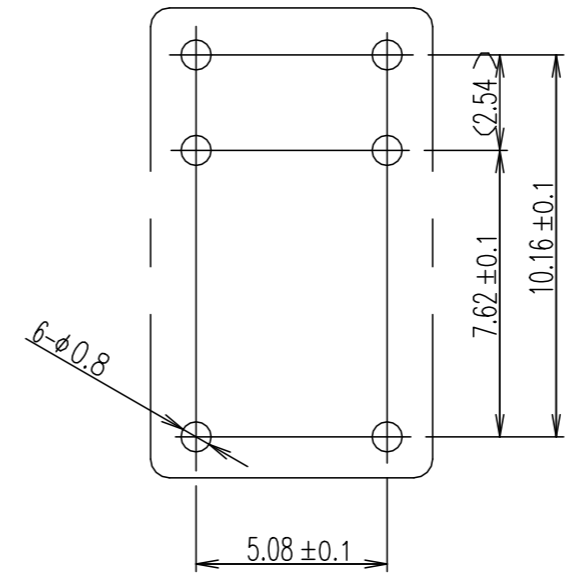

CONNECTION DIAGRAM (BOTTOM VIEW)

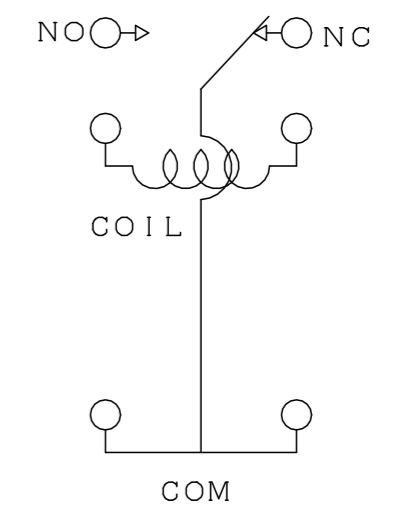

- B1** NOTES:
- LOT NO. SYSTEM AS FOLLOWING:
 - TERMINAL DIMENSIONS BEFORE SOLDER DIP
 - FOR THE TIN-PLATING OF THE PINS:
 +0.1mm FOR WIDTH, THICKNESS AND DIAMETER
 +0.5mm FOR LENGTH

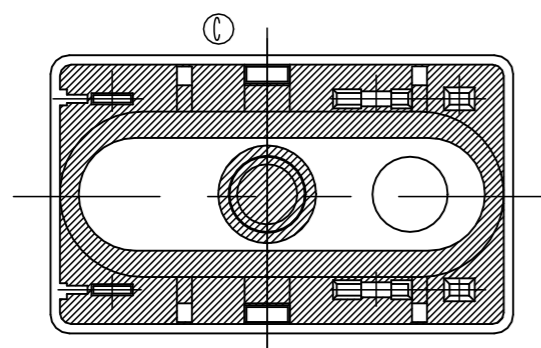

THIS DRAWING IS A CONTROLLED DOCUMENT.		DWN N.FUNAYAMA	STE TE Connectivity Ltd.		
DIMENSIONS: mm		CHK H.SASAKI			
TOLERANCES UNLESS OTHERWISE SPECIFIED:		APVD A.NAGAI	TSC SPECIA; L TYPE		
0 PLC ± -		PRODUCT SPEC	RESTRICTED TO		
1 PLC ± -		APPLICATION SPEC	SIZE	CAGE CODE	DRAWING NO
2 PLC ± -		WEIGHT	A3	00779	C-1461185
3 PLC ± -		CUSTOMER DRAWING	SCALE	SHEET	REV
4 PLC ± -			5:1	1 OF 2	C
ANGLES ± -					
FINISH					

© - TE Connectivity. All Rights Reserved.

REVISIONS

P	LTR	DESCRIPTION	DATE	DWN	APVD
-	-	SEE SHEET 1	-	-	-

GENERAL TOLERANCE

DIAGRAM DIMENSION	TOLERANCE
0.99mm max.	±0.1mm
1 - 2.99mm	±0.2mm
3mm min.	±0.3mm



n	5-1440007-3	TSC-124D3H	24V	108-79510	ACTIVE
m	1461185-4	TSC-118D3H	18V	108-79509	OBSOLETE
l	2-1419130-1	TSC-112D3H	12V	108-79508	ACTIVE
k	1461185-3	TSC-109D3H	9V	108-79507	OBSOLETE
j	1-1419130-4	TSC-106D3H	6V	108-79506	OBSOLETE
i	1-1419130-0	TSC-105D3H	5V	108-79505	ACTIVE
h	1461185-2	TSC-103D3H	3V	108-79504	OBSOLETE
g	2-1419130-8	TSC-124L3H	24V	108-79503	ACTIVE
f	1461185-1	TSC-118L3H	18V	108-79502	OBSOLETE
e	2-1419130-4	TSC-112L3H	12V	108-79501	ACTIVE
d	1-1419130-8	TSC-109L3H	9V	108-79500	ACTIVE
c	1-1419130-5	TSC-106L3H	6V	108-79499	OBSOLETE
b	1-1419130-2	TSC-105L3H	5V	108-79498	ACTIVE
a	5-1440007-2	TSC-103L3H	3V	108-79497	ACTIVE
No.	TE PART NO.	PART A	PART B	PRODUCT SPEC NO	STATUS

RELAY TYPE

			UV SEAL (FOR SEALED TYPE)	15
		EPOXY RESIN	SEAL (CASE&BASE) MIX	14
	SOLDER DIP	Cu ALLOY	COIL TERMINAL	13
94V-0		PBT	BOBBIN	12
		UEW	MAGNETIC WIRE	11
94V-0		PBT	CASE	10
	Ni P	STEEL	YOKE	9
	Ni P	STEEL	ARMATURE	8
	Ni P	STEEL	CORE	7
	SOLDER DIP	Cu ALLOY	MOVABLE SPRING	6
	SOLDER DIP	Cu ALLOY	B TERMINAL	5
	SOLDER DIP	Cu ALLOY	M TERMINAL	4
	GS CLAD	Ag ALLOY	MOVABLE CONTACT	3
	GS CLAD	Ag ALLOY	B CONTACT	2
	GS CLAD	Ag ALLOY	M CONTACT	1
UL-94	FINISH	MATERIAL	DESCRIPTION	ITEM

THIS DRAWING IS A CONTROLLED DOCUMENT.		DWN N.FUNAYAMA		TE Connectivity Ltd.	
DIMENSIONS: mm		CHK H.SASAKI			
TOLERANCES UNLESS OTHERWISE SPECIFIED:		APVD A.NAGAI		NAME	
0 PLC ± -		PRODUCT SPEC		TSC SPECIA;L TYPE	
1 PLC ± -		APPLICATION SPEC		SIZE	
2 PLC ± -		WEIGHT		CAGE CODE	
3 PLC ± -		CUSTOMER DRAWING		DRAWING NO	
4 PLC ± -		SCALE 5:1		SHEET 2 OF 2	
ANGLES ± -		RESTRICTED TO		REV C	
FINISH		A300779		1461185	