

THIS DRAWING IS UNPUBLISHED. RELEASED FOR PUBLICATION
 © COPYRIGHT - By - ALL RIGHTS RESERVED.

LOC		DIST		REVISIONS			DATE	OWN	APVD
P	LTR	DESCRIPTION							
	T	REV PER ECO 15-001152			1-23-15	CT	CD		

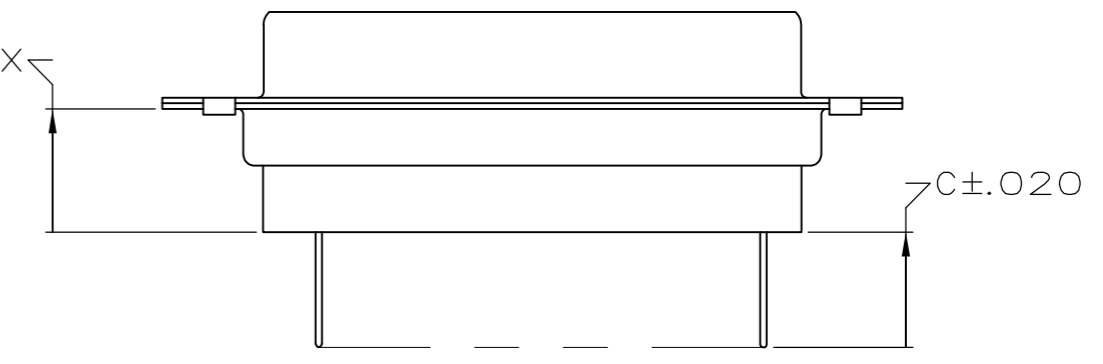
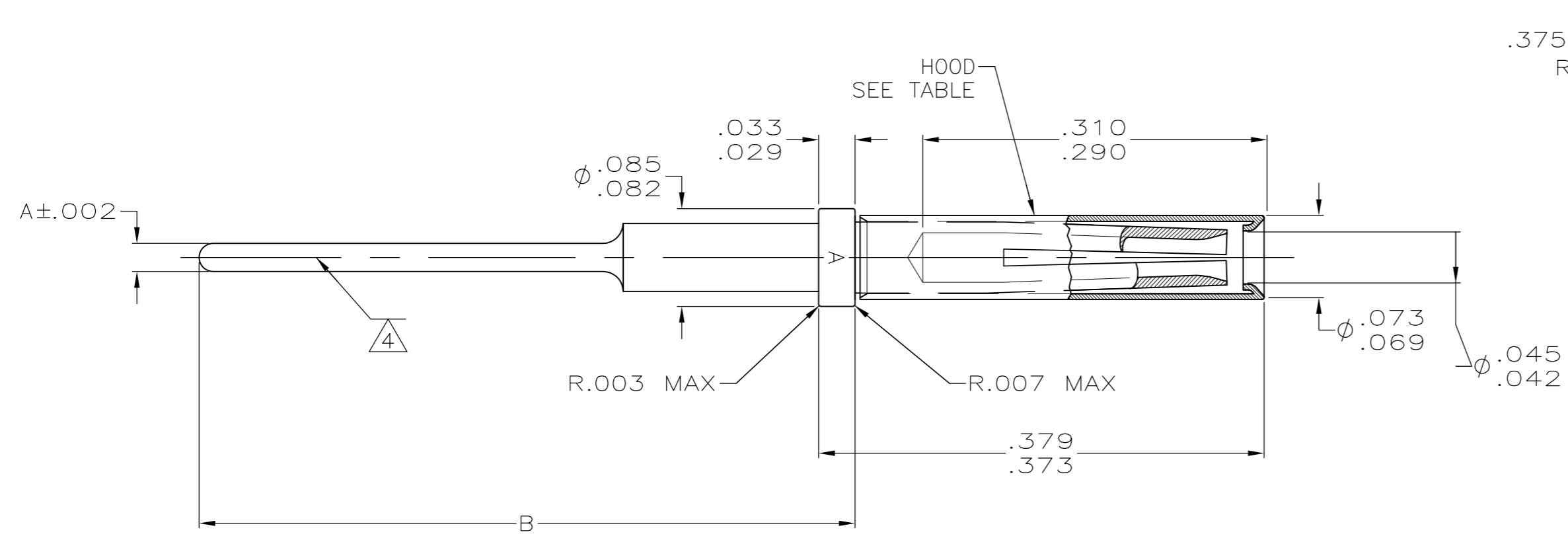

POST EXTENTION WHEN USED
 IN A STANDARD CONNECTOR

- 1. PLATED GOLD .000050 MIN THK, OVER COPPER .000150 MIN THK
- 2. FOR USE IN P.C. BOARD.
- 3. CONTACT CAN BE USED IN ANY STANDARD HD-20 RECEPTACLE CONNECTOR.
- 4. POINT OF PLATING MEASUREMENT .100 FROM TIP OF SOLDER TAIL.
- 5. PLATED GOLD .000050-.000100 THK PER ASTM-B488, TYPE I, CODE C OVER NICKEL PER QQ-N-290, .000050 TO .000150 INCH THK.
- 6. CONTACT BODY MAT'L: COPPER ALLOY PER ASTM-B196 OR ASTM-B197
- 7. CONTACTS MEET ALL APPLICABLE PERFORMANCE REQUIREMENTS OF SAE-AS39029.
- 8. HOOD: STAINLESS STEEL, UNS S30500 IAW ASTM A240/A240M FINISH: PASSIVATED PER AMS 2700 METHOD 1, TYPE OPTIONAL, CLASS 4.
- 9. HOOD: BRASS PER QQ-B-613 OR BERYLLIUM COPPER PER ASTM-B-196. PLATED GOLD PER MIL-B488 OVER COPPER PER AMS 2418.

	1	9	C	B	A	PART NO.
PRELIMINARY NOT RELEASED FOR PRODUCTION	-	-	.320	.560	.018	1-208778-5
PRELIMINARY NOT RELEASED FOR PRODUCTION	-	-	-	-	-	1-208778-4
PRELIMINARY NOT RELEASED FOR PRODUCTION	-	-	-	-	-	1-208778-3
	1	8	.240	.480	.018	1-208778-2
	5	8	.320	.560	.018	1-208778-1
	1	8	.320	.560	.018	1-208778-0
OBSOLETE	1	8	.190	.446	.040	208778-9
OBSOLETE	1	8	.190	.446	.030	208778-8
OBSOLETE	1	8	.190	.446	.024	208778-7
OBSOLETE	1	8	.155	.415	.040	208778-6
OBSOLETE	1	8	.155	.415	.030	208778-5
OBSOLETE	1	8	.155	.415	.024	208778-4
OBSOLETE	1	8	.125	.383	.040	208778-3
OBSOLETE	1	8	.125	.383	.030	208778-2
OBSOLETE	1	8	.125	.383	.024	208778-1

THIS DRAWING IS A CONTROLLED DOCUMENT.		DWN T. THOMPSON 08-18-93	TE Connectivity	
DIMENSIONS: mm [INCHES]		CHK D. MANTIONE 08-23-93		
TOLERANCES UNLESS OTHERWISE SPECIFIED:		APVD D. MANTIONE 08-23-93	NAME SOCKET CONTACT POSTED, SIZE 20 ASSEMBLY	
0 PLC ± - 1 PLC ± - 2 PLC ± - 3 PLC ± .005 4 PLC ± - ANGLES ± -		PRODUCT SPEC -	SIZE A2	
MATERIAL SEE CALLOUT		APPLICATION SPEC -	CAGE CODE 00779	DRAWING NO G-208778
FINISH SEE CALLOUT		WEIGHT -	RESTRICTED TO -	
CUSTOMER DRAWING			SCALE 10:1	SHEET 1 OF 1