



soberton inc.

GT MAGNETIC BUZZER

Acoustic Product Specification

Product Number: GT-111PS-1



Release | Revision: C/2018

CONTENTS

This document contains the technical specifications for the electromagnetic buzzer.

Page 1

Specifications

Mechanical Characteristics

Page 2

Environment Test

Reliability Test

Page 3

Recommended Temperature Profile

Measurement Test Circuit

Inspection Fixture

Page 4

Frequency Response Curve

Page 5

Dimensions

Page 6

Packing

Specifications

Item	Unit	Specification	Condition
Rated Frequency	Hz	2048	Vo-p= 1/2 duty, square wave
Rated Voltage	Vo-p	1.5	Vo-p 
Operating Voltage	Vo-p	1.0 ~ 3.0	
Mean Current	mA	15 Max.	At rated voltage
Sound Pressure Level	dB	70	At 10cm at rated voltage
Coil Resistance	Ω	50±7	
Operating Temp	°C	-20 ~ +60	
Storage Temp	°C	-20 ~ +70	
Dimension	mm	φ 12.0×H5.4	See attached drawing
Weight	gram	2.0	
Housing Material		PPO	
Terminal		PIN Type (Plating Sn)	See attached drawing
Environmental Protection Regulation		RoHS	

Test condition

Temperature: 25±2 °C Related humidity: 65±5% Air pressure: 86-106KPa

Mechanical Characteristics

Item	Test condition	Evaluation standard
Solderability	Lead terminals are immersed in the solder bath at +250±5°C for 3±1 seconds.	90% min. lead terminals shall be wet with solder. No interference in operation.
Soldering Heat Resistance	Lead terminals are immersed in the soldering bath at +250±5°C for ±2 seconds.	
Terminal Mechanical Strength	The force of 9.8N is applied to each terminal in axial direction for 10 seconds.	No damage and cutting off.
Vibration	The part shall be subjected to a vibration cycle of 10Hz to 55Hz to 10Hz in a period of 1 minute. Total peak amplitude shall be 1.52mm(9.3G). The vibration test shall consist of 2 hours per axis in each three axes(X,Y,Z). Total 6 hours.	After the test, the part shall meet specifications without any damage in appearance and performance except SPL. The SPL should be in ±10dBA compared with initial one.
Drop Test	The part is dropped from a height of 75cm onto a 40mm thick wooden board 3 times in 3 axes (X,Y,Z). A total of 9 times.	



soberton inc.

GT MAGNETIC BUZZER

Acoustic Product Specification

Product Number: GT-111PS-1



Release | Revision: C/2018

CONTENTS

This document contains the technical specifications for the electromagnetic buzzer.

Page 1

Specifications

Mechanical Characteristics

Page 2

Environment Test

Reliability Test

Page 3

Recommended Temperature Profile

Measurement Test Circuit

Inspection Fixture

Page 4

Frequency Response Curve

Page 5

Dimensions

Page 6

Packing

Environment Test

Item	Test condition	Evaluation standard
High Temp. Test	The part is placed in a chamber at +70°C for 96 hours.	After the test, the part shall meet specifications without any degradation in appearance and performance except SPL. After 4 hours at +25°C, the SPL should be in ±10dBA compared with initial one.
Low Temp. Test	The part is placed in a chamber at -30°C for 96 hours.	
Thermal Shock	The part shall be subjected to 5 cycles. Each cycle shall consist of:	

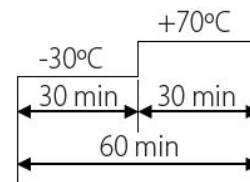

Temp./Humidity Cycle
The part will be subjected to 5 cycles. One cycle shall be 24 hours and consist of:

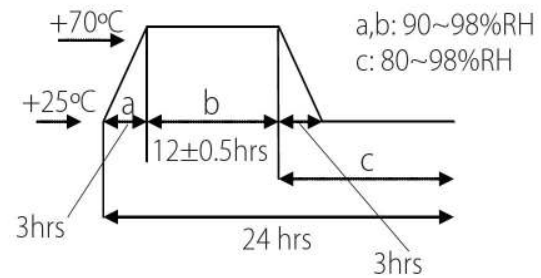

Reliability Test

Item	Test condition	Evaluation standard
Operating Life Test	Ordinary Temperature The part shall be subjected to 96 hours of continuous operation at +25±10°C.	After the test, the part shall meet specifications without any degradation in appearance and performance except SPL. After 4 hours at +25°C, the SPL should be in ±10dBA compared with initial one.
	High Temperature The part shall be subjected to 72 hours of continuous operation at +70°C at 1.5 V, 2048 Hz applied.	
	Low Temperature The part shall be subjected to 72 hours of continuous operation at -30°C at 1.5 V, 2048 Hz applied.	

Standard test condition:

- a) Temperature: +5~+35°C
- b) Humidity: 45~85%
- c) Pressure: 86~106KPa



soberton inc.

GT MAGNETIC BUZZER

Acoustic Product Specification

Product Number: GT-111PS-1



Release | Revision: C/2018

CONTENTS

This document contains the technical specifications for the electromagnetic buzzer.

Page 1

Specifications

Mechanical Characteristics

Page 2

Environment Test

Reliability Test

Page 3

Recommended Temperature Profile

Measurement Test Circuit

Inspection Fixture

Page 4

Frequency Response Curve

Page 5

Dimensions

Page 6

Packing

Recommended Temperature Profile for Reflow Oven

Recommendable wave soldering condition is as follows:

Note 1: It is requested that reflow soldering should be executed after heat of product goes down to normal temperature.

Note 2: Peak reflow temperature of 250°C maximum of 10 seconds, with a maximum duration of 40-60 seconds between 220°C and 250°C

* Wave Soldering profile of lead-free

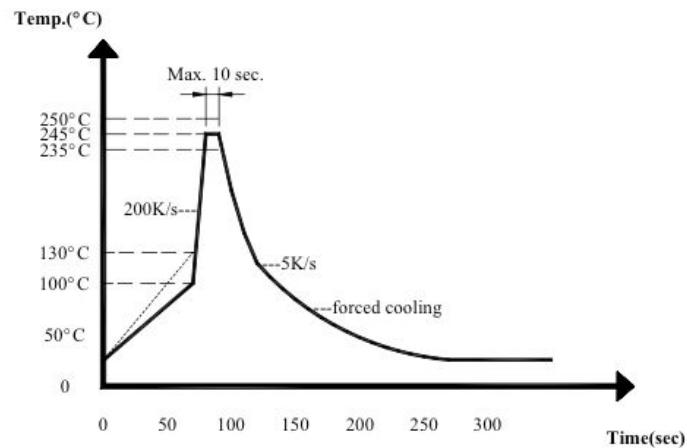

Measurement Test Circuit

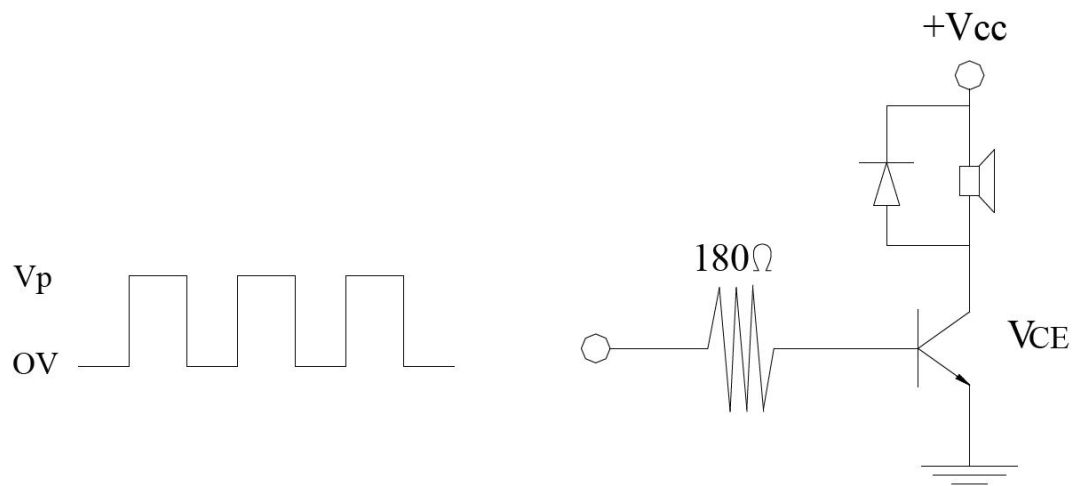

Inspection Fixture

S.P.L Measuring Circuit

Input Signal : 1.5 Vo-p, square wave, 1/2 duty, 2048Hz

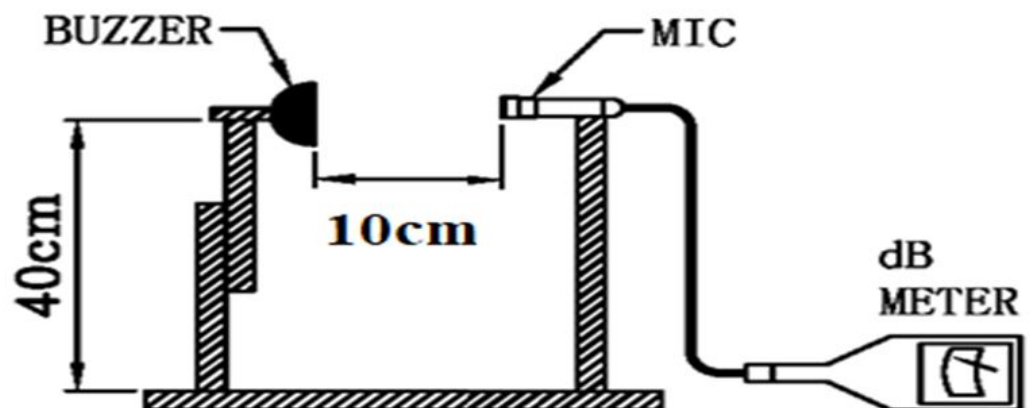

Mic: RION S.P.L meter UC30 or equivalent

S.G: Hewlett Packard 33120A Function Generator or equivalent



soberton inc.

GT MAGNETIC BUZZER

Acoustic Product Specification

Product Number: GT-111PS-1



Release | Revision: C/2018

CONTENTS

This document contains the technical specifications for the electromagnetic buzzer.

Page 1

Specifications

Mechanical Characteristics

Page 2

Environment Test

Reliability Test

Page 3

Recommended Temperature Profile

Measurement Test Circuit

Inspection Fixture

Page 4

Frequency Response Curve

Page 5

Dimensions

Page 6

Packing

Frequency Response Curve

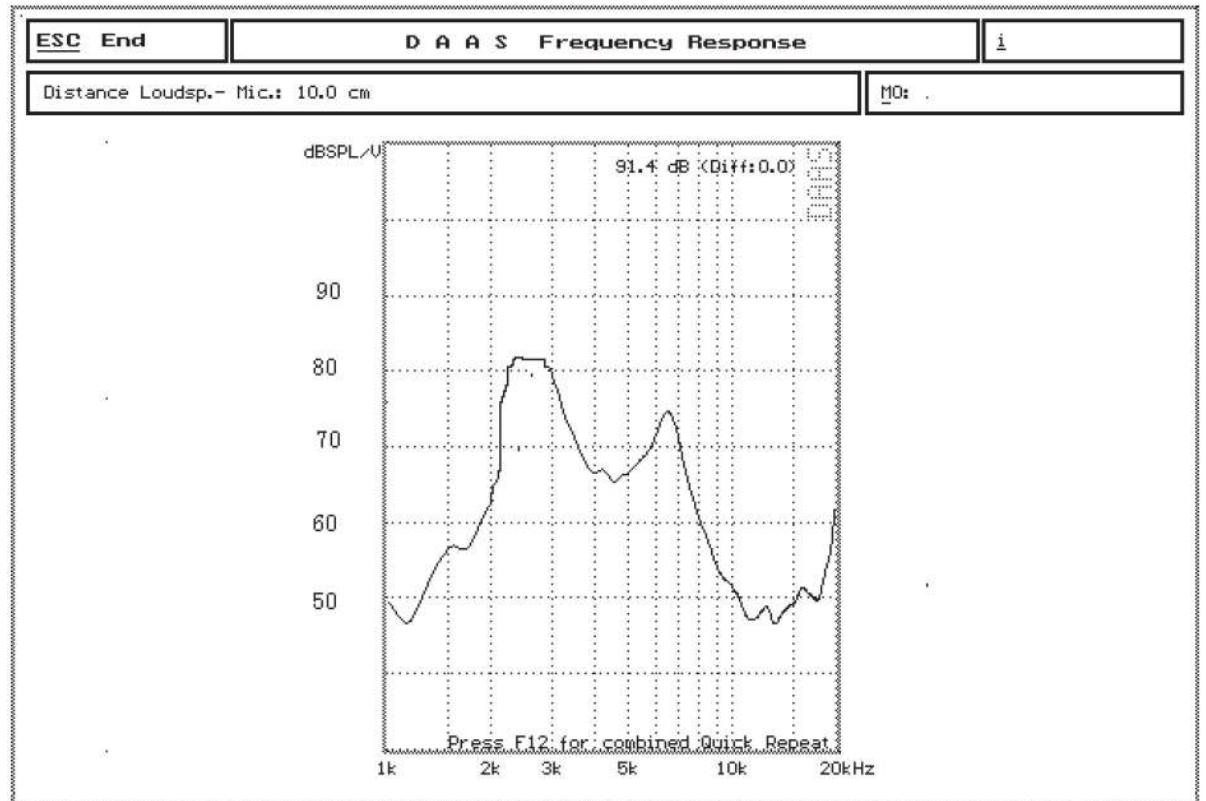



soberton inc.

GT MAGNETIC BUZZER

Acoustic Product Specification

Product Number: GT-111PS-1



Release | Revision: C/2018

CONTENTS

This document contains the technical specifications for the electromagnetic buzzer.

Page 1

Specifications

Mechanical Characteristics

Page 2

Environment Test

Reliability Test

Page 3

Recommended Temperature Profile

Measurement Test Circuit

Inspection Fixture

Page 4

Frequency Response Curve

Page 5

Dimensions

Page 6

Packing

Dimensions

Tolerance: ± 0.5 (unit: mm)

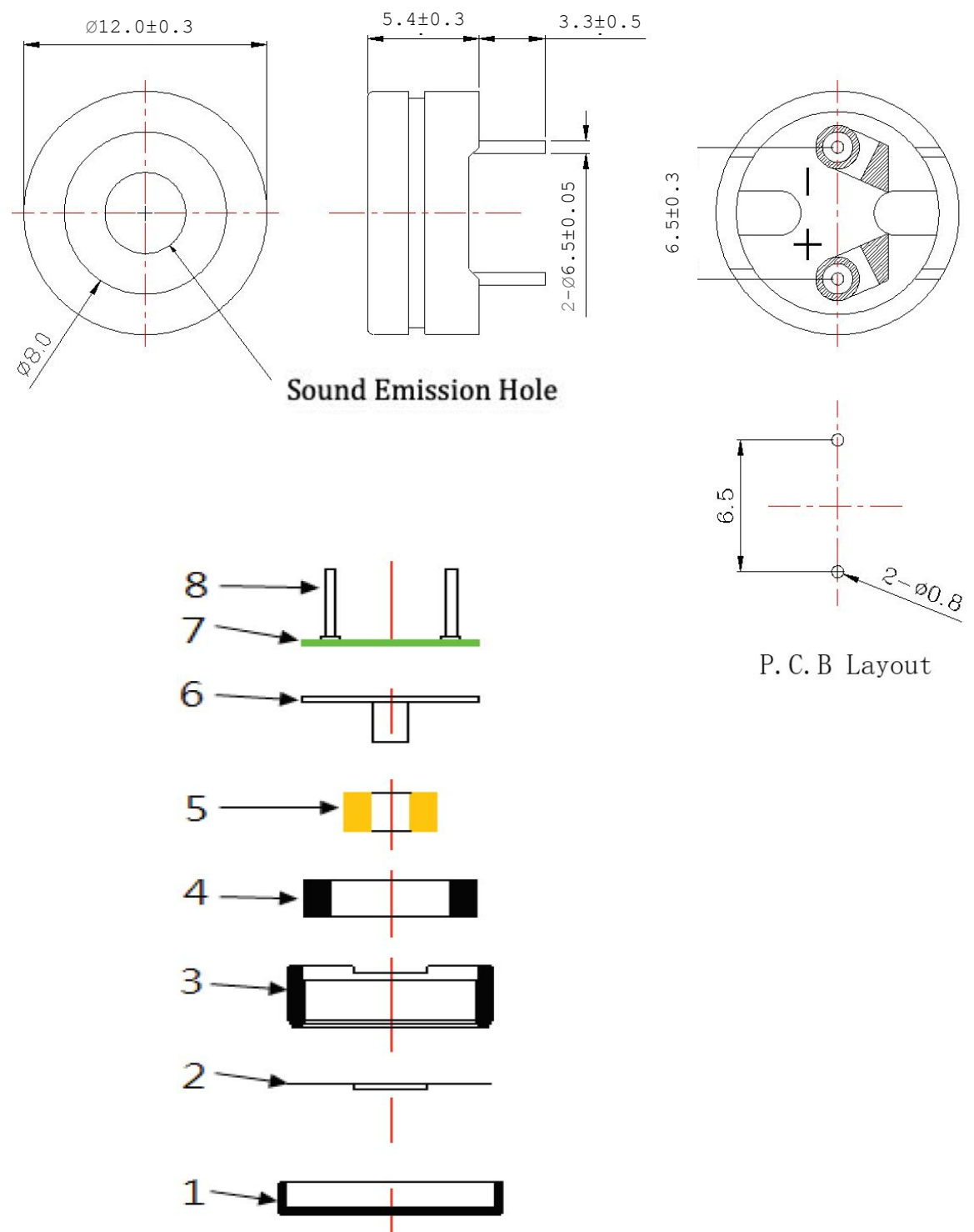

No.	Part Name	Material	Quantity
1	Cover	PPO	1
2	Diaphragm	Iron	1
3	Base	PPO	1
4	Magnet	NdFeB	1
5	Coil	Copper	1
6	Core	Iron	1
7	PCB	Epoxy Glass Fiber Cloth + Copper	1
8	PIN	Copper	2



soberton inc.

GT MAGNETIC BUZZER

Acoustic Product Specification

Product Number: GT-111PS-1



Release | Revision: C/2018

CONTENTS

This document contains the technical specifications for the electromagnetic buzzer.

Page 1

Specifications

Mechanical Characteristics

Page 2

Environment Test

Reliability Test

Page 3

Recommended Temperature Profile

Measurement Test Circuit

Inspection Fixture

Page 4

Frequency Response Curve

Page 5

Dimensions

Page 6

Packing

Packing

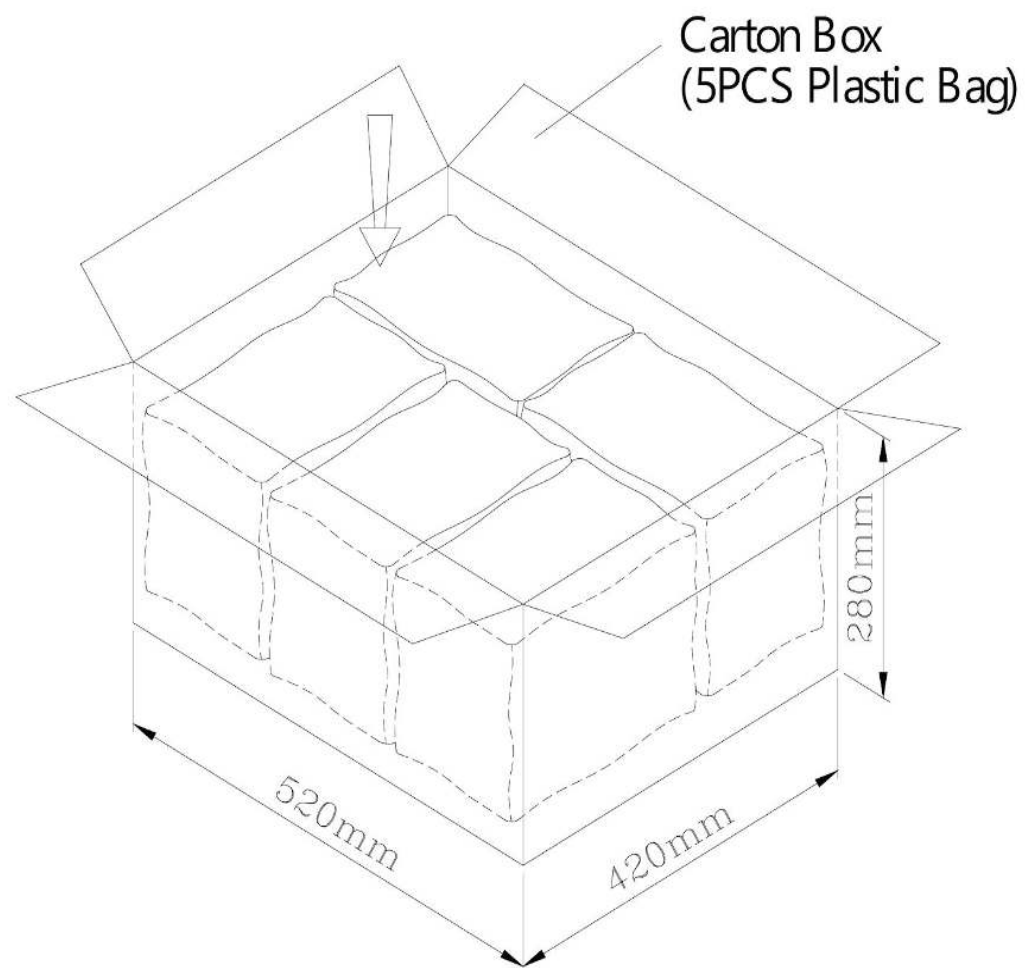
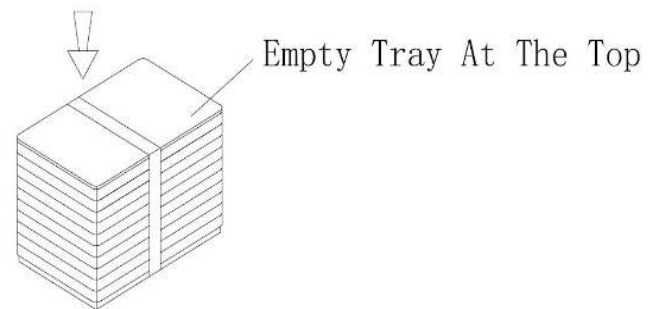
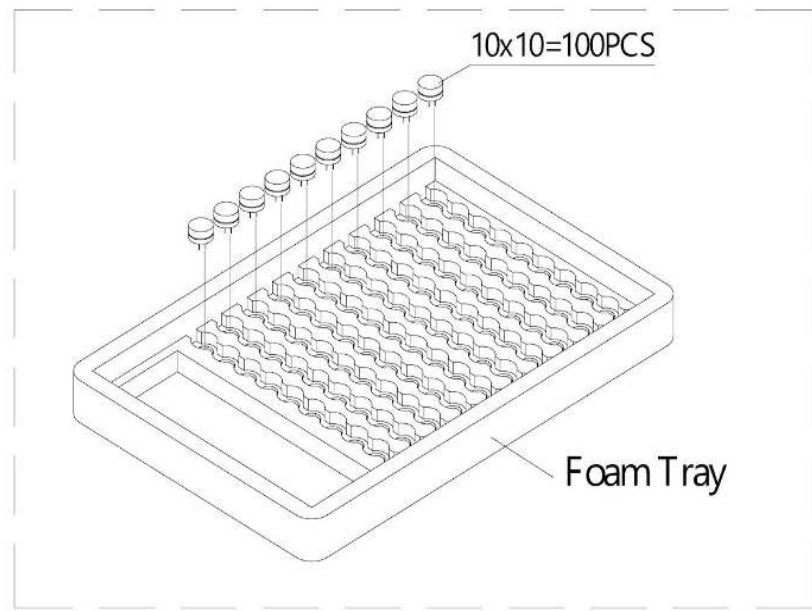

Packing Box	L x W x H (mm)	Pieces
Foam Tray	240 x 160 x 30	1 x 100PCS = 100PCS
Plastic Bag		10 x 100PCS = 1,000PCS
Carton Box	520 x 420 x 280	5 x 1,000PCS = 5,000PCS