

PRODUCT NUMBER	COLOR	LENGTH
10152943-Z0500YBLF	BLACK	500
10152943-Z0500YGLF	COOLGREY 9C	
10152943-Z0500YWLF	WHITE	

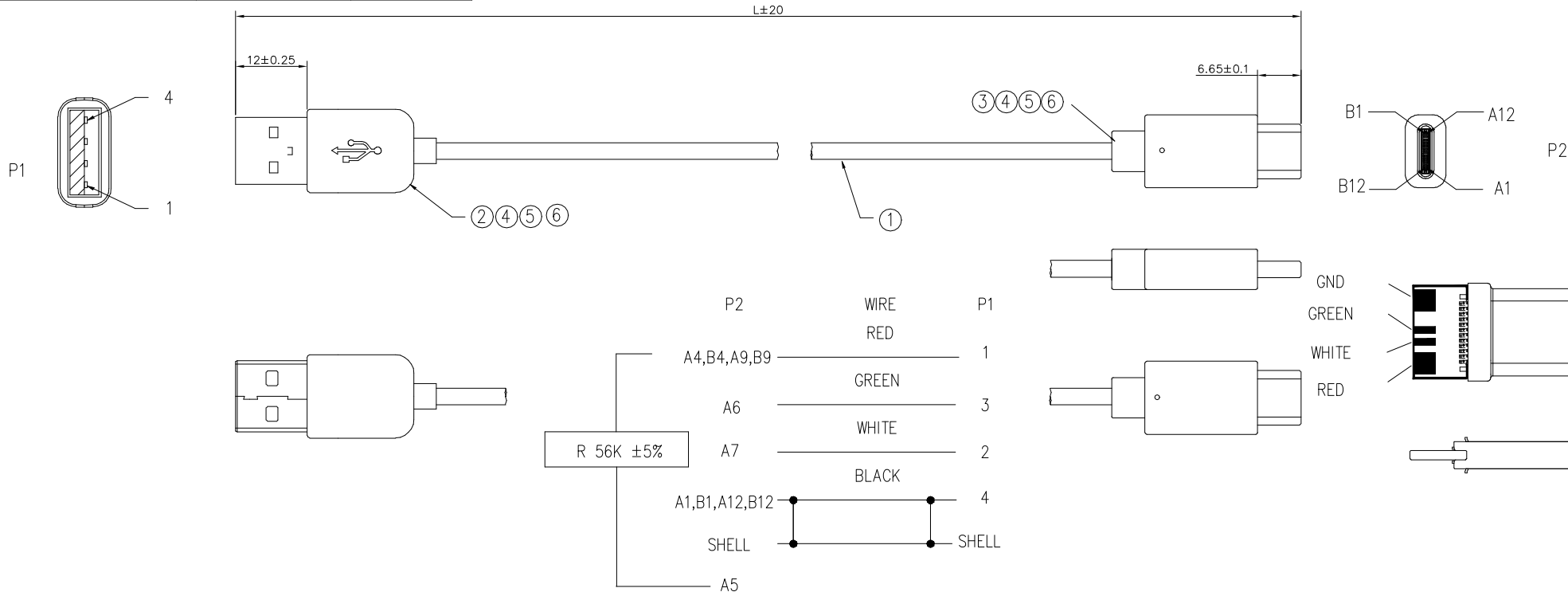

ELECTRICAL TEST

- 100% OPEN, SHORT & INTERMITTANCE TEST
- INSULATION RESISTANCE: 10MΩ Min.
- HI-POT: DC 300V/10ms
- CONDUCTOR RESISTANCE:

CONDUCTOR RESISTANCE FOR Vbus: 1.5Ω Max
 CONDUCTOR RESISTANCE for GND: 1.5Ω Max

5. PRODUCT REFER TO GS-12-1577

A/R	KG	Description	Item
A/R	KG	Ø 8MM SOLDER WIRE L/F	6
A/R	KG	OVER MOLDED: BLACK/COOL GREY 9C TPE,WHITE	5
A/R	KG	INNER MOLDED: PP	4
1	EA	USB TYPE-C PLUG: SHELL Ni PLATING , HOUSING: WHITE, PCB: 56KΩ RESISTOR	3
1	EA	USB2.0 A/M: SHORT TYPE, HOUSING: WHITE, SHELL: Ni PLATING SALT SPRAY 24H	2
A/R	M	NO UL 30AWG*1P +24WG*2C+AL JACKET OD: 3.5MM, TPE/COOL GREY 9C ,BLACK ,WHITE	1
Qty	Unit	Description	Item
mat'l. code		surface ISO 1302 ✓ tolerance ISO 406 ISO 1101	projection
A /		tolerances unless otherwise specified	product family Cable Assembly
B N-36968		angles linear .000 ±0.15 .00 ±0.35 .0 ±0.5	title USB Cable Round Type A - Type C
dr St		5 /06'20	MM
enr St		5 /06'20	scale N/A
chr Tim Yao		5 /06'20	Amphenol FCI
appd Tim Yao		5 /06'20	dwg no 10152943 sheet 1 of 3 size A3
sheet revision B			type Customer Drawing
index sheet 3			

Amphenol FCI

© 2016 AFCI

PRODUCT NUMBER	COLOR	LENGTH/"L"
10152943-Z0100YBLF	BLACK	1000
10152943-Z0100YGLF	COOLGREY 9C	
10152943-Z0130YWLF	WHITE	
10152943-Z0130YGLF	COOLGREY 9C	1270
10152943-Z0130YBLF	BLACK	
10152943-Z0130YWLF	WHITE	

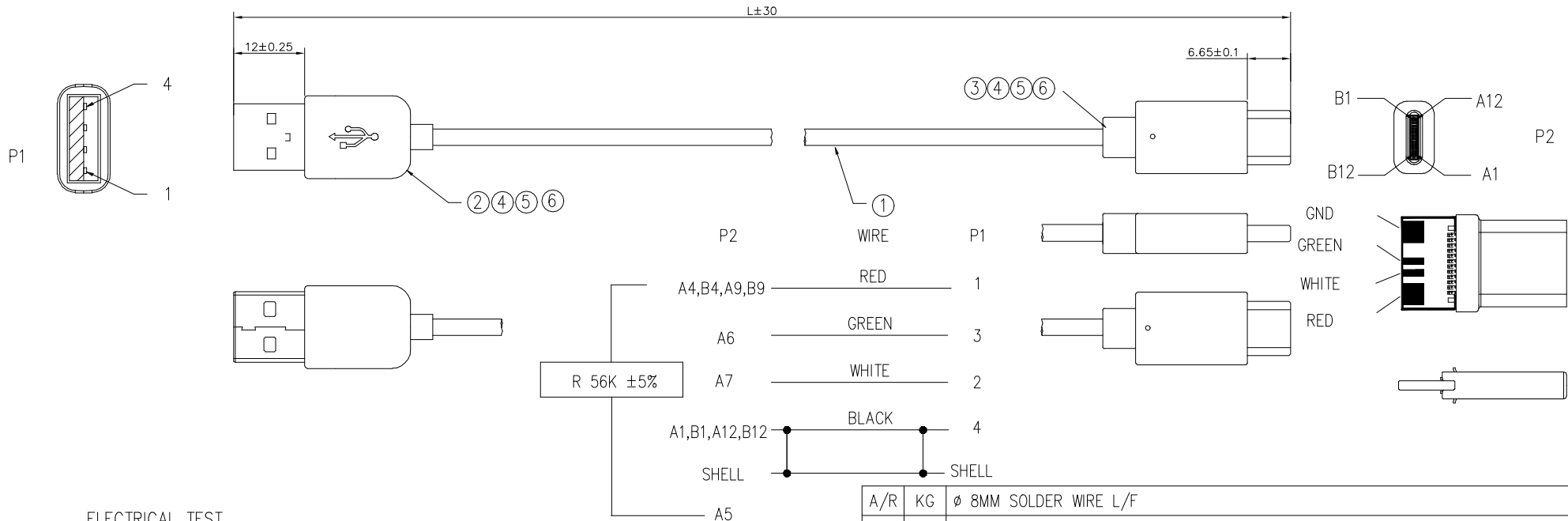

ELECTRICAL TEST

- 100% OPEN, SHORT & INTERMITANCE TEST
- INSULATION RESISTANCE: 10MΩ Min.
- HI-PORT: DC 300V/10ms
- CONDUCTOR RESISTANCE: 1.5Ω Max

A/R	KG	Description	Item
A/R	KG	Ø 8MM SOLDER WIRE L/F	6
A/R	KG	OVER MOLDED: BLACK/COOL GREY 9C ,WHITE TPE	5
A/R	KG	INNER MOLDED: LD-PE	4
1	EA	USB TYPE-C PLUG: SHELL Ni PLATING , HOUSING: WHITE, PCB: 56KΩ RESISTOR	3
1	EA	USB2.0 A/M: SHORT TYPE, HOUSING: WHITE, SHELL: Ni PLATING SALT SPRAY 24H	2
A/R	M	NO UL 30AWG*1P +24WG*2C+AL JACKET OD: 3.5MM, TPE BLACK/COOL GREY 9C, WHITE	1
Qty	Unit	Description	Item
mat'l. code		surface ISO 1302 ✓ tolerance ISO 406 ISO 1101	projection
A /		tolerances unless otherwise specified	product family Cable Assembly
B N-36968		angles linear .000 ±0.15 .00 ±0.35 .0 ±0.5	title USB Cable Round Type A - Type C
dr St 1 /7'19		±3'	MM
enr St 5 /06'20		scale N/A	dwg no 10152943 sheet 2 of 3 size A3
chr Tim Yao 5 /06'20		Amphenol FCI	type Customer Drawing
appd Tim Yao 5 /06'20			
sheet index	revision sheet	B 3	

Amphenol FCI

© 2016 AFCI

©

D

PRODUCT NUMBER

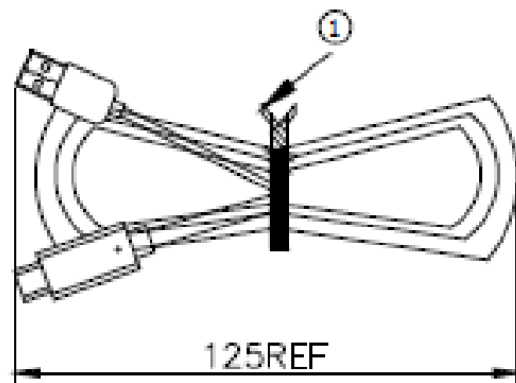

1.Package for 1PC

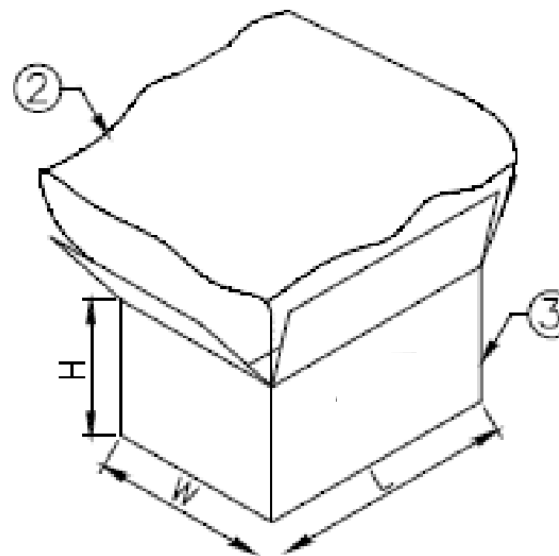

2.500PCS/WATERPROOF BAG+CARTON

NOTE:

1. PACKAGE IS JUST FOR REFERENCE ONLY,CAN BE CUSTOMIZED.

1	EA	CARTON 500*395*290		3	
1	EA	WATERPROOF BAG		2	
A/R	M	CABLE TIE		1	
Qty	Unit	Description		Item	
mat'l. code		surface ISO 1302	tolerance ISO 406 ISO 1101	projection	product family Cable Assembly
ltr	ecn no	dr	date	tolerances unless otherwise specified	title
A	/	St	1 /7'19	angles	USB Cable Round Type A - Type C
B	N-36968	St	5 /06'20	linear	
				±.3'	scale N/A
				dr St 5 /06'20	dwg no 10152943 sheet 3 of 3 size A3
				enr St 5 /06'20	
				chr Tim Yao 5 /06'20	
				appd Tim Yao 5 /06'20	
sheet index	revision sheet	B	3	type Customer Drawing	

Amphenol FCI

© 2016 AFCI

©

©