

Material:

* Insulation:

Base & Cover: Glass Filled Polyester UL 94V-0

* Contact: Phosphor Bronze

* Accommodated Cables:

1.27mm(.050")Center spacing Flat

Cable Insulator O.D.: 0.85 mm dia.

* Construction: AWG #28 (7/0.127mm)

Ordering Code:

CA30 ** P 1 3 I *
① ② ③ ④ ⑤ ⑥ ⑦

① Series No.:

② No. of Circuits: 04 to 26

③ Contacts Type: P= Pin Header

④ Plating option:

1= Tin over Nickel plated
(Matte Tin plated)

⑤ Color: 3= Red

⑥ Type: I = IDC Type

⑦ Option: 0= Standard (Tube Packing)
R= Tape & Reel Packing

DIM.A= 1.27 x No. of Spaces

DIM.B= DIM.A + 3.3

DIM.C= DIM.A + 2.1

DIM.D= DIM.A + 4.7

*Available in 4 ~ 26 Circuits

RoHS Compliant

④	Sun	3/11-16'	ECRT116009/ECNT116035		DATE	UNIT: mm / inch	TITLE: 1.27mm Pitch Male IDC Type Connector	 瀚荃股份有限公司 CviLux Corporation
③	Una	11/11-10'	ECN10365	DRAWN BY: Sun	3/14-16'	TOLERANCE UNLESS OTHERWISE SPECIFIED	MATERIAL:	
②	Sun	11/19-09'	ECN09528	ENGINEER: Sun	3/14-16'	.X ± 0.30/.012 X' ± 1'	FINISH:	PART NO. CA30**P13I*
①	Hank	3/12-09'	ECN09122	CHECKED BY: Eisley	3/15-16'	.XX ± 0.20/.008 .X' ±		SCALE 4 / 1
SYM	NAME	DATE	REVISIONS	APPROVED BY: Eisley	3/15-16'	.XXX ± 0.10/.004 .XX' ±		

 2016.03.17
 ISSUED

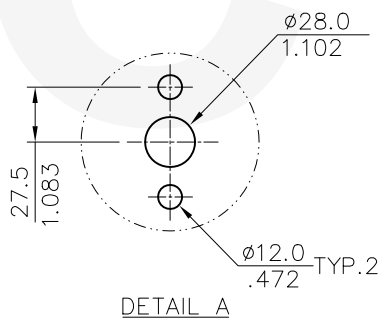
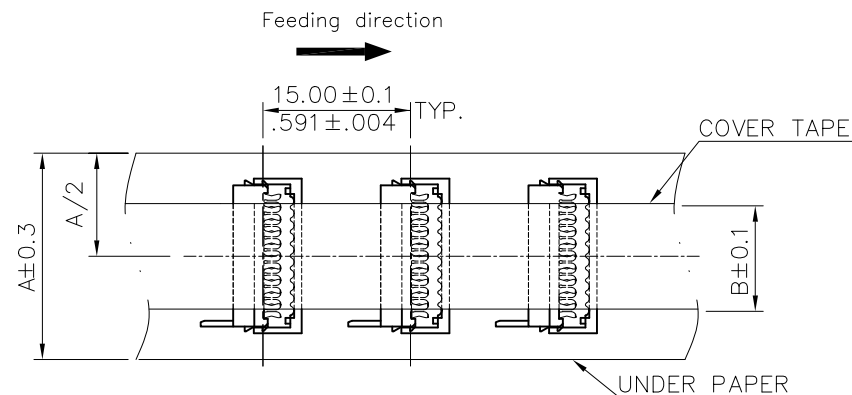
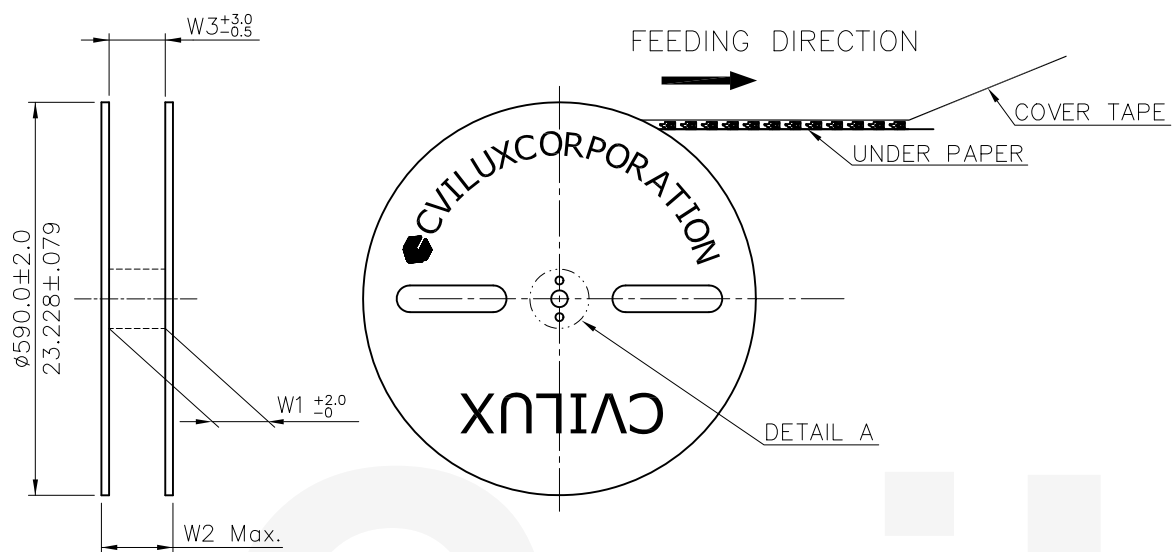

Circuits	Dimension				
	A	B	W1	W2	W3
4	11.0(.433)	6.0(.236)	13.0(.512)	23.0(.906)	13.0(.512)
6	17.0(.669)	6.0(.236)	18.0(.709)	28.0(1.102)	18.0(.709)
8	17.0(.669)	6.0(.236)	18.0(.709)	28.0(1.102)	18.0(.709)
10	21.0(.827)	6.0(.236)	22.0(.866)	32.0(1.260)	22.0(.866)
12	21.0(.827)	6.0(.236)	22.0(.866)	32.0(1.260)	22.0(.866)
14	24.0(.945)	6.0(.236)	25.0(.984)	35.0(1.378)	25.0(.984)
16	29.0(1.142)	6.0(.236)	30.0(1.181)	40.0(1.575)	30.0(1.181)
18	29.0(1.142)	6.0(.236)	30.0(1.181)	40.0(1.575)	30.0(1.181)
20	32.0(1.260)	6.0(.236)	33.0(1.299)	43.0(1.693)	33.0(1.299)
22	36.0(1.417)	6.0(.236)	37.0(1.457)	47.0(1.850)	37.0(1.457)
24	36.0(1.417)	6.0(.236)	37.0(1.457)	47.0(1.850)	37.0(1.457)
26	39.0(1.535)	6.0(.236)	40.0(1.575)	50.0(1.969)	40.0(1.575)

* Quantity : 2500 PCS/Reel/Caton

4	Sun	3/11-16'	ECRT116009/ECNT116035	DATE	UNIT: mm / inch	TITLE: TAPE & REEL PACKAGING FOR CA30 SERIES SMT TYPE		 瀚荃股份有限公司 CviLux Corporation			
3	Una	11/11-10'	ECN10365	DRAWN BY: Sun	3/14-16'						
2	Sun	11/19-09'	ECN09528	ENGINEER: Sun	3/14-16'	MATERIAL:		DRAWING NO. CA3001SE		PART NO.	CA30**P13I*
1	Hank	3/12-09'	ECN09122	CHECKED BY: Eisley	3/15-16'	FINISH:		SCALE		SHEET 2 OF 2	
SYM	NAME	DATE	REVISIONS	APPROVED BY: Eisley	3/15-16'	.X ±	.X' ± 1'				
						.XX ±	.X' ±				
						.XXX ±	.XX' ±				

