

THIS COPY IS PROVIDED ON A RESTRICTED BASIS AND IS NOT TO BE USED IN ANY WAY DETRIMENTAL TO THE INTERESTS OF PANDUIT CORP.

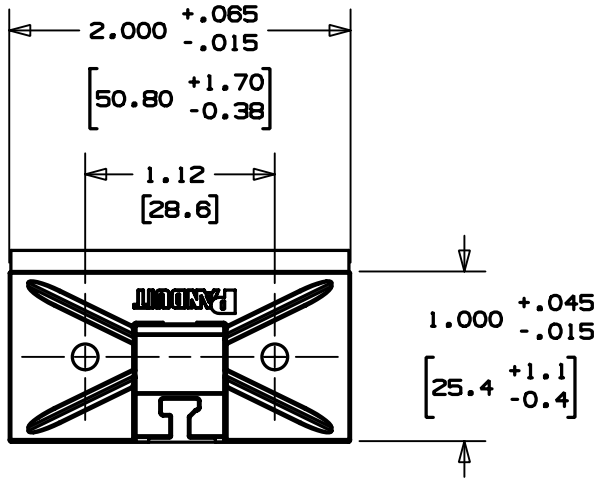

PANDUIT PART NO. *	REC'M FASTENER	USE WITH THESE CABLE TIES **	WEIGHT lbs 100 (g) pcs
SMS-A	-----	S = STANDARD	0.81 (371)
SMS-S6	#6 F.H.C.S or B.H.C.S		0.74 (335)

- TO APPLY ADHESIVE MOUNT:**
1. REMOVE PROTECTIVE LINER.
  2. PLACE IN DESIRED LOCATION.
  3. APPLY PRESSURE TO TOP SURFACE OF MOUNT.

- NOTES:**
1. SEE CURRENT PRICE SHEET FOR PART NUMBER SUFFIX DESIGNATION FOR PACKAGE SIZE AND COLOR.

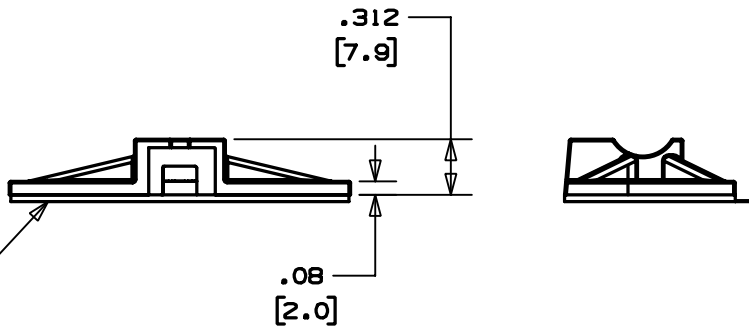

ADHESIVE BACKING:  
PRESSURE SENSITIVE FOAM TAPE 0.040" (1.0)  
THICK WITH PROTECTIVE LINER. MOUNT IS DESIGNED  
TO SUPPORT 11b. (454g) MAX. WEIGHT ON A  
CLEAN DRY, SMOOTH, GREASE-FREE SURFACE.

NO WARRANTY, EXPRESSED, OR IMPLIED, IS MADE BY PANDUIT WITH RESPECT TO ADHESIVE BOND PERFORMANCE. AMONG OTHER THINGS, THE CONDITIONS UNDER WHICH THESE MOUNTS MAY BE APPLIED AND/OR THE SURFACE TO WHICH THEY MAY BE APPLIED ARE BEYOND PANDUIT'S CONTROL.

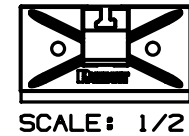
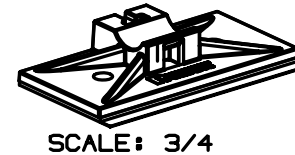

DIMENSIONS IN BRACKETS ARE METRIC [ mm ]			
CAD FILENAME/LAYERS: G00239LA_PB_SMS_00			
<b>PANDUIT</b> CORP.		TINLEY PARK, ILLINOIS	
SNAP IN MOUNT (SMS-A, -S6)			
UNLESS OTHERWISE SPECIFIED, DIMENSIONAL TOLERANCES ARE: (.X) ±0.05 (1.3) (.XXX) ±0.010 (0.25) (.XX) ±0.02 (0.5) ANGLES ± 5°		UNLESS OTHERWISE SPECIFIED, ALL DIMENSIONS ARE GIVEN IN INCHES, THIRD ANGLE PROJECTION.	
DRAWN BY: JAD	MAT'L: ABS	SCALE: FULL	
DATE: 1/28/04		DRAWING NO.: GB0239LA	DWG SIZE: A
CR'D			

REV	DATE	BY	CHK	DESCRIPTION	ECN - R	CUST	SUP
R	1/28/04	JAD		INITIAL RELEASE	GB0239LA	R	