

- 1 BROWN
- 2 WHITE
- 3 BLUE
- 4 BLACK

FACE VIEW-MALE INSERT

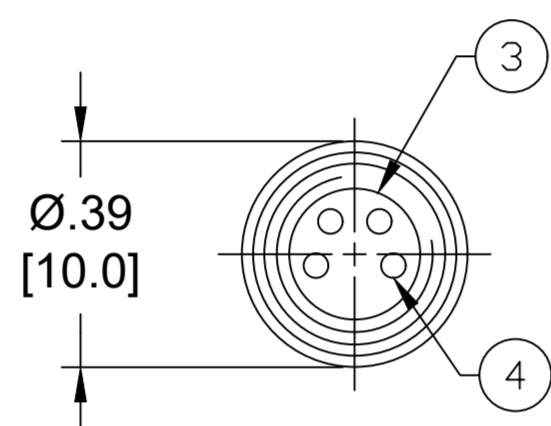

- NOTES:**
1. MATERIAL: AS NOTED
 2. FINISH: AS NOTED
 3. ELECTRICAL:
VOLTAGE : 60VAC/75VDC
CURRENT: 4A
 4. TEMP RATING: -20° TO +105°C (B)
 5. PROTECTION: IP67 (WHEN MATED)
 6. UL LISTED FILE: E152210 (B)
 7. ALL DIMENSIONS ARE FOR REFERENCE UNLESS TOLERANCED OR NOTED OTHERWISE

MECHANICAL CHARACTERISTICS:

TORSIONAL FLEX TEST	10 MILLION CYCLES PER MIL-C-13777G
BEND FLEX TEST	10 MILLION CYCLES PER MIL-C-13777G
WELD SLAG RESISTANCE	WOODHEAD STANDARD S-300

ITEM	COMPONENT	MATERIAL	FINISH
7	LABEL	VINYL	BLACK/YELLOW
6	MALE SLEEVE	BRASS	COPPER/NICKEL
5	COUPLER	BRASS	NICKEL PLATED
4	CONTACT	COPPER ALLOY	GOLD OVER NCKEL
3	INSERT	TPU	BLACK
2	OVERMOLD	TPC	YELLOW
1	CABLE #22-4 AWG	TPE JACKET	YELLOW

MATERIAL NUMBER	ENGINEERING NUMBER	FINISHED LENGTH
1200868534	404006K05M010	1M [3 FT 3 IN]
1200868535	404006K05M020	2M [6 FT 7 IN]
1200868536	404006K05M050	5M [16 FT 5 IN]
1200868537	404006K05M100	10M [32 FT 10 IN]

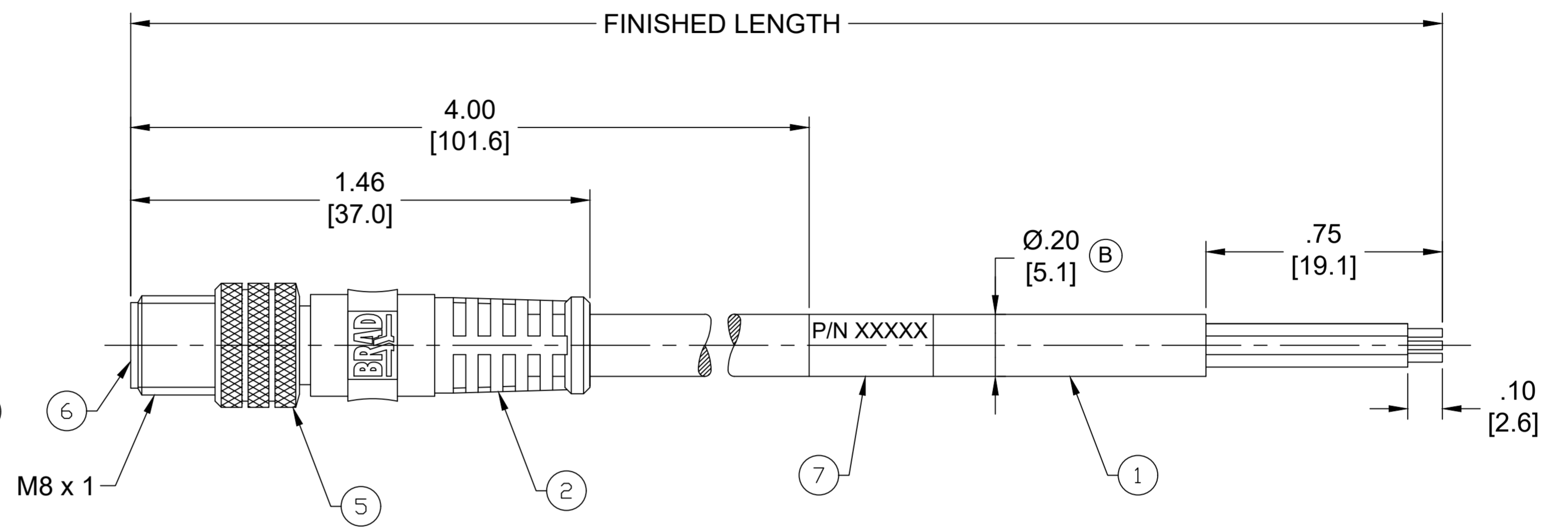

**PART NO. MATRIX
404006K05M010**

LENGTH
M001 = .1 METER
M010 = 1 METER
M100 = 10 METER
PRE-RELEASED FOR REFERENCE USE ONLY

(B)

CABLE LENGTH TOLERANCES

- <.3M [1FT]: +19mm-0 [+.75in-0]
- .3 - .9M [1 - 3FT]: +44.5mm-0 [+1.75in-0]
- .9 - 1.8M [3 - 6FT]: +55.6mm-0 [+2.19in-0]
- 1.8 - 3.7M [6 - 12FT]: +88.9mm-0 [+3.50in-0]
- 3.7 - 7.3M [12 - 24FT]: +165.1mm-0 [+6.50in-0]
- 7.3-14.6M [24 - 48FT]: +317.5mm-0 [+12.50in-0]
- 14.6 - 30.5M [48-100FT]: +622.3mm-0 [+24.50in-0]
- OVER 30M [100FT] +2% OF FINISHED LENGTH

THIS DRAWING CONTAINS INFORMATION THAT IS PROPRIETARY TO MOLEX ELECTRONIC TECHNOLOGIES, LLC AND SHOULD NOT BE USED WITHOUT WRITTEN PERMISSION

FUNCTIONAL SYMBOLS	DIMENSION UNITS	SCALE	CURRENT REV DESC: ITEM #2 WAS TPE, 3 WAS PUR & 7 WAS MYLAR. ADDED ITEM #6, TOL CHART & CABLE DIA. MODIFIED TEMP RATING & PN CHART. REMOVED CSA
FA=0	INCH/MM	NTS	
FC=0	GENERAL TOLERANCES (UNLESS SPECIFIED)		
FP=0	mm	INCH	
DIVISIONAL SYMBOLS	4 PLACES	±----	EC NO: 666551
	3 PLACES	±----	DRWN: ABENJAMINLW 2021/04/08
	2 PLACES	±----	CHK'D: RSTONE 2021/06/10
	1 PLACE	±----	APPR: ----
	0 PLACES	±----	INITIAL REVISION:
	ANGULAR TOL ± ---- °		DRWN: GGUSTAFS 2013/10/10
	DRAFT WHERE APPLICABLE MUST REMAIN WITHIN DIMENSIONS	THIRD ANGLE PROJECTION	APPR: BWOODMAN 2013/11/20
		DRAWING C-SIZE	SERIES 120086
		MATERIAL NUMBER	CUSTOMER
		SEE CHART	GENERAL MARKET
			SHEET NUMBER 1 OF 1

molex

NANO-CHANGE CORDSET
4 POLE, MALE, STRAIGHT, #22 AWG TPE

PRODUCT CUSTOMER DRAWING

DOCUMENT NUMBER: SD-120086-051
DOC TYPE/DOC PART/REVISION: PSD 001 B