

4

3

2

1

THIS DRAWING IS UNPUBLISHED. RELEASED FOR PUBLICATION 20
 © COPYRIGHT 20 BY TYCO ELECTRONICS CORPORATION. ALL RIGHTS RESERVED.

LOC	DIST	REVISIONS			
P	LTR	DESCRIPTION	DATE	DWN	APVD
ES	00	A1	RELEASED PER ECR-09-002836	12FEB2009	S.W S.Y
		A2	RELEASED PER ECR-09-005272	2MAR2009	S.W S.Y
		B	REVISED TO ADD *-3	24SEP2013	E.L WK.H
		B1	OBSOLETE	05JUN2019	K.G W.H

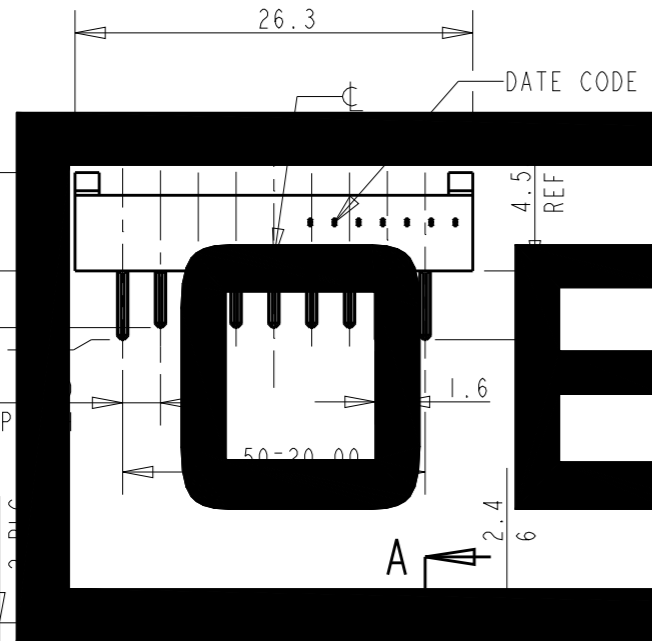
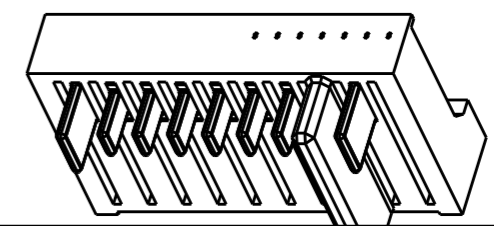
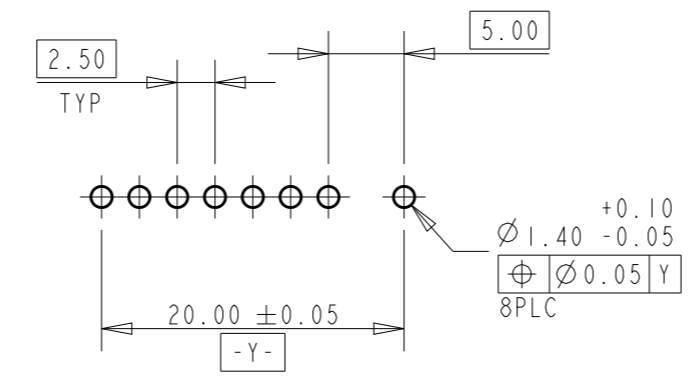
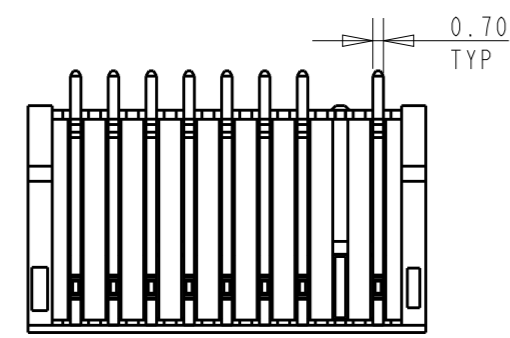

REFERENCE P.C. BOARD LAYOUT
 P.C. BOARD THK 0.8-1.2
 (VIEW FROM CONNECTOR MOUNTING SIDE)

OBSOLETE

PART NUMBER: -1/-3 AS SHOWN

1 MATERIAL
 HOUSING: THERMOPLASTIC RESIN, BLACK, UL V-0

2 FINISH
 CONTACT: Ni ALL OVER UNDER PLATING.
 GOLD PLATING AT CONTACT AREA.
 GOLD FLASH PLATING AT SOLDER AREA.

2.7	9.6	10.2	7.2	1932123-3
2.7	9.6	10.2	7.2	1932123-2
3.5	14.4	15	12	1932123-1
NET WEIGHT	DIM.N	DIM.M	DIM.L	PART NUMBER

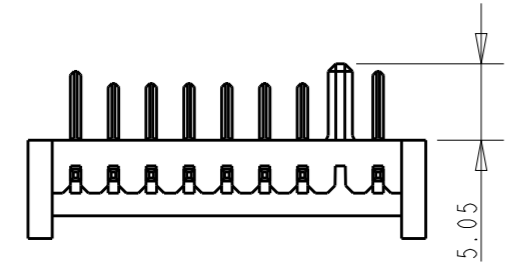
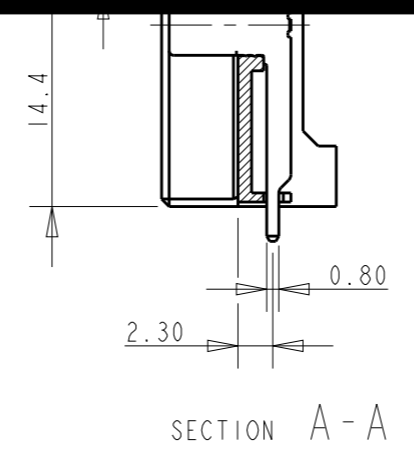

THIS DRAWING IS A CONTROLLED DOCUMENT FOR TYCO ELECTRONICS CORPORATION. IT IS SUBJECT TO CHANGE AND THE CONTROLLING ENGINEERING ORGANIZATION SHOULD BE CONTACTED FOR THE LATEST REVISION.		DWN T. YU 03JUL2008	Tyco Electronics Shanghai P.R.CHINA 200233	
DIMENSIONS: mm		CHK S. ZHAO 03JUL2008		
TOLERANCES UNLESS OTHERWISE SPECIFIED:		APVD S. YAO 03JUL2008	NAME PLUG ASSEMBLY 2.5mm PITCH BATTERY CONNECTOR CENTER HEIGHT=12.0mm	
0 PLC ± 1 PLC ±0.25 2 PLC ±0.10 3 PLC ± 4 PLC ± ANGLES ±3°		PRODUCT SPEC -	RESTRICTED TO	
MATERIAL 1		APPLICATION SPEC -	SIZE A3	CAGE CODE 00779
FINISH 2		WEIGHT 3.5g	DRAWING NO 1932123	
		CUSTOMER DRAWING	SCALE 2:1	SHEET 1 OF 1 REV B1