

SINGLE THRU HOLE IDC CONTACT

12-18 AWG: 9177-600



General Information



KYOCERA AVX developed the initial SMT discrete wire IDC connector 5 years ago for 26-28AWG wires. Since then, we have seen this Wire-to-Board (WTB) contact technology spread to multiple wire gauges and multiple configurations; standard connectors, capped connectors and single contacts. All of which addresses specific application or cost parameters set forth by our customer in demanding industrial, transportation or commercial applications. The heart of the IDC connector is the true “gas tight” WTB termination that is achieved once the wire is inserted between the dual phosphor bronze contact tines. These opposing tines provide enough spring characteristics to allow the termination to remain stable over extreme levels of temperature, shock and vibration.

The new 9177-600 family of contacts incorporates all of the above mentioned capabilities. From low cost single contacts to fully integrated capped contacts. The unique feature of the 600 series is the fact that it was developed for Plated Through Hole (PTH) termination to the PCB. This addresses the rugged power type boards that have to handle larger wire gauges up to 12AWG and 15 Amps per contact of current. The PTH option provides robust PCB attachment and high current capabilities to replace older technology connectors or in most cases soldering stripped wires directly to the PCB.

APPLICATIONS

- Industrial pumps, motors and driver boards
- Solar and alternative energy products
- Commercial electrical equipment
- Reference Product Specification & application notes 201-01-141/142

FEATURES AND BENEFITS

- IDC contact provides a “gas tight” wire termination to the PCB to meet harsh industrial environments
- Simple, robust design offers a high performance solution to hand soldering large gauge wires to a PCB
- A single contact can handle up to 15A for high current applications with wire replacement up to 3 times
- The versatile family of IDC contact can accept 12-18AWG of stranded wires and can be tested for compliance with solid wires

ELECTRICAL

- Current Rating: 15A
- Voltage Rating: 600 VAC

ENVIRONMENTAL

- Operating Temperature: -40°C to +125°C

MECHANICAL

- Insulator Material: Nylon 46, UL94V0
- Contact Material: Phosphor Bronze
- Plating: Tin over Nickel
- Durability: Wires can be replaced up to 3 time

HOW TO ORDER – CONTACT OPTIONS

70
Prefix
70 = Contact

9177
Series

001
Number of Ways

Code	No of Ways	Details
001	1	Page 72

6XX
Wire Gauge Size

Code	Accepted Wire Gauge
691	12 AWG Solid or Stranded
601	14 AWG Solid or Stranded
612	16 AWG Solid or Stranded
622	18 AWG Solid or Stranded

006
Plating Option
006 = Pure Tin all Over



HOW TO ORDER – CAP OPTIONS

60
Prefix
60 = Cap

9177
Series

001
Number of Ways

Code	No of Ways	Details
001	1	Pages 74-75

6XX
Wire Insulation Diameter

Code	Wire Insulation (AWG)	Diameter "A"
627	Ø 2.10 - 2.75	2.75
635	Ø 2.75 - 3.50	3.50
642	Ø 3.50 - 4.25	4.25

X
Color Options

Code	Color	Application
0	Black	Special Order
1	White	Standard

XX
Assembly Options

Code	Description
00	Through Wire
99	With Stop

SINGLE THRU HOLE IDC CONTACT

12-18 AWG: 9177-600



Contact Details

70-9177-001-6XX-006
CONTACT DETAILS

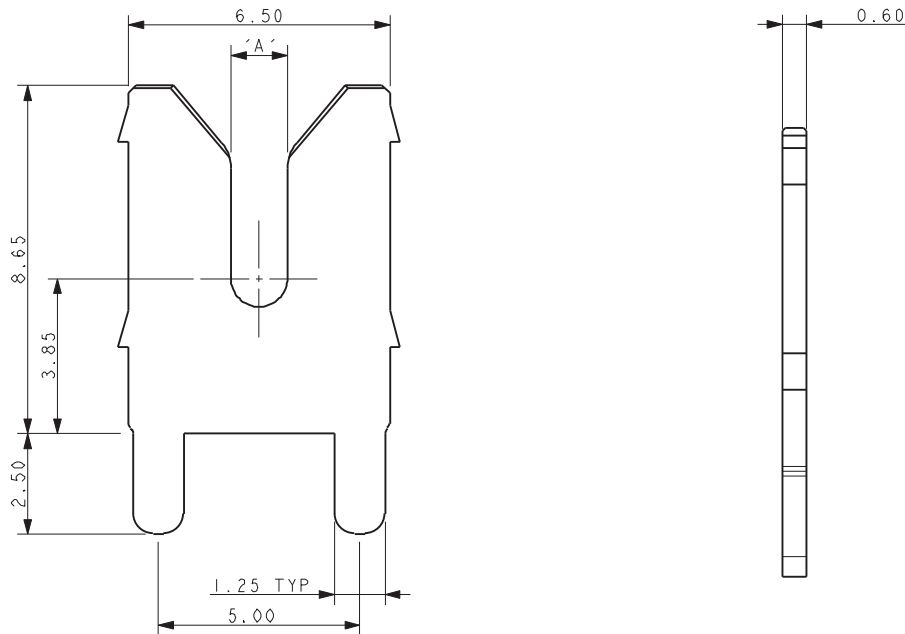

PCB LAYOUT FOR CONTACT

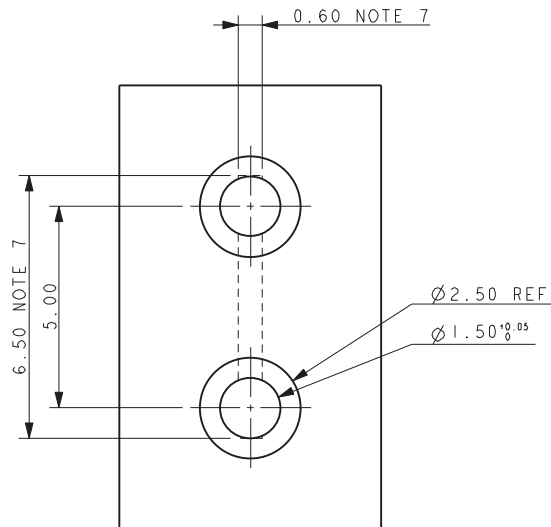

Code	Accepted Wire Gauge	A
691	12 AWG Solid or Stranded	1.50
601	14 AWG Solid or Stranded	1.10
612	16 AWG Solid or Stranded	0.82
622	18 AWG Solid or Stranded	0.72

NOTES:

1. IDC CONTACT OT ACCEPT WIRES FROM 12 AWG TO 18 AWG.
2. MATERIAL: PHOSPHOR BRONZE.
3. PLATING PURE TIN OVER NICKEL.
4. ALL DIMENSIONS ± 0.20 UNLESS SPECIFIED.
5. PACKING IN BAGS, 800 PIECES PER BAG.
6. PRODUCT SPECIFICATION REFER TO 201-01-141.
7. OUTLINE OF CONTACT SEE PAGE 71 FOR ADDITIONAL CLEARANCE REQUIRED FOR WIRE INSERTION TOOL.
8. FOR ASSEMBLY DETAILS REFER TO APPLICATION NOTES 201-01-142.

SINGLE THRU HOLE IDC CONTACT

12-18 AWG: 9177-600

Assembly Tooling

ASSEMBLY TOOLING

Part Number	Wire Insulation	A
06-9177-7021-01-000	Ø 3.50 - 4.25	425
06-9177-7021-02-000	Ø 3.50 - 4.50	350
06-9177-7021-03-000	Ø 3.50 - 2.75	275

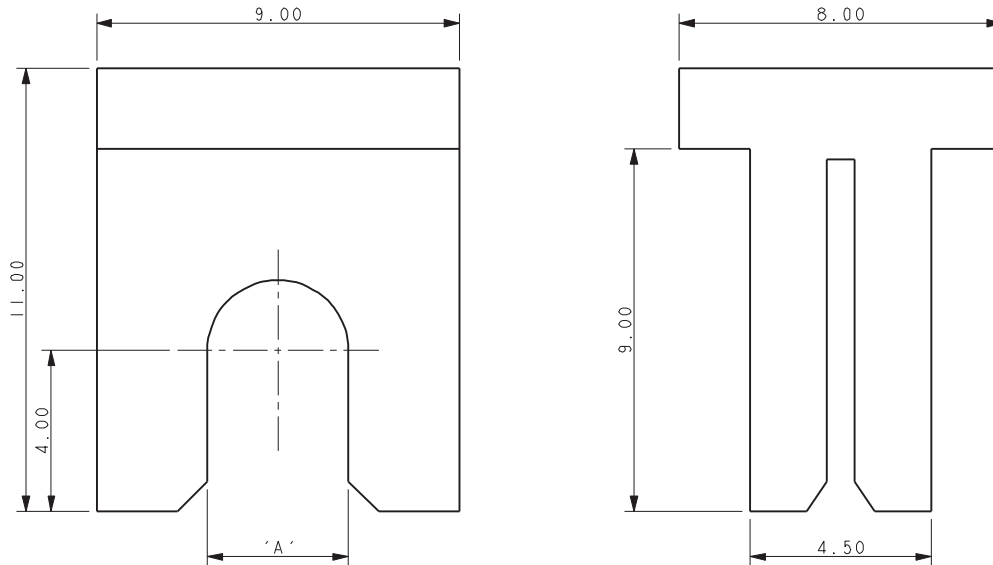

NOTES:

1. WIRE INSERTION TOOL 06-9177-7021-0X-000, FULL PART NUMBER REFER TO TABLE.
2. TOOL PART NUMBER DEPENDENT ON WIRE INSULATION DIAMETER NOT WIRE GAUGE OR CONTACT NUMBER.
3. ASSEMBLY DETAILS REFER TO APPLICATION NOTES 201-01-142
4. MATERIAL: TOOL STEEL.
5. APACE REQUIRED ON PCB FOR TOO. NO COMPONENTS IN THIS AREA.

PCB CLEARANCE AREA FOR TOOL

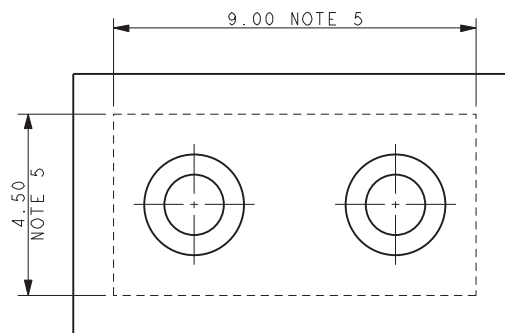

SINGLE THRU HOLE IDC CONTACT

12-18 AWG: 9177-600

Accessory Cap - Through Wire



60-9177-001-6XX-X00 1 WAY WIRE THROUGH CAP DETAILS

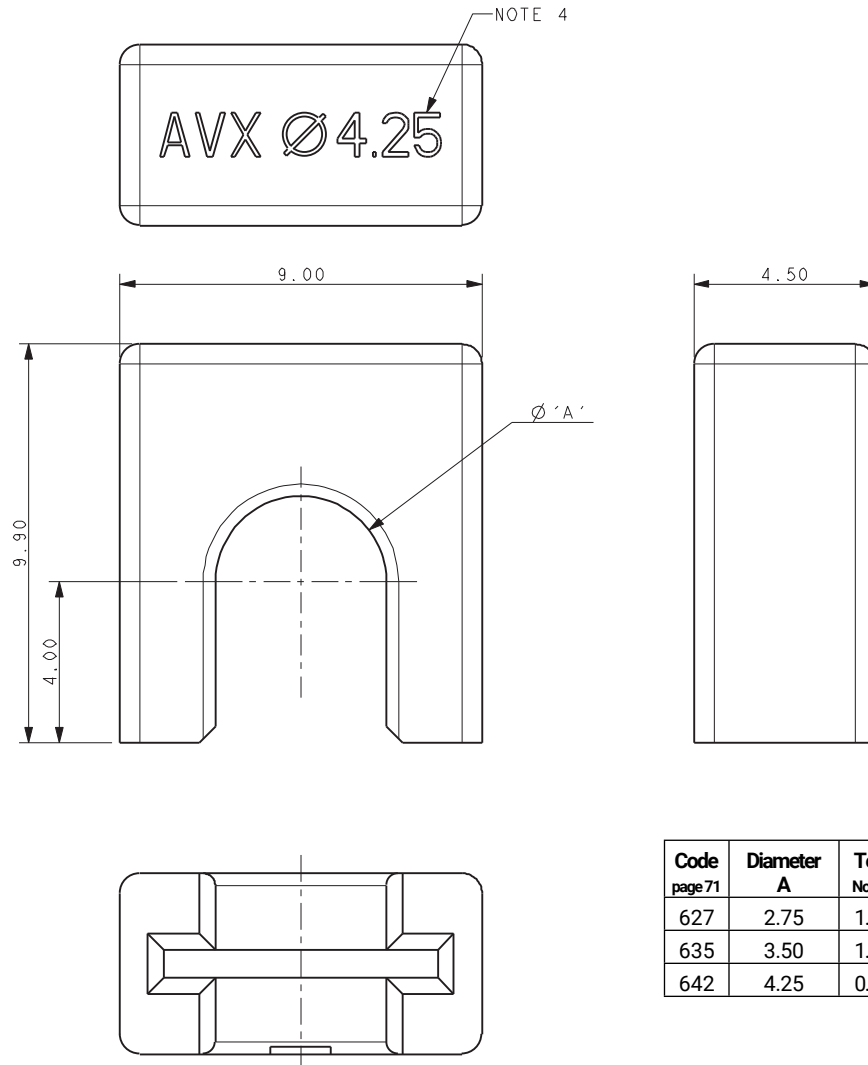

NOTES:

1. CAP FOR IDC WIRE TO BOARD CONNECTION, 1 WAY WITH THROUGH WIRE.
2. WIRE THROUGH CAP FOR ASSEMBLY AT ANY POSITION ON A WIRE.
3. CAP MATERIAL: GLASS FILLED NYLON 46, UL94 V-0. COLOR SEE PAGE 71.
4. CAP DESIGNED TO ACCOMMODATE WIRE INSULATION.
DIAMETERS 2.10MM TO 2.75MM, 2.75MM TO 3.50MM AND 3.50MM TO 4.25MM.
5. ALL DIMENSIONS ± 0.20 UNLESS STATED.
6. PACKED IN BAGS, QUANTITY 800 PIECES PER BAG.
7. PRODUCT SPECIFICATION REFER TO 201-01-141.
8. FOR ASSEMBLY DETAILS REFER TO APPLICATION NOTES 201-01-142.

SINGLE THRU HOLE IDC CONTACT

12-18 AWG: 9177-600

Accessory Cap - Wire Stop



60-9177-001-6XX-X99 1 WAY WIRE STOP CAP DETAILS

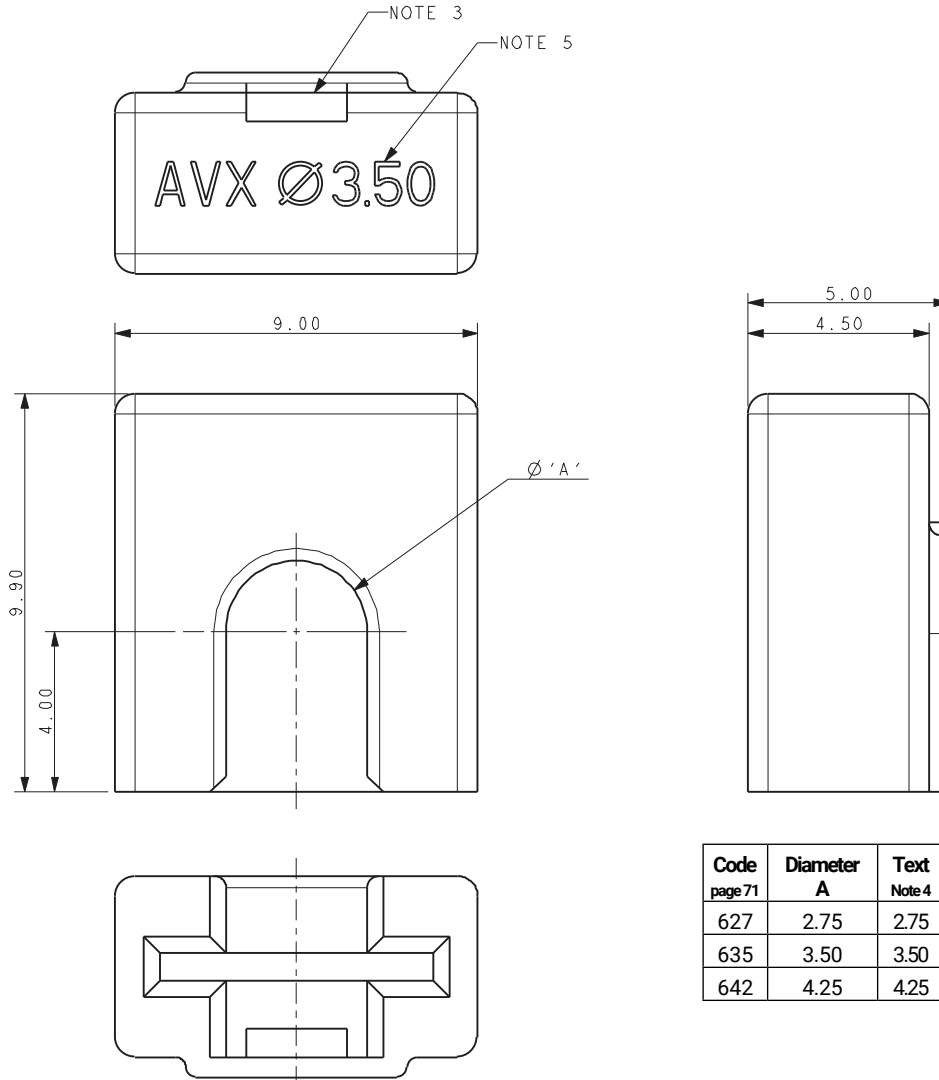

NOTES:

1. CCAP FOR IDC WIRE TO BOARD CONNECTION, 1 WAY WITH WIRE STOP.
2. WIRE STOP FOR USE AT END OF WIRE.
3. SLOT TO CHECK WIRE POSITION BEFORE ASSEMBLY.
4. CAP MATERIAL: GLASS FILLED NYLON 46, UL94 V-0. COLOR SEE PAGE 71.
5. CAP DESIGNED TO ACCOMMODATE WIRE INSULTATION.
DIAMETERS 2.10MM TO 2.75MM, 2.75MM TO 3.50MM AND 3.50MM TO 4.25MM.
6. ALL DIMENSIONS ± 0.20 UNLESS STATED.
7. PACKED IN BAGS, QUANTITY 800 PIECES PER BAG.
8. PRODUCT SPECIFICATION REFER TO 201-01-141.
9. FOR ASSEMBLY DETAILS REFER TO APPLICATION NOTES 201-01-142.