

NIS6111

BERS™ IC (Better Efficiency Rectifier System)

Ultra Efficient, High Speed Diode

The NIS6111 ORing diode is a high speed, high efficiency, hybrid rectifier, designed for low voltage, high current systems, such as those required for today's digital circuits. It couples a high speed integrated circuit with a power MOSFET to create a diode with the same forward drop characteristics as a MOSFET. It offers increased efficiency for switching power supplies as well as in ORing diode applications.

It offers a low on resistance that can be further reduced by the addition of external MOSFETs. It features the highest reverse recovery speed of any device in the industry.

Features

- Low Forward Drop Improves System Efficiency
- Ultra High Speed
- Can be used in High Side and Low Side Configurations
- 24 V Rating
- Allows use of External MOSFETs for Extended Current Handling Capacity
- Pb-Free Package is Available*

Applications

- Redundant Power Supplies for High-Availability Systems
- Static ORing Diodes
- Low Voltage, Isolated Outputs
- Flyback, Forward Converter, Half Bridge Converters

PIN ASSIGNMENT

Pin	Symbol	Function
1	Anode	Power Input Connected to System
2	Bias	Output of Internal Voltage Regulator provides power for internal only. No external components required at this pin.
3	Gate	Gate Driver Output for Internal and External N-Channel MOSFET
4	Cathode	Power Output Connected to System
5	Reg In	Input of Internal Voltage Regulator

*For additional information on our Pb-Free strategy and soldering details, please download the ON Semiconductor Soldering and Mounting Techniques Reference Manual, SOLDERM/D.



ON Semiconductor®

<http://onsemi.com>

MARKING DIAGRAM

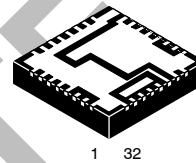

PLL32
CASE 488AC

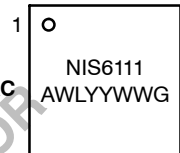

NIS6111 = Specific Device Code
 A = Assembly Location
 WL = Wafer Lot
 YY = Year
 WW = Work Week
 G = Pb-Free Package

PIN CONNECTIONS

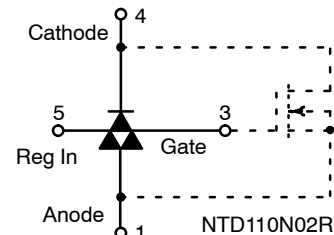
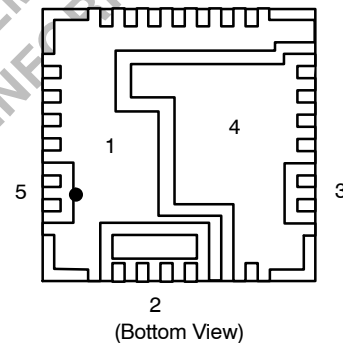

Equivalent Circuit

ORDERING INFORMATION

Device	Package	Shipping†
NIS6111QPT1	PLL32	1500 Tape & Reel
NIS6111QPT1G	PLL32 (Pb-Free)	1500 Tape & Reel

†For information on tape and reel specifications, including part orientation and tape sizes, please refer to our Tape and Reel Packaging Specification Brochure, BRD8011/D.

NIS6111

MAXIMUM RATINGS ($T_J = 25^\circ\text{C}$, unless otherwise noted.)

Rating	Symbol	Value	Unit
Peak Repetitive Reverse Voltage (V_K to V_A)	V_{RRM}	24	V
Peak Regulator Input (Reg In) Voltage	$V_{reg_{max}}$	28	V
Average Rectified Forward Current	I_{FAV}	30	A
Non-repetitive Peak Surge Current	I_{FSM}	90	A
Analog Die Thermal Resistance (Min Copper Area)	$\theta_{A j-a}$	83	$^\circ\text{C/W}$
MOSFET Die Thermal Resistance (Min Copper Area)	$\theta_{M j-a}$	78	$^\circ\text{C/W}$
Analog Die Thermal Resistance (Junction-to-Top of Board)	$\theta_{A j-t}$	4.9	$^\circ\text{C/W}$
MOSFET Die Thermal Resistance (Junction-to-Top of Board)	$\theta_{M j-t}$	0.6	$^\circ\text{C/W}$
Analog Die Thermal Resistance (Junction-to-Bottom of Board) (Note 4)	$\theta_{A j-b}$	30	$^\circ\text{C/W}$
MOSFET Die Thermal Resistance (Junction-to-Bottom of Board) (Note 4)	$\theta_{M j-b}$	7.0	$^\circ\text{C/W}$
Storage Temperature Range	T_{stg}	-55 to 150	$^\circ\text{C}$
Operating Temperature Range	T_J	-40 to 125	$^\circ\text{C}$

Stresses exceeding Maximum Ratings may damage the device. Maximum Ratings are stress ratings only. Functional operation above the Recommended Operating Conditions is not implied. Extended exposure to stresses above the Recommended Operating Conditions may affect device reliability.

OBSOLETE
THIS DEVICE IS OBSOLETE
PLEASE CONTACT YOUR ON SEMICONDUCTOR
REPRESENTATIVE FOR INFORMATION

NIS6111

ELECTRICAL CHARACTERISTICS ($T_J = 25^\circ\text{C}$, Reg In = 8.0 V, unless otherwise noted.)

Characteristic	Symbol	Min	Typ	Max	Unit
----------------	--------	-----	-----	-----	------

SYNCHRONOUS RECTIFIER

ON STATE

Conduction Mode ON Resistance	($I = 10 \text{ Adc}$, $V_{GS} = 5.0 \text{ V}$) ($I = 20 \text{ Adc}$, $V_{GS} = 5.0 \text{ V}$)	R_{ON}	-	3.7 4.7	4.5 -	$\text{m}\Omega$
-------------------------------	--	----------	---	------------	----------	------------------

OFF STATE

Reverse Leakage Current ($V_R = 24 \text{ VDC}$)		I_{DSS}	-	-	10	μA
Reverse Leakage Current ($V_R = 24 \text{ VDC}$, $T_J = 125^\circ\text{C}$)		I_{DSS}	-	-	100	μA

SWITCHING (See Figures 1 and 3) (Note 2)

FET Turn-on Time ($I_{max} = 3.0 \text{ A}$, $I_{rev} = 1.0 \text{ A}$, $V_{rev} = 5.0 \text{ V}$)		t_{sat}	-	45	-	ns
Turnoff Propagation Delay Time ($V_{ds} = V_{offset}$ to $I_D = 0$)		t_{pd}	-	35	-	ns

BODY DIODE

Forward On-Voltage (Notes 1 and 3)	$I = 10 \text{ Adc}$, $V_{GS} = 0 \text{ V}$ $I = 20 \text{ Adc}$, $V_{GS} = 0 \text{ V}$	V_{SD}	-	0.75 0.8	- 1.2	Vdc
------------------------------------	--	----------	---	-------------	----------	-----

POWER SUPPLY ($V_R = 20 \text{ V}$, $T_J = 25^\circ\text{C}$)

Supply Voltage (Pin 2 to Pin 1), Internal Bias Voltage		V_{CC}	4.8	5.0	5.2	V
Cap Charge Time (0.5 V Initial Charge, 5.0 V @ Reg In, to 4.5 V, $C = 0.22 \mu\text{F}$) $T_J = -40^\circ\text{C}$ to 125°C		t_{chg} t_{chg}	2.0 -	3.7 4.7	5.0 -	μs μs
Headroom (for $V_{cap} = 4.7 \text{ V}$)		V_{hd}	1.0	1.27	1.5	V
Minimum Duty Cycle for Operation (Freq = 100 kHz) (Note 5)		d_{min}	-	2.0	-	%
Delay Time ($T_{amb} = 20^\circ\text{C}$)		T_d		51		ns

Reg In Voltage (Pin 5 to Pin 1)

Minimum Voltage Required for Operation ($V_{UVLO} + V_{hd}$)				4.8		V
Minimum Voltage Required for Full Gate Drive ($V_{CC} + V_{hd}$)				6.3		V

CONTROL CIRCUIT

Bias Supply Current ($V_{BIAS} = 5.0 \text{ V}$)		I_{BIAS}	0.8	1.3	1.8	mA
Input Offset Voltage		I_{OS}	-	2.0	5.0	mV
Shutdown Voltage (UVLO)		V_{UVLO}	3.35	3.55	3.65	V
Turn-on Voltage (UVLO)		V_{TO}	3.65	3.81	3.95	V

1. Pulse width $\leq 300 \mu\text{s}$, duty cycle $\leq 2\%$.
2. Pulse width $2.0 \mu\text{s}$, duty cycle $< 5\%$.
3. Switching characteristics are independent of operating junction temperature.
4. Based on 0.062" FR4 board, double-sided 1 oz copper.
5. Minimum time required to recharge internal capacitor.

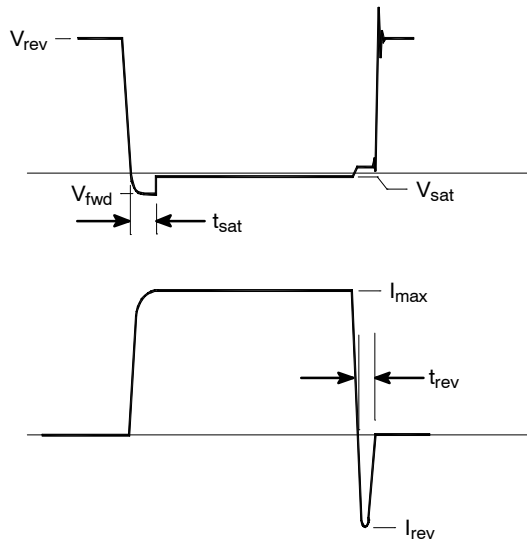

Figure 1. Switching Waveform

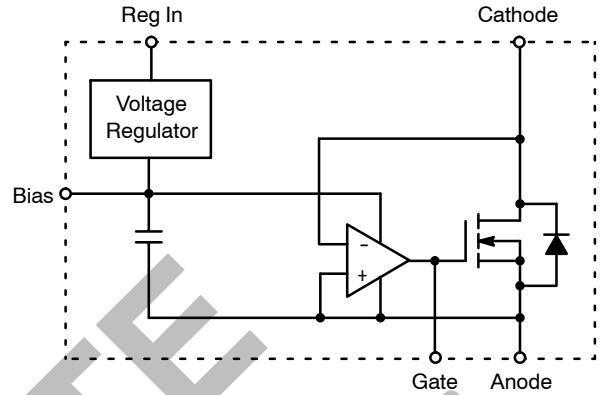

Figure 2. Functional Block Diagram

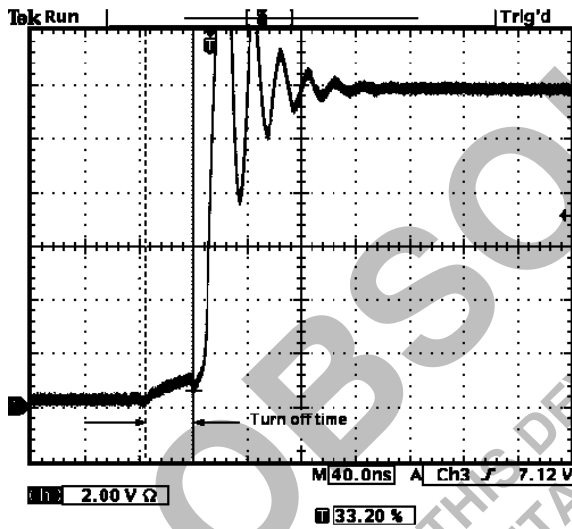

Figure 3. Synchronous Buck Turn Off Delay

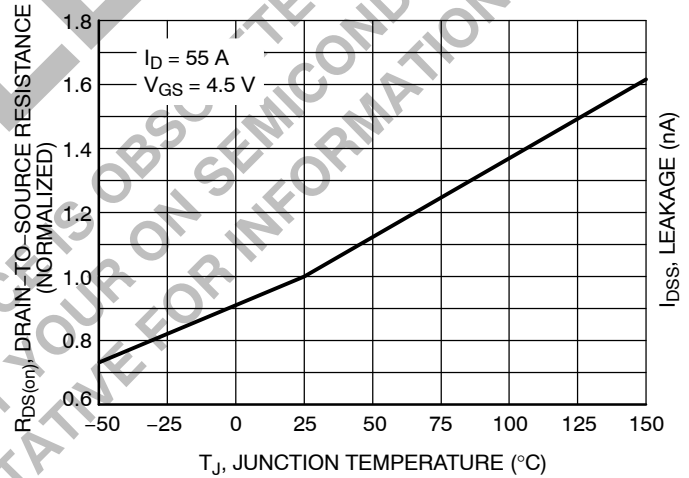

Figure 4. On-Resistance Variation with Temperature

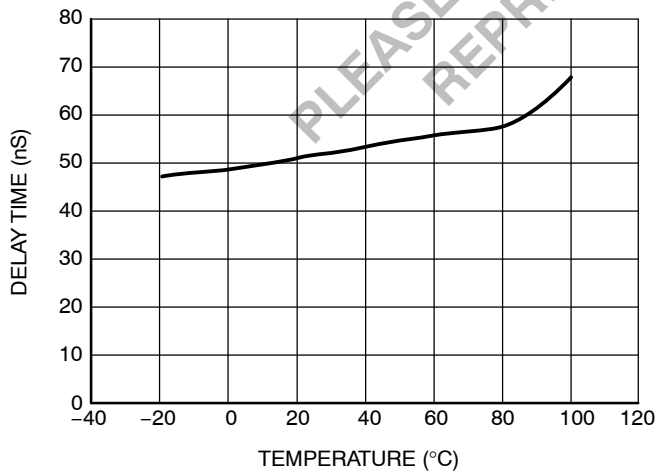

Figure 5. Delay Time versus Temperature

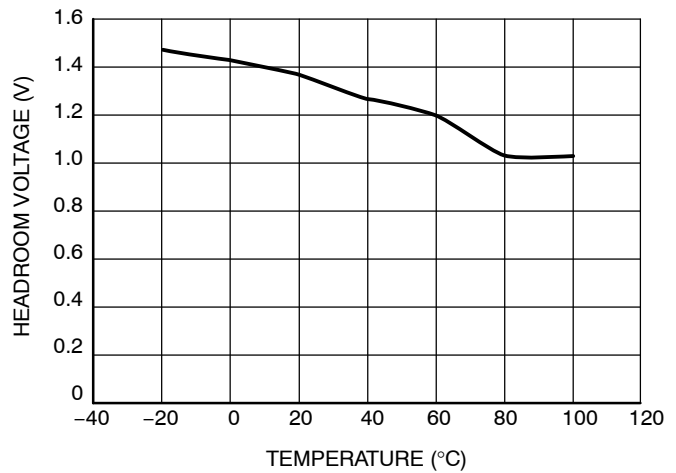

Figure 6. Headroom versus Temperature

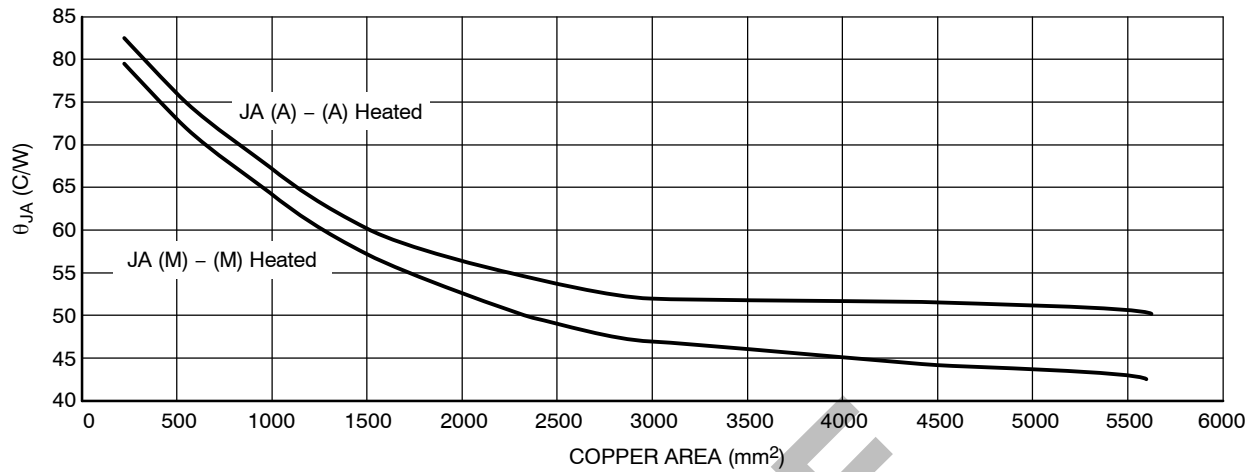

Figure 7. Thermal Resistance vs. Copper Area for MOSFET (M) and Analog Die (A)

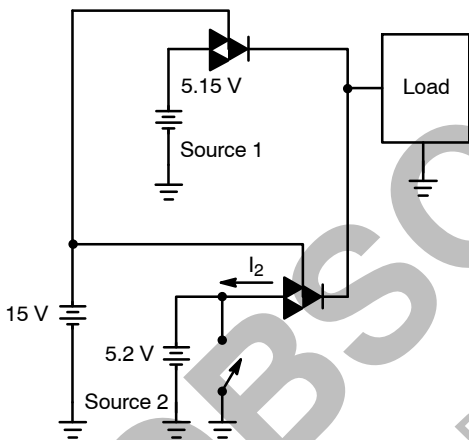

Figure 8. Test Circuit for Short Circuit ORing Test

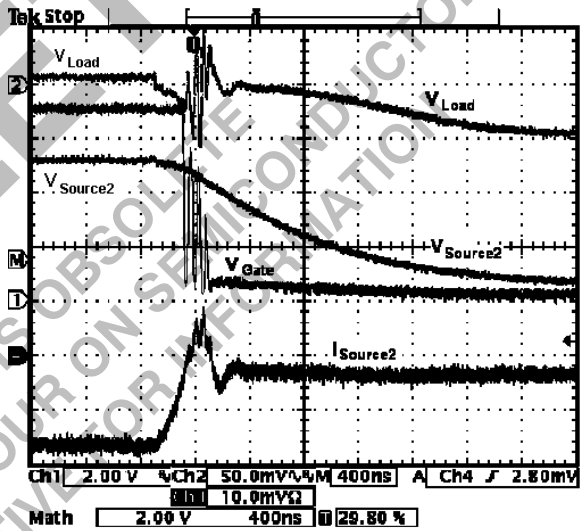

Figure 9. Waveforms from Short Circuit ORing Test

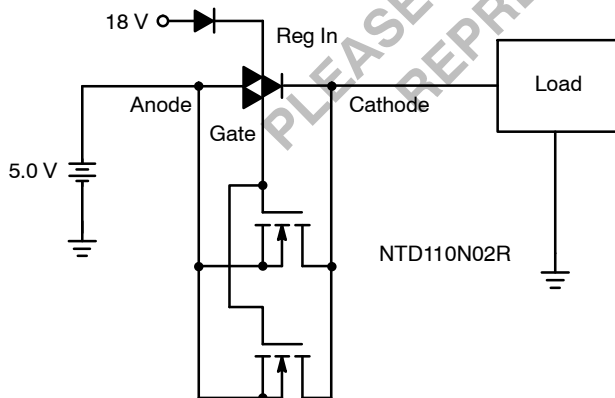

Figure 10. Positive ORing Diode Connection with Additional External FETs

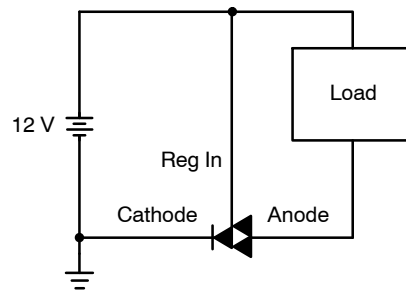

Figure 11. Negative ORing Diode Connection

OPERATING DESCRIPTION

Introduction

The BERS rectifier offers a new concept in rectification for low voltage, high current outputs. This product combines a high speed integrated circuit with a power MOSFET, to create a device with speeds better than an ultrafast silicon rectifier, and a forward drop that is less than that of a Schottky diode.

This device is specifically designed for the low voltage outputs required by today's digital circuits. Current digital products operate on voltages of less than 5.0 V and currents in the tens to hundreds of amperes. BERS can greatly increase the efficiency of low voltage, high current converters, by reducing the rectifier drop to several hundred millivolts.

This device consists of four major circuits as well as a capacitor. BERS contains a power supply to regulate the voltage on the bias supply cap, a high speed comparator to sense the conduction state of the device, a high speed driver, a power FET and a capacitor.

Bias Supply

The internal bias supply is a high current, switching regulator. It will maintain a regulated voltage on the internal capacitor as long as sufficient voltage is available at the Reg In pin. When this pin is high, a current limited switch allows current to charge the capacitor. When the

maximum charge voltage is reached, the switch is turned off. If there is not sufficient reverse voltage to maintain a 5.0 V charge on the capacitor, the bias supply will charge it to within 1.0 V of the reverse voltage.

The Regulator Input pin can be connected to the cathode and will recharge the internal capacitor when the BERS is reversed biased. This input requires a minimum voltage of 4.7 V to operate. In some cases this amount of reverse voltage may not be available. When this is the case, the Reg In pin can be connected to a higher voltage source. It is not necessary that this source be synchronous with the cathode voltage.

The Reg In voltage should not be allowed to go more negative than the anode of the device. If this scenario can occur, a small switching diode should be placed in series with the Reg In pin.

Comparator/Driver

The polarity comparator is a medium gain, ultra high speed design. It is integrated with the driver circuit, to optimize the switching speed of the device. The comparator input has a low offset voltage which biases the inverting input several millivolts above ground. This is to assure that at zero (or very low) current levels, the device is off.

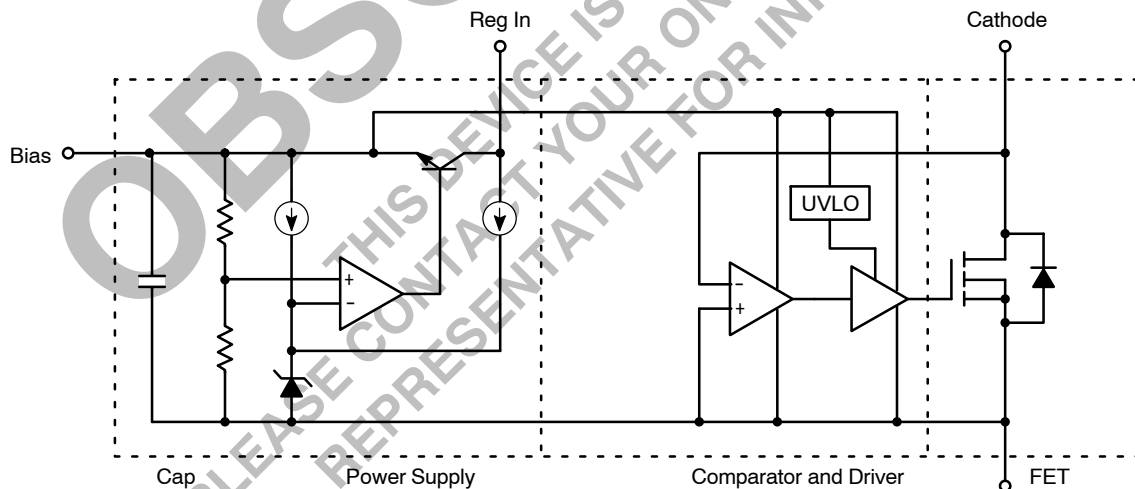
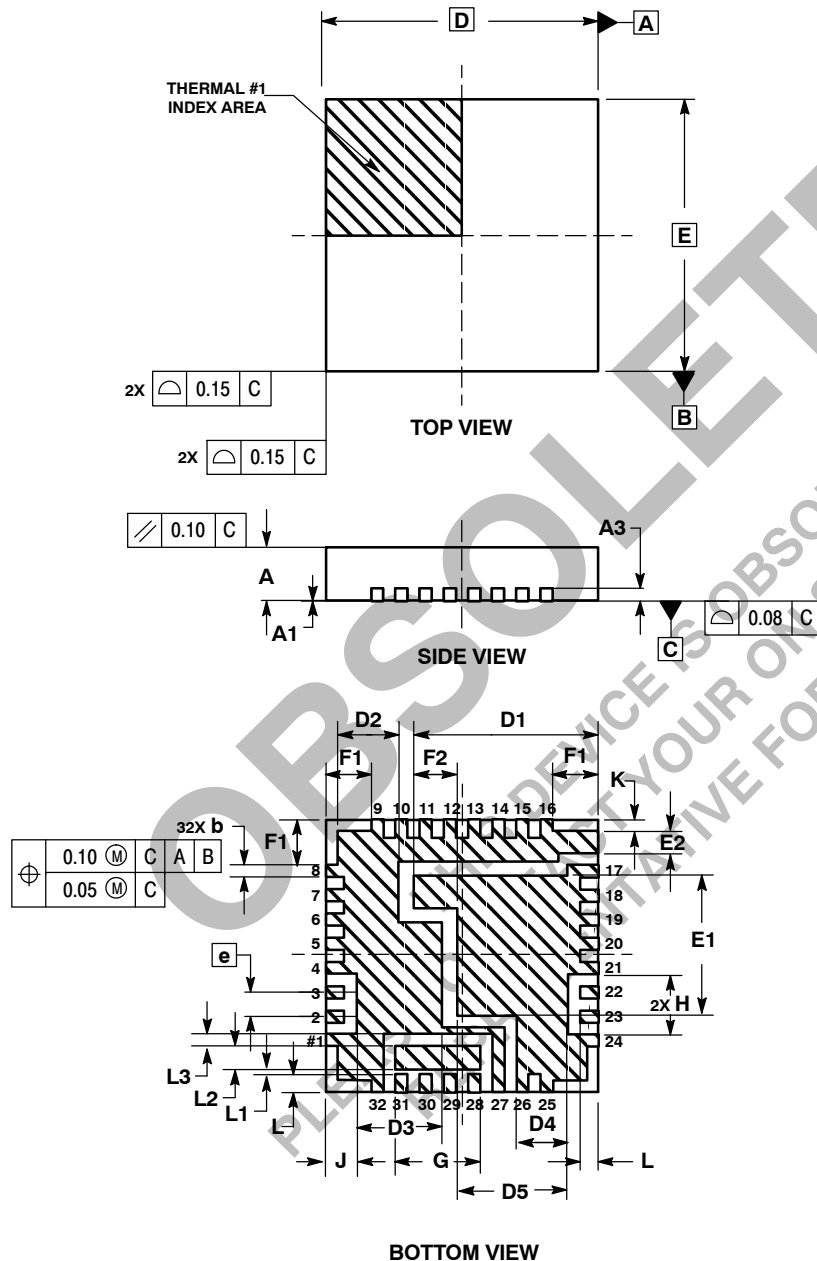

Figure 12. Detailed Block Diagram

PACKAGE DIMENSIONS

PLL32
CASE 488AC-01
ISSUE A



- NOTES:
1. DIMENSIONING AND TOLERANCING PER ASME Y14.5M, 1994.
 2. CONTROLLING DIMENSION: MILLIMETERS.
 3. DIMENSION b APPLIES TO METALLIZED TERMINAL AND IS MEASURED BETWEEN 0.25 MM AND 40 MM FROM TERMINAL TIP
 4. UNILATERAL COPLANARITY ZONE APPLIES TO THE EXPOSED HEAT SINK SLUG AS WELL AS THEIR TERMINALS.

DIM	MILLIMETERS		
	MIN	NOM	MAX
A	1.750	1.850	1.950
A1	0.000	----	0.050
A3	0.254 REF		
b	0.350	0.400	0.450
D	9.000 BSC		
D1	5.987	6.087	6.187
D2	1.924	2.024	2.124
D3	2.713	2.813	2.913
D4	1.584	1.684	1.784
D5	3.547	3.647	3.747
E	9.000 BSC		
E1	4.472	4.572	4.672
E2	0.638	0.738	0.838
e	0.800 BSC		
F1	1.500 REF		
F2	1.324	1.424	1.524
G	2.700	2.800	2.900
H	2.000 REF		
J	1.016 BSC		
K	0.381 REF		
L	0.500	0.600	0.700
L1	0.062	0.162	0.262
L2	0.760	0.770	0.870
L3	0.281	0.381	0.481

OBSOLETE
THIS DEVICE IS OBSOLETE
PLEASE CONTACT YOUR ON SEMICONDUCTOR
REPRESENTATIVE FOR INFORMATION

BERS is a trademark of Semiconductor Components Industries, LLC (SCILLC).

The product described herein (NIS6111), may be covered by U.S. patents including 6,271,712. There may be other patents pending.

ON Semiconductor and **ON** are registered trademarks of Semiconductor Components Industries, LLC (SCILLC). SCILLC reserves the right to make changes without further notice to any products herein. SCILLC makes no warranty, representation or guarantee regarding the suitability of its products for any particular purpose, nor does SCILLC assume any liability arising out of the application or use of any product or circuit, and specifically disclaims any and all liability, including without limitation special, consequential or incidental damages. "Typical" parameters which may be provided in SCILLC data sheets and/or specifications can and do vary in different applications and actual performance may vary over time. All operating parameters, including "Typicals" must be validated for each customer application by customer's technical experts. SCILLC does not convey any license under its patent rights nor the rights of others. SCILLC products are not designed, intended, or authorized for use as components in systems intended for surgical implant into the body, or other applications intended to support or sustain life, or for any other application in which the failure of the SCILLC product could create a situation where personal injury or death may occur. Should Buyer purchase or use SCILLC products for any such unintended or unauthorized application, Buyer shall indemnify and hold SCILLC and its officers, employees, subsidiaries, affiliates, and distributors harmless against all claims, costs, damages, and expenses, and reasonable attorney fees arising out of, directly or indirectly, any claim of personal injury or death associated with such unintended or unauthorized use, even if such claim alleges that SCILLC was negligent regarding the design or manufacture of the part. SCILLC is an Equal Opportunity/Affirmative Action Employer. This literature is subject to all applicable copyright laws and is not for resale in any manner.

PUBLICATION ORDERING INFORMATION

LITERATURE FULFILLMENT:

Literature Distribution Center for ON Semiconductor
P.O. Box 5163, Denver, Colorado 80217 USA
Phone: 303-675-2175 or 800-344-3860 Toll Free USA/Canada
Fax: 303-675-2176 or 800-344-3867 Toll Free USA/Canada
Email: orderlit@onsemi.com

N. American Technical Support: 800-282-9855 Toll Free
USA/Canada
Europe, Middle East and Africa Technical Support:
Phone: 421 33 790 2910
Japan Customer Focus Center
Phone: 81-3-5773-3850

ON Semiconductor Website: www.onsemi.com

Order Literature: <http://www.onsemi.com/orderlit>

For additional information, please contact your local Sales Representative