

LOC		DIST		REVISIONS				
AD	00	REV	BY	DESCRIPTION	DATE	DN	APVD	
G		REVIS	PER	ECO-14-000066	21JUL2014	NK	MM	

- 1 TRUE POSITION TOLERANCE OF THE POST TIPS APPLIES WHEN THE HEADERS ARE HELD FLAT AGAINST THE PRINTED CIRCUIT BOARD
- 2 THE NOTED DIMENSIONS APPLY AT THE INTERSECTION OF THE POST AND THE HOUSING
- 3 POINT OF MEASUREMENT FOR PLATING THICKNESS
- 4 RETENTION FEATURE ON SOLDEXTAILS LOCATED AT MANUFACTURER'S OPTION.
- 5 $\varnothing .020 \text{ @}$ FOR KINKED TAILS
- 6 OBSOLETE PARTS: OBSOLETE CIS STREAMLINING PER D.RENAUD/D.SINISI

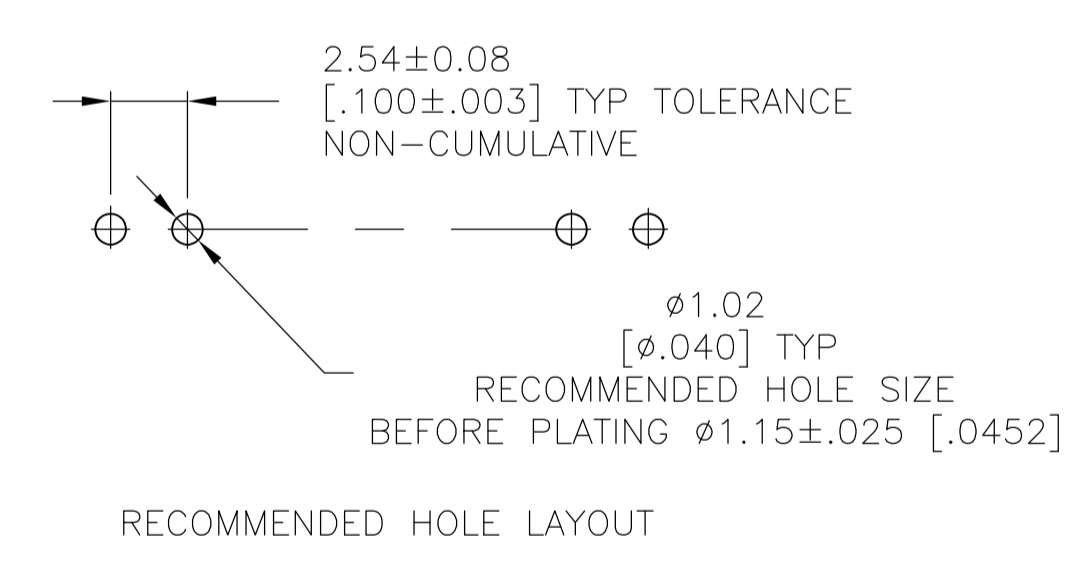
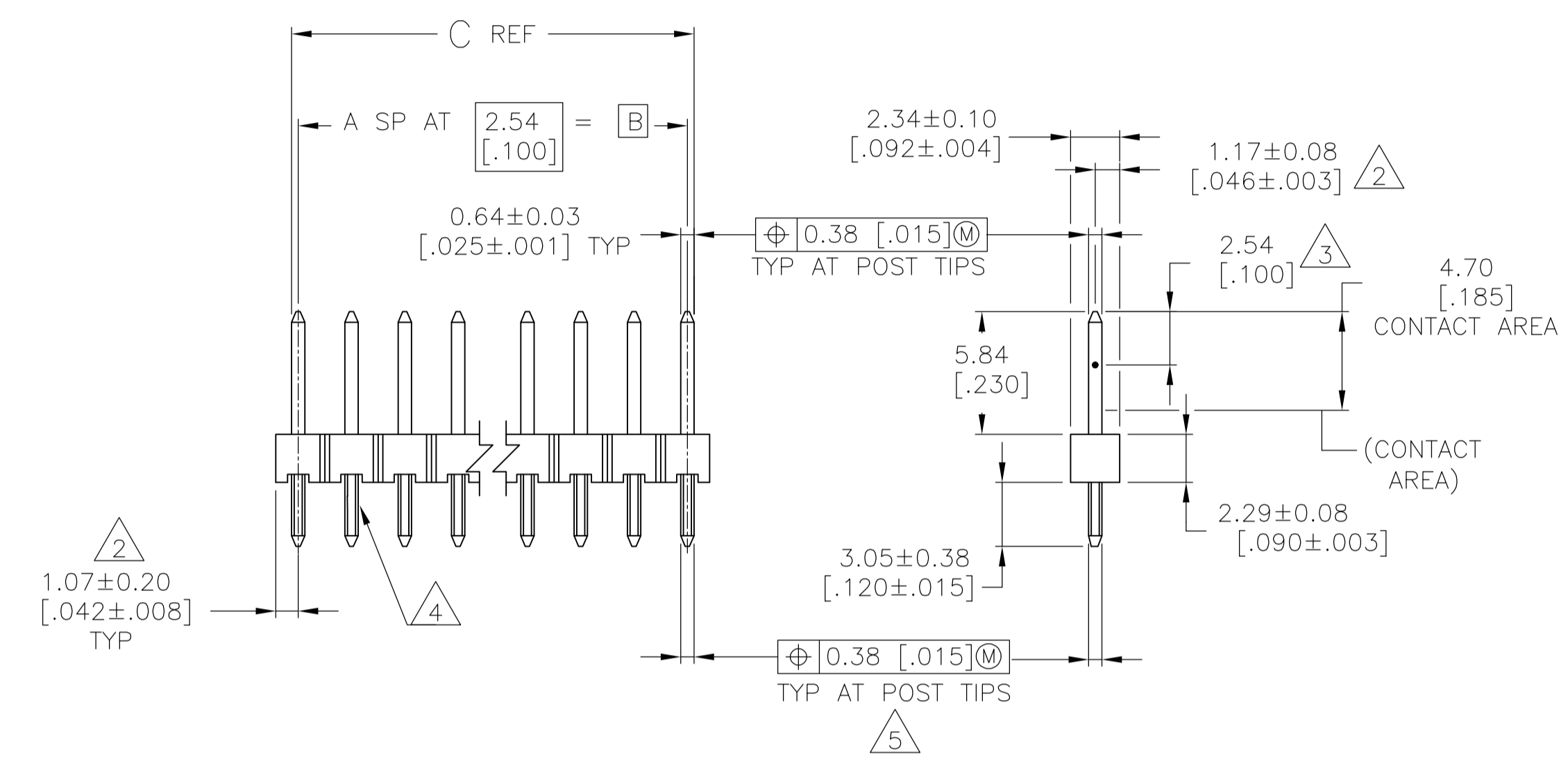

OBSOLETE

101.19	[3.984]	99.06	[3.900]	39	40	3-146127-8
98.65	[3.884]	96.52	[3.800]	38	39	3-146127-7
96.11	[3.784]	93.98	[3.700]	37	38	3-146127-6
93.57	[3.684]	91.44	[3.600]	36	37	3-146127-5
91.03	[3.584]	88.90	[3.500]	35	36	3-146127-4
88.49	[3.484]	86.36	[3.400]	34	35	3-146127-3
85.95	[3.384]	83.82	[3.300]	33	34	3-146127-2
83.41	[3.284]	81.28	[3.200]	32	33	3-146127-1
80.87	[3.184]	78.74	[3.100]	31	32	3-146127-0
78.33	[3.084]	76.20	[3.000]	30	31	2-146127-9
75.79	[2.984]	73.66	[2.900]	29	30	2-146127-8
73.25	[2.884]	71.12	[2.800]	28	29	2-146127-7
70.71	[2.784]	68.58	[2.700]	27	28	2-146127-6
68.17	[2.684]	66.04	[2.600]	26	27	2-146127-5
65.63	[2.584]	63.50	[2.500]	25	26	2-146127-4
63.09	[2.484]	60.96	[2.400]	24	25	2-146127-3
60.55	[2.384]	58.42	[2.300]	23	24	2-146127-2
58.01	[2.284]	55.88	[2.200]	22	23	2-146127-1
55.47	[2.184]	53.34	[2.100]	21	22	2-146127-0
52.93	[2.084]	50.80	[2.000]	20	21	1-146127-9
50.39	[1.984]	48.26	[1.900]	19	20	1-146127-8
47.85	[1.884]	45.72	[1.800]	18	19	1-146127-7
45.31	[1.784]	43.18	[1.700]	17	18	1-146127-6
42.77	[1.684]	40.64	[1.600]	16	17	1-146127-5
40.23	[1.584]	38.10	[1.500]	15	16	1-146127-4
37.69	[1.484]	35.56	[1.400]	14	15	1-146127-3
35.15	[1.384]	33.02	[1.300]	13	14	1-146127-2
32.61	[1.284]	30.48	[1.200]	12	13	1-146127-1
30.07	[1.184]	27.94	[1.100]	11	12	1-146127-0
27.53	[1.084]	25.40	[1.000]	10	11	146127-9
24.99	[0.984]	22.86	[0.900]	9	10	146127-8
22.45	[0.884]	2.32	[0.800]	8	9	146127-7
19.91	[0.784]	17.78	[0.700]	7	8	146127-6
17.37	[0.684]	15.24	[0.600]	6	7	146127-5
14.83	[0.584]	12.70	[0.500]	5	6	146127-4
12.29	[0.484]	1.16	[0.400]	4	5	146127-3
9.75	[0.384]	7.62	[0.300]	3	4	146127-2
7.21	[0.284]	5.08	[0.200]	2	3	146127-1

THIS DRAWING IS A CONTROLLED DOCUMENT.

DIMENSIONS: mm [INCHES]
 TOLERANCES UNLESS OTHERWISE SPECIFIED:
 0. PLC ± -
 1. PLC ± ±
 2. PLC ± ± 0.13[0.005]
 3. PLC ± ± -
 4. PLC ± ± -
 ANGLES ± ± -

MATERIAL: HOUSING: FLAME RETARDANT THERMOPLASTIC COLOUR: BLACK CONTACT: COPPER ALLOY
 FINISH: POSTS: 100% GOLD IN CONTACT AREA, 50%Au-50%Ni WITH THE LEAD ON SOLDER TAIL ALL OVER 100% NiPd.

DWG: J. KNAUB 17JUN94
 CHK: G. DUBNICZKI 17JUN94
 APVD: G. DUBNICZKI 17JUN94
 NAME: HEADER ASSY, MOD II, BREAKAWAY, SINGLE ROW, .100 C, VERT. .025 SQ POSTS, WITH RETENTION FEATURE
 APPLICATION SPEC: -
 SIZE: A1
 WEIGHT: -
 SCALE: 4:1
 SHEET: 1 OF 1
 REV: G

CUSTOMER DRAWING
 NO OF POSN: 40
 ASSEMBLY PART NUMBER: 3-146127-8