

DESIGNED AND DIMENSIONED IN MILLIMETERS [INCHES]
ALL DIMENSIONS REFERENCE EXCEPT AS SHOWN

DO NOT SCALE FROM THIS PRINT

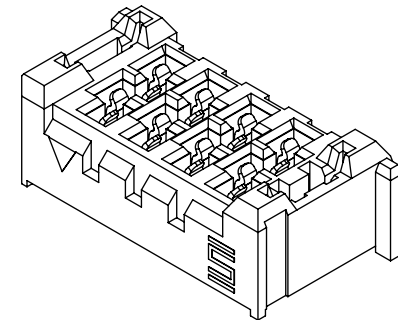
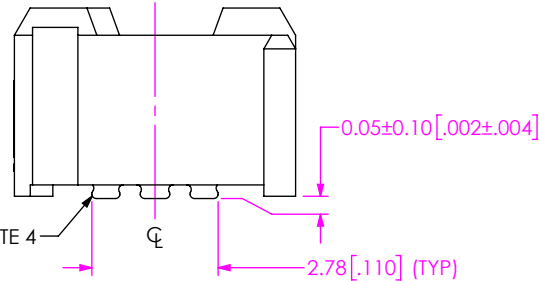
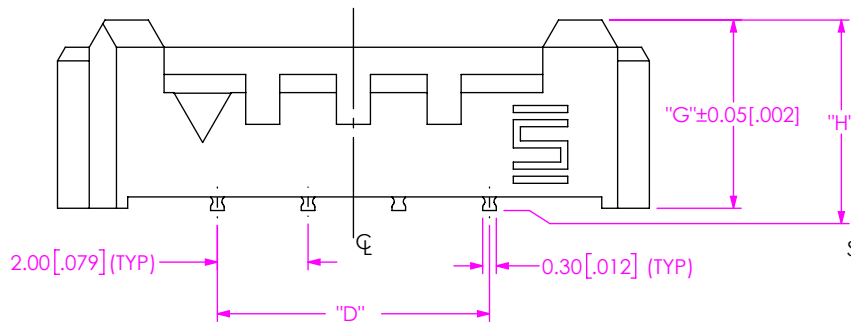
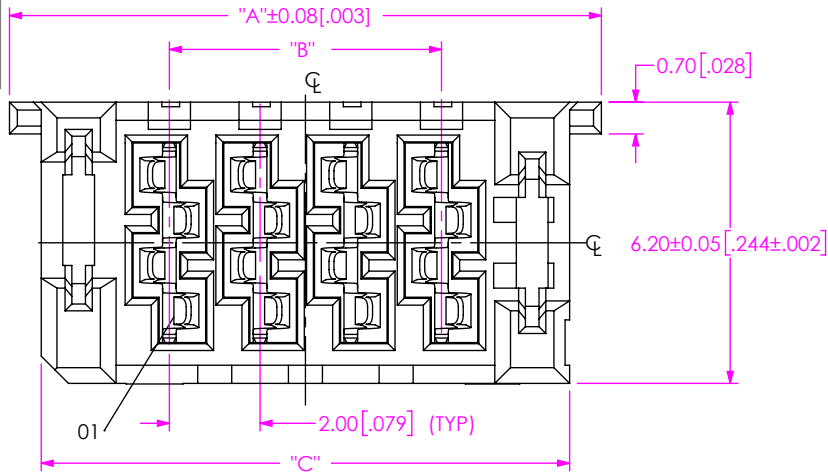

UMPS-XX-XX.X-XX-V-X-X-XR

NO. OF POSITIONS
-02, -03, -04, -05,
-06, -07, -08, -09, -10

TAPE & REEL
-TR: TAPE & REEL
-FR: FULL REEL QTY TAPE & REEL

LEAD STYLE
-03.5: 3.5 mm
-05.5: 5.5 mm
-07.5: 7.5mm

WELD TAB OPTIONS
(LEAVE BLANK FOR NO WELD TAB)
**-W: WELD TAB THROUGH HOLE

TAIL
** -S: SURFACE MOUNT
*-1: THROUGH HOLE FOR 1.57 [.062]PCB
*-2: THROUGH HOLE FOR 2.36 [.093]PCB

PLATING
-T: MATTE TIN
-G: 10µ" SELECTIVE GOLD IN CONTACT AREA, 3µ" GOLD ON TAIL, MATTE TIN ON THE WELD TAB
-L: 10µ" SELECTIVE GOLD IN CONTACT AREA, MATTE TIN ON TAIL, MATTE TIN ON THE WELD TAB
-S: 30µ" SELECTIVE GOLD IN CONTACT AREA, MATTE TIN ON TAIL, MATTE TIN ON THE WELD TAB
-SL: 30µ" SELECTIVE GOLD ON CONTACT AREA, TIN-LEAD ON TAIL, TIN-LEAD ON THE WELD TAB

ORIENTATION
**-V: VERTICAL

(* = NOT TOOLED)
(** = SEE NOTE 7)

FIG 1
UMPS-04-03.5-XX-V-S SHOWN

UMPT LEAD STYLE	UMPS LEAD STYLE		
	-03.5	-05.5	-07.5
-01.5	5.00 [0.197]	7.00 [0.276]	9.00 [0.354]
-02.5	6.00 [0.236]	8.00 [0.315]	10.00 [0.394]
-06.5	10.00 [0.394]	12.00 [0.472]	14.00 [0.551]
-07.5	11.00 [0.433]	13.00 [0.512]	15.00 [0.591]
-12.5	16.00 [0.630]	18.00 [0.709]	20.00 [0.787]

LEAD STYLE	"G"	"H"	"J"
-03.5	4.15 [0.163]	4.20 [0.165]	3.68 [0.145]
-05.5	6.15 [0.242]	6.20 [0.244]	5.68 [0.224]
-07.5	8.15 [0.321]	8.20 [0.323]	7.68 [0.302]

No OF POSITION	"A"	"B"	"C"	"D"	"E"
-02	9.05 [.356]	2.00 [.079]	7.65 [.301]	2.00 [.079]	6.00 [.236]
-03	11.05 [.435]	4.00 [.157]	9.65 [.380]	4.00 [.157]	8.00 [.315]
-04	13.05 [.514]	6.00 [.236]	11.65 [.459]	6.00 [.236]	10.00 [.394]
-05	15.05 [.593]	8.00 [.315]	13.65 [.537]	8.00 [.315]	12.00 [.472]
-06	17.05 [.671]	10.00 [.394]	15.65 [.616]	10.00 [.394]	14.00 [.551]
-07	19.05 [.750]	12.00 [.472]	17.65 [.695]	12.00 [.472]	16.00 [.630]
-08	21.05 [.829]	14.00 [.551]	19.65 [.774]	14.00 [.551]	18.00 [.709]
-09	23.05 [.907]	16.00 [.630]	21.65 [.852]	16.00 [.630]	20.00 [.787]
-10	25.05 [.986]	18.00 [.709]	23.65 [.931]	18.00 [.709]	22.00 [.866]

- NOTES:
1. NOTE DELETED.
2. NOTE DELETED.
3. NOTE DELETED.
4. HOLES IN THE SURFACE MOUNT TAILS MAY OR MAY NOT BE PRESENT, AT SAMTEC DISCRETION.
5. ORDERS WILL BE PACKAGED ACCORDING TO THE SAMTEC PACKAGING EFFICIENCY STANDARDS (SPES) FOUND ON WWW.SAMTEC.COM.
6. ATTACH LABEL -4X2 TO EACH REEL.
7. PREVIOUS OPTIONS -VT, -SM, &-WT AVAILABLE FOR EXISTING CUSTOMERS ONLY.
8. K DOT SUPPLIED AS STANDARD, -K PART NUMBER OPTION AVAILABLE TO EXISTING CUSTOMERS ONLY

PROPRIETARY NOTE
THIS DOCUMENT CONTAINS CONFIDENTIAL AND PROPRIETARY INFORMATION AND ALL DESIGN, MANUFACTURING, REPRODUCTION, USE, PATENT RIGHTS AND SALES RIGHTS ARE EXPRESSLY RESERVED BY SAMTEC, INC. THIS DOCUMENT SHALL NOT BE DISCLOSED, IN WHOLE OR PART, TO ANY UNAUTHORIZED PERSON OR ENTITY NOR REPRODUCED, TRANSFERRED OR INCORPORATED IN ANY OTHER PROJECT IN ANY MANNER WITHOUT THE EXPRESS WRITTEN CONSENT OF SAMTEC, INC.

DO NOT SCALE DRAWING
SHEET SCALE: 6:1

MATERIAL:
INSULATOR: LCP
CONTACT: COPPER ALLOY
WELD TAB: COPPER ALLOY



520 PARK EAST BLVD, NEW ALBANY, IN 47150
PHONE: 812-944-6733 FAX: 812-948-5047
e-Mail info@SAMTEC.com code 55322

DESCRIPTION:
ULTRA MICRO POWER SOCKET

DWG. NO.
UMPS-XX-XX.X-XX-V-X-X-XR

BY: JOE Z 03/22/2017 SHEET 1 OF 2

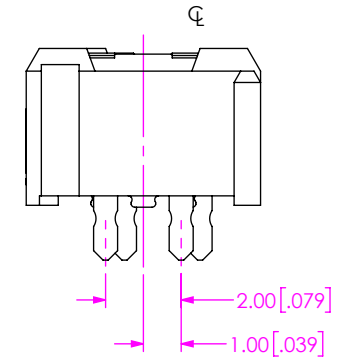
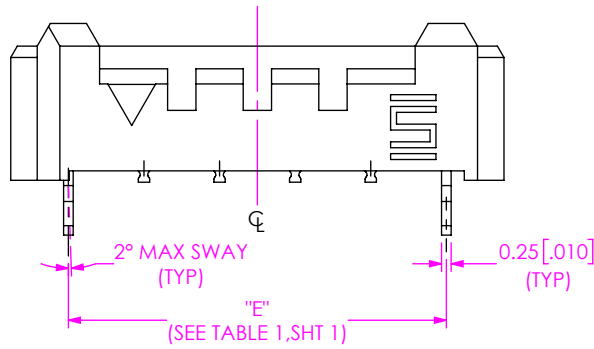
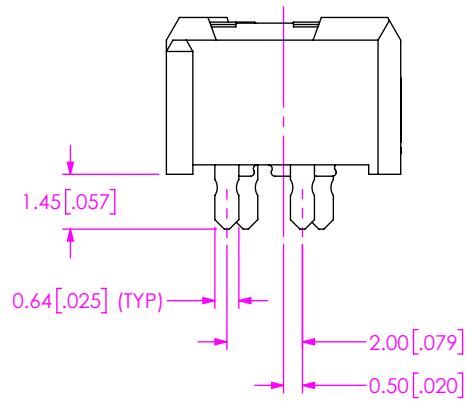
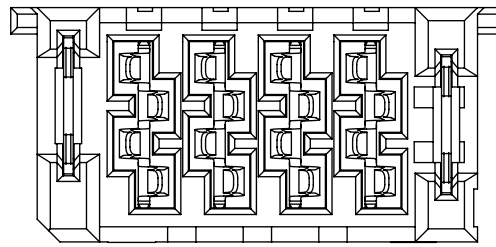

FIG 2
UMPS-04-03.5-XX-V-S-W SHOWN
(DIFFERENT AS SHOWN, OTHERWISE SAME AS FIG 1)

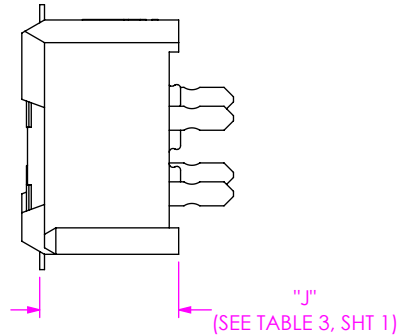
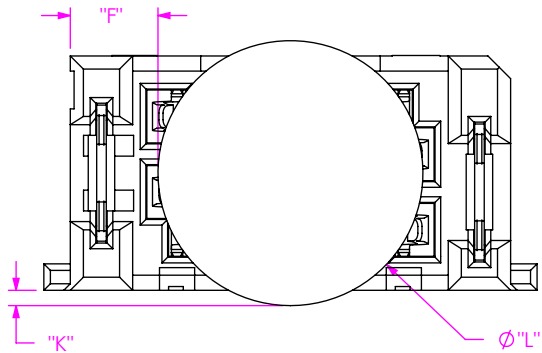

FIG 3
UMPS-04-03.5-XX-V-S-W SHOWN
(DIFFERENT AS SHOWN, OTHERWISE SAME AS FIG 2)

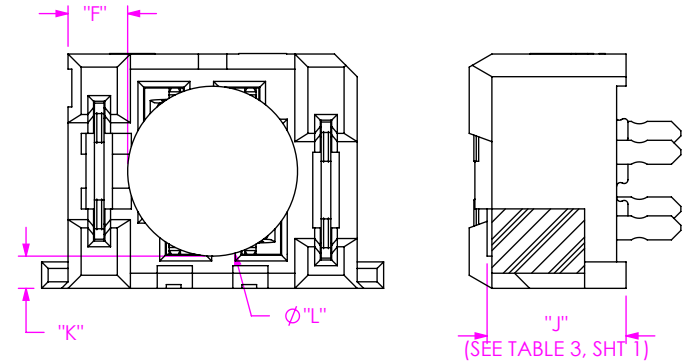

FIG 4
UMPS-02-03.5-XX-V-S-W SHOWN
(DIFFERENT AS SHOWN, OTHERWISE SAME AS FIG 2)

TABLE 4

No OF POSITION	"F"	"K"	"L"
-02	1.58 [.062]	0.85 [.034]	4.50 [.177]
-03	1.57 [.062]	0.15 [.006]	6.50 [.256]
-04	2.32 [.091]	0.41 [.016]	7.01 [.276]
-05	3.32 [.131]	0.41 [.016]	7.01 [.276]
-06	4.32 [.170]	0.41 [.016]	7.01 [.276]
-07	5.32 [.209]	0.41 [.016]	7.01 [.276]
-08	6.32 [.249]	0.41 [.016]	7.01 [.276]
-09	7.32 [.288]	0.41 [.016]	7.01 [.276]
-10	8.32 [.328]	0.41 [.016]	7.01 [.276]

PROPRIETARY NOTE
THIS DOCUMENT CONTAINS CONFIDENTIAL AND PROPRIETARY INFORMATION AND ALL DESIGN, MANUFACTURING, REPRODUCTION, USE, PATENT RIGHTS AND SALES RIGHTS ARE EXPRESSLY RESERVED BY SAMTEC, INC. THIS DOCUMENT SHALL NOT BE DISCLOSED, IN WHOLE OR PART, TO ANY UNAUTHORIZED PERSON OR ENTITY NOR REPRODUCED, TRANSFERRED OR INCORPORATED IN ANY OTHER PROJECT IN ANY MANNER WITHOUT THE EXPRESS WRITTEN CONSENT OF SAMTEC, INC.



520 PARK EAST BLVD, NEW ALBANY, IN 47150
PHONE: 812-944-6733 FAX: 812-948-5047
e-Mail info@SAMTEC.com code 55322

DO NOT SCALE DRAWING

SHEET SCALE: 2:1

DESCRIPTION:
ULTRA MICRO POWER SOCKET

DWG. NO.
UMPS-XX-XX.X-XX-V-X-X-XR

BY: JOE Z 03/22/2017 SHEET 2 OF 2