

© - TE Connectivity. All Rights Reserved.

REVISIONS				
P	LTR	DESCRIPTION	DATE	APVD
	N6	REVISED PER ECN-22-156403	03JUN2022	RK CSD

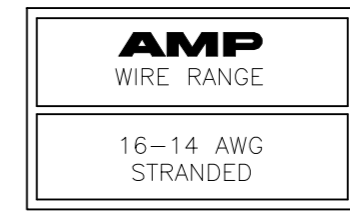
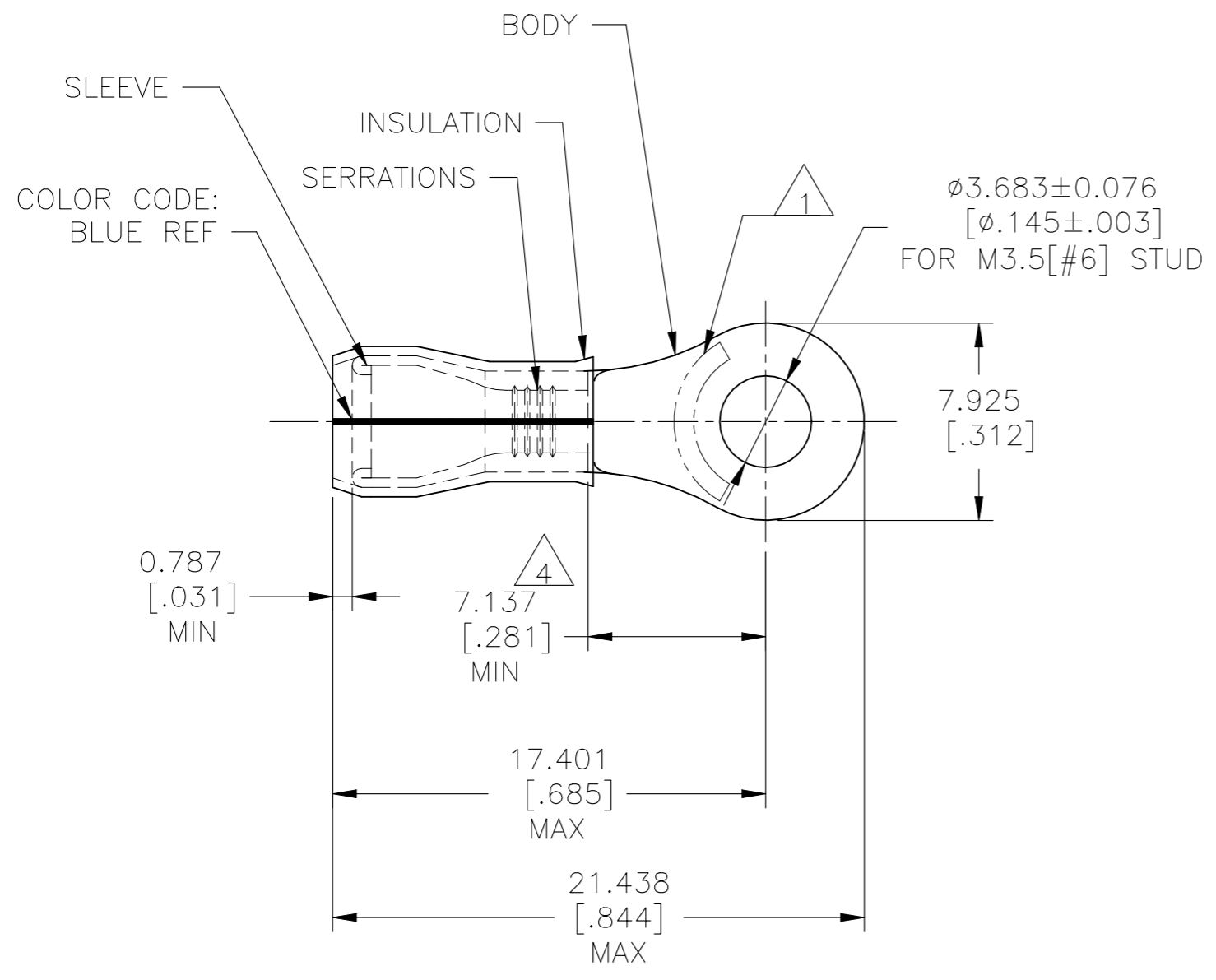

- 1 STAMP AMP 16-14* APPROX AS SHOWN.
- 2 WIRE INSULATION : $\phi 2.667-3.810$ [$\phi .105-.150$]
- 3 BODY MATERIAL THK: 0.787 ± 0.051 [$.031 \pm .002$]
- 4 APPLIES FROM EDGE OF METAL WIRE BARREL TO CENTER OF STUD HOLE.
- 5 MEETS M7928/4-107, CLASS 1
MEETS M7928/13-107, CLASS 1
- 6 NOTE DELETED
- 7 MATERIAL:
BODY & SLEEVE: COPPER PER ASTM B152
INSULATION: PVF2
- 8 FINISH:
BODY & SLEEVE: TIN/LEAD (93-7) PLATE PER
ASTM B545 (3% MIN LEAD CONTENT)
INSULATION: COLOR-NATURAL.

5000	ON TAPE, REEL	53416-2
1000	LOOSE PIECE	53416-1
QTY	PACKAGE TYPE	PART NO

AMP INCORPORATED CUSTOMER SERVICE SYSTEMS		MAX RECOMMENDED OPERATING TEMPERATURE: 150°C [302°F] MAX	THIS DRAWING IS A CONTROLLED DOCUMENT.		DWN JR RUTH 25OCT07	TE Connectivity					
FOR ADDITIONAL PRODUCT INFORMATION OR COPIES OF DRAWINGS AND TECHNICAL DOCUMENTS	PRODUCT INFORMATION CENTER 1-800-522-6752	VOLTAGE RATING: N/A	DIMENSIONS: mm [INCHES]	TOLERANCES UNLESS OTHERWISE SPECIFIED:	CHK T MICHELUTTI 25OCT07				NAME TERMINAL, RING TONGUE, PVF2, P.I.D.G. WIRE SIZE: 16-14 AWG		
FOR APPLICATION TOOLING INFORMATION	TOOLING ASSISTANCE CENTER 1-800-722-1111	CIRCULAR MIL AREA: 1.04-2.62mm ² [2,050-5,180] STRANDED		0 PLC ± - 1 PLC ± - 2 PLC ± - 3 PLC ± 0.127[.005] 4 PLC ± - ANGLES ± -	APVD T MICHELUTTI 25OCT07	APPLICATION SPEC 114-2157	SIZE A3	CAGE CODE 00779	DRAWING NO C-53416	RESTRICTED TO -	
FOR ORDER ENTRY	1-800-526-5142	THIS DRAWING IS A CONTROLLED DOCUMENT FOR AMP INCORPORATED. IT IS SUBJECT TO CHANGE AND THE CONTROLLING ENGINEERING ORGANIZATION SHOULD BE CONTACTED FOR THE LATEST REVISION.	MATERIAL 7	FINISH 8	PRODUCT SPEC -	WEIGHT -	CUSTOMER DRAWING		SCALE 4:1	SHEET 1 OF 1	REV N6