

HC872



When precision matters.®

HC872 Dual Band Helical Antenna + L-band

Frequency Coverage: L1/L2/G1/G2/E1/B1 + L-band

Overview

The lightweight HC872 helical antenna, which covers the GPS L1/L2, GLONASS G1/G2, Galileo E1, and BeiDou B1 frequency bands, as well as L-band correction services coverage, is designed and crafted for precision positioning.

Weighing 37 g, the lightweight HC872 features a precision-tuned helix element that provides excellent axial ratios and operates without the requirement of a ground plane, making it ideal for a wide variety of applications including Unmanned Aerial Vehicles (UAVs).

The HC872 features an industry-leading low current, Low Noise Amplifier (LNA) that includes an integrated low-loss pre-filter to protect against harmonic interference from high amplitude interfering signals, such as 700 MHz band LTE and other near in-band cellular signals.

The HC872 is protected by a robust, military-grade plastic enclosure with an integrated SMA connector for screw-on mounting that securely seals the unit with an O-ring, complying with IP67 standards. The enclosure also provides two threaded holes in the base for secure attachment of the unit.



Applications

- Autonomous, Unmanned Aerial Vehicles
- Precision GPS positioning
- Dual Frequency RTK receivers
- Mission-critical GPS timing
- Military & security
- Network timing and synchronization

Features

- Very low noise preamp, 2 dB
- Axial ratio: ≤ 0.5 dB max.
- LNA gain 35 dB typ. or 28 dB typ.
- Low current: 18 mA typ. or 12 mA typ.
- ESD circuit protection: 15 kV
- Invariant performance from: +2.2 to 16 VDC

Benefits

- Extremely lightweight (37 g)
- Ideal for L1/L2 RTK surveying systems
- Great multipath rejection
- Increased system accuracy
- Excellent signal to noise ratio
- IP67, REACH, and RoHS compliant

About Tallysman: With global headquarters and manufacturing in Ottawa, Canada, Tallysman is a leading manufacturer of high-precision antennas and components for Global Navigation Satellite System (GNSS) applications. Tallysman's mission is to support the needs of a new generation of positioning systems by delivering unprecedented antenna precision at competitive prices. Learn more at www.tallysman.com

Contact us:
info@tallysman.com
T: +1 613 591-3131

HC872 Dual Band Helical Antenna + L-band

Frequency Coverage: L1/L2/G1/G2/E1/B1 + L-band

Antenna

Architecture Dual Frequency, RHCP Quadrifilar Helix

		Gain	Axial Ratio
		dBic typ. at Zenith	dB at Zenith
GNSS			
GPS	L1	3.3	≤ .5 max.
	L2	1.8	≤ .5 max.
	L5	-	-
GLONASS	G1	2.8	≤ .5 max.
	G2	1.5	≤ .5 max.
	G3	-	-
Galileo	E1	3.3	≤ .5 max.
	E5a	-	-
	E5b	-	-
	E6	-	-
BeiDou	B1	3.1	≤ .5 max.
	B2	-	-
	B3	-	-
IRNSS/NavIC	L5	-	-
QZSS	L6	-	-
L-band		2.9	≤ .5 max.
Satellite Communications			
	Iridium	-	-
	Globalstar	-	-

Mechanical

Mechanical Size 62.4 mm (H) x 44.5 mm (Dia)

Available Connectors SMA Male

Weight 37 g

Enclosure Radome and Base: EXL9330

Environmental

Operating Temp. Range ... -40°C to +85°C

Vibration 3-axis, sweep = 15 min, 10 to 200 Hz
sweep: 3 G

Shock Vertical axis: 50 G, other axes: 30 G

Compliance RoHS and REACH compliant

Other

Warranty One year – parts and labour

Low Noise Amplifier (LNA) (Measured a Vcc = 3V, Temperature=25°C)

Frequency Bandwidth ... 1525-1606 MHz, 1215-1254 MHz

Architecture Pre-filtered

Out-of-Band Rejection ... **L1/G1/B1/E1:**
 < 1400 MHz > 36 dB
 < 1450 MHz > 32 dB
 > 1700 MHz > 45 dB

L2/G2:
 < 1100 MHz > 35 dB
 < 1190 MHz > 47 dB
 < 1350 MHz > 48 dB

Gain 35 dB typ. 33 dB min. or
 28 dB typ. 26 dB min.

Noise Figure 2 dB typ.

VSWR <1.5:1 typ. 1.8:1 max.

Supply Voltage Range ... +2.2 to 12 VDC

Supply Current 12/18 mA typ. at 25°C.

ESD Circuit Protection ... 15 kV air discharge

EMI Immunity 50 V/m, excepting L1+/-100 MHz and L2
 +/- 100 MHz

HC872 Dimensions (mm)

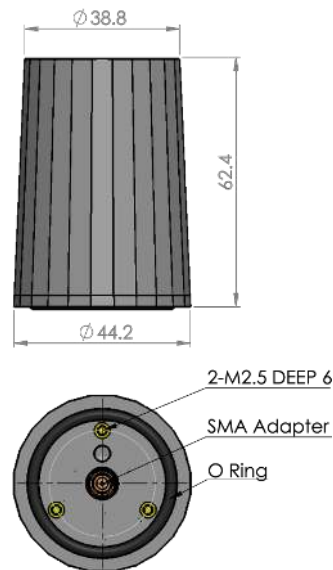

Ordering Information

HC872 - Dual Band Helical Antenna With L-band Services

Part Number: 33-HC872-xx, where xx = Gain in dB