

Metric

1 Type

- SG** Operation with star knob
- SK** Operation with wing knob
- ST** Operation with T-handle
- RG** Operation with GN 7336 hollow knurled knob
- KG** Operation with wing knob
- HG** Operation with lever
- LG** Operation with lever

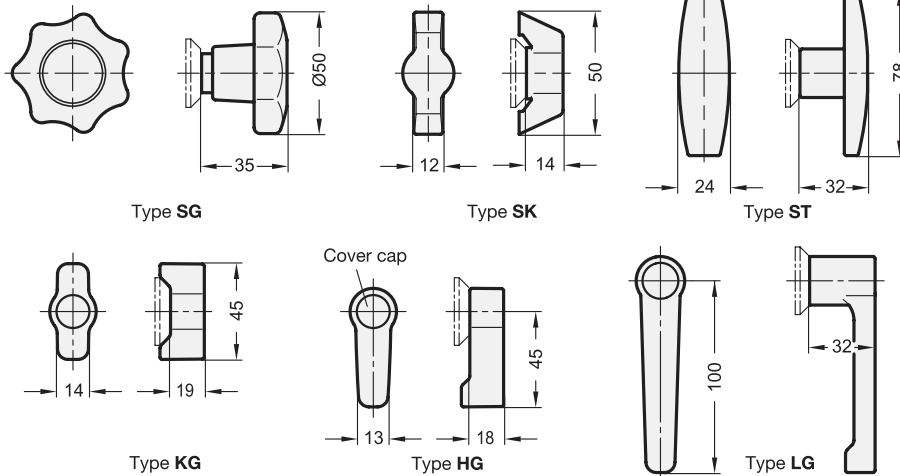

Metric table

2

Dimensions in: millimeters - inches

Latch distance A											d	h		
4	8	13	16	20	24	28	32	36	40	45	Type SG, RG, KG, HG	Type SK, ST, LG	Type SG, RG, KG, HG	Type SK, ST, LG
0.16	0.31	0.51	0.63	0.79	0.94	1.10	1.26	1.42	1.57	1.77	28	32	4	6
0.24	0.39	0.55	0.71	0.87	1.02	1.18	1.34	1.50	1.65	1.97	28	32	4	6

Specification

3

- Cam latch housing
Zinc die-cast
- Locating ring
 - Chrome plated finish —
 - Powder coated ● **SW**
- Latch arm / assembly hardware
Steel, zinc plated, blue passivated finish
- Operating elements
Plastic
Technopolymer (Polyamide PA)
 - Black, matte finish (Type SG, SK, ST, RG, KG, HG)
 - Zinc die-cast, powder coated Black, RAL 9005, textured finish (Type LG)
- Cover cap (Type RG, KG, HG, LG)
Plastic, Technopolymer (Polyamide PA)
Light gray
- RoHS compliant

Information

GN 115 cam latches close via a turning operation limited to 90° (quarter of a turn), which moves the latch arm behind the door frame. The beveled edges of the latch arm create a smooth latching of the door.

The 22 different off-set latch arm options allow for "Latch Distance A" to be set between 4 mm and 50 mm.

Products comes supplied with a loosely enclosed latch arm

see also...

- *List of Cam Latch Types*
- *Cam Locks GN 115 (Zinc Die-Cast, with Operating Elements)*
- *Cam Latches GN 115 (Zinc Die-Cast, Operation with Socket Key)*
- *Cam Latches GN 115 (Stainless Steel, Operation with Socket Key)*

How to order (Chrome plated locating ring)	1 Type
GN 115-SG-20	2 Latch distance A

How to order (Powder coated locating ring)	1 Type
GN 115-SU-18-SW	2 Latch distance A
	3 Finish (Locating ring)



- GN 115 Cam Latches (Zinc Die-Cast, with Operating Element)
- GN 115 Cam Latches (Zinc Die-Cast, Operation with Socket Key)
- GN 119.2 Socket Keys (Zinc Die-Cast)

Construction and assembly instructions

For installation, create a bore in the door as shown in the outline drawing.

Once assembled, the cam latch is inserted through the bore from the front. The hexagon jam nut can then be placed over the latch arm and onto the threaded housing and fastened in place.

The installation bore in the door leaf is usually generated by punching or laser machining during a mass production run.

For small production runs and steel sheets below 2 mm thickness, the GN 123 sheet metal punches are the tool of choice.

The installation bore can also be created by drilling / milling as shown in the outline drawings.

