

REVISIONS					
P	LTR	DESCRIPTION	DATE	DWN	APVD
M		REVISED PER ECO-20-000170	21MAY2020	KR	JO

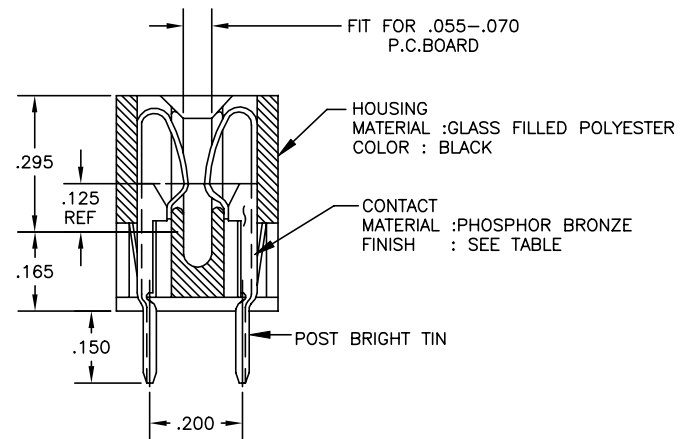

"AMP", PART NO. & DATE CODE INK STAMPED (WHITE OR HOT STAMP NO WHITE TAPE) IN THIS AREA. (SIDE OPTIONAL)

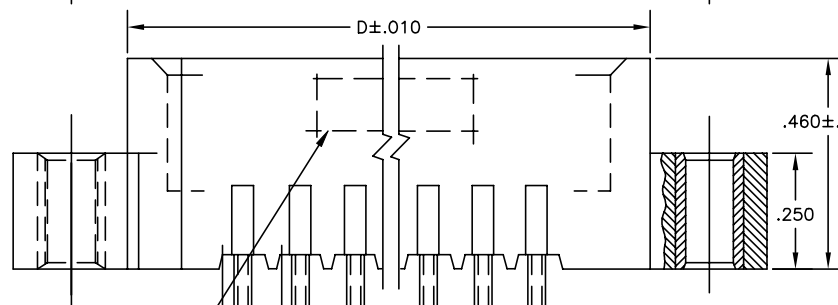
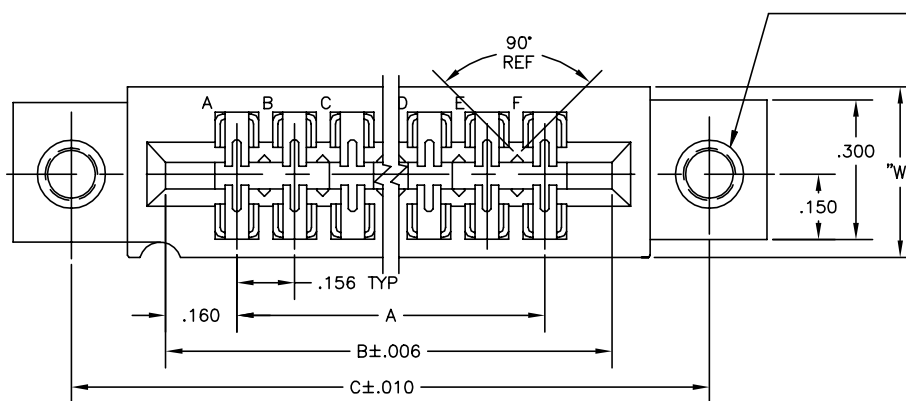
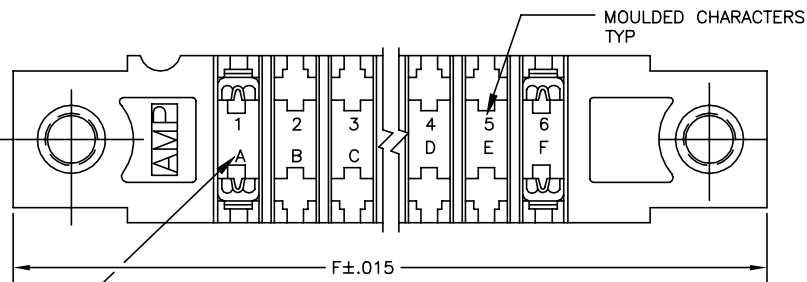

THIS DRAWING IS A CONTROLLED DOCUMENT.		DWN	15AUL75	TE Connectivity Ltd.
		CHK	15AUL75	
DIMENSIONS: INCHES		APVD	16AUL75	NAME
TOLERANCES UNLESS OTHERWISE SPECIFIED:				PRODUCT SPEC
0 PLC ± .005				APPLICATION SPEC
1 PLC ± -				SIZE
2 PLC ± -				CAGE CODE
3 PLC ± -				DRAWING NO
4 PLC ± -				RESTRICTED TO
ANGLES ± -				WEIGHT
FINISH				A2 00779 C=530677
MATERIAL SEE CALL-OUT				CUSTOMER DRAWING
SEE CALL-OUT				SCALE 5:1 SHEET 1 of 2 REV M

REVISIONS					
P	LTR	DESCRIPTION	DATE	DWN	APVD
-		SEE SHEET 1	-	-	-

- 1 .000015 MIN. GOLD OVER .000050 MIN. NICKEL IN CONTACT AREA
- 2 .000030 MIN. GOLD OVER .000050 MIN. NICKEL IN CONTACT AREA
- 3 ALL PARTS ASSEMBLED IN MEXICO MUST BE STAMPED "ASSY IN MEXICO"
THE WORD "MEXICO" CAN BE SUBSTITUTED ONLY WHERE PART SIZE
PROHIBITS STAMPING "ASSY IN MEXICO" INK STAMP COLOR WHITE OR HOT
STAMP (NO WHITE TAPE) 115-9009, APPROX. WHERE SHOWN, SIDE OPTIONAL.
- 4 MATTE TIN PLATED CONTACT TAILS

4	.437	8-530677-3	7.557	7.012	7.307	6.872	6.552	43	
4	.370	7-530677-4	3.189	2.644	2.939	2.504	2.184	15	
4	.370	7-530677-1	1.785	1.240	1.535	1.100	.780	6	
	.437	3-530677-3	7.557	7.012	7.307	6.872	6.552	43	1-530677-3
	.370	3-530677-2	5.217	4.672	4.967	4.532	4.212	28	1-530677-2
	.437	3-530677-1	7.713	7.168	7.463	7.028	6.708	44	1-530677-1
	.437	3-530677-0	6.465	5.920	6.215	5.780	5.460	36	1-530677-0
	.437	2-530677-9	5.529	4.984	5.279	4.844	4.524	30	530677-9
	.370	2-530677-8	4.749	4.204	4.499	4.064	3.744	25	530677-8
	.370	2-530677-7	4.593	4.048	4.343	3.908	3.588	24	530677-7
	.370	2-530677-6	4.281	3.736	4.031	3.596	3.276	22	530677-6
	.370	2-530677-5	3.657	3.112	3.407	2.972	2.652	18	530677-5
	.370	2-530677-4	3.189	2.644	2.939	2.504	2.184	15	530677-4
	.370	2-530677-3	3.721	2.176	2.471	2.036	1.716	12	530677-3
	.370	2-530677-2	2.409	1.864	2.159	1.724	1.404	10	530677-2
	.370	2-530677-1	1.785	1.240	1.535	1.100	.780	6	530677-1
	W	PART NO. 2	F	D	C	B	A	NO OF POSN.	1 PART NO.

OBSOLETE

530677

THIS DRAWING IS A CONTROLLED DOCUMENT.		DWN	15A/L75	 TE Connectivity Ltd.
		GK	15A/L75	
DIMENSIONS: INCHES		APVD	16A/L75	NAME
TOLERANCES UNLESS OTHERWISE SPECIFIED:		PRODUCT SPEC		
0 PLC ± .005		APPLICATION SPEC		
1 PLC ± -		SIZE		
2 PLC ± -		CAGE CODE		
3 PLC ± -		DRAWING NO		
4 PLC ± -		RESTRICTED TO		
ANGLES ± -		A2 00779 C=530677		
FINISH		WEIGHT		
-		CUSTOMER DRAWING		
		SCALE 5:1		SHEET 2 of 2
				REV M