

TPS51916 Complete DDR2, DDR3, DDR3L and DDR4 Memory Power Solution

Synchronous Buck Controller, 2-A LDO, Buffered Reference

1 Features

- Synchronous Buck Controller (VDDQ)
 - Conversion Voltage Range: 3 V to 28 V
 - Output Voltage Range: 0.7 V to 1.8 V
 - 0.8% V_{REF} Accuracy
 - Selectable Control Architecture
 - D-CAP™ Mode for Fast Transient Response
 - D-CAP2™ Mode for Ceramic Output Capacitors
 - Selectable 300 kHz, 400 kHz, 500 kHz, or 670 kHz Switching Frequencies
 - Optimized Efficiency at Light and Heavy Loads with Auto-skip Function
 - Supports Soft-Off in S4 and S5 States
 - OCL/OVP/UVLP/UVLO Protections
 - Powergood Output
- 2-A LDO(VTT), Buffered Reference(VTTREF)
 - 2-A (Peak) Sink and Source Current
 - Buffered, Low Noise, 10-mA VTTREF Output
 - 0.8% VTTREF, 20-mV VTT Accuracy
 - Supports High-Z (S3) and Soft-Off (S4, S5)
- Thermal Shutdown
- 20-Pin, 3 mm × 3 mm, QFN Package
- Create a [WEBENCH](#) Design

2 Applications

- Memory Power Supplies: DDR2, DDR3, DDR3L, DDR4
- Termination: SSTL_18, SSTL_15, SSTL_135, HSTL

3 Description

The TPS51916 device provides a complete power supply for DDR2, DDR3, DDR3L, and DDR4 memory systems in the lowest total cost and minimum space. It integrates a synchronous buck regulator controller (VDDQ) with a 2-A sink and 2-A source tracking LDO (VTT) and buffered low noise reference (VTTREF).

The device employs D-CAP™ mode coupled with 300 kHz or 400 kHz frequencies for ease-of-use and fast transient response or D-CAP2™ mode coupled with higher 500 kHz or 670 kHz frequencies to support ceramic output capacitor without an external compensation circuit. The VTTREF tracks VDDQ/2 within excellent 0.8% accuracy. The VTT, which provides 2-A sink and 2-A source peak current capabilities, requires only 10- μ F of ceramic capacitance. A dedicated LDO supply input is available.

The device also provides excellent power supply performance. It supports flexible power state control, placing VTT at high-Z in S3 and discharging VDDQ, VTT and VTTREF (soft-off) in S4 or S5 state. Programmable OCL with low-side MOSFET $R_{DS(on)}$ sensing, OVP, UVP, UVLO and thermal shutdown protections are also available.

Device Information⁽¹⁾

PART NUMBER	PACKAGE	BODY SIZE (NOM)
TPS51916	QFN (20)	3 mm × 3 mm

(1) For all available packages, see the orderable addendum at the end of the data sheet.

Simplified Application

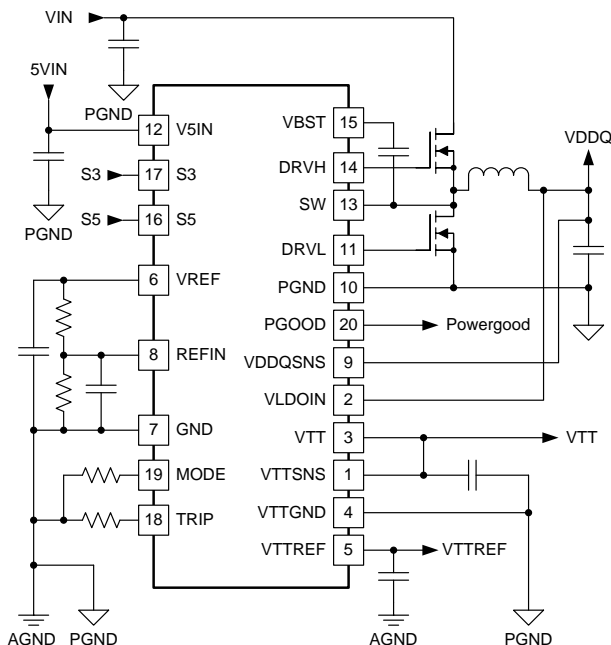

Table of Contents

1 Features	1	7.4 Device Functional Modes.....	20
2 Applications	1	7.5 D-CAP2™ Mode Operation	22
3 Description	1	8 Application and Implementation	23
4 Revision History	2	8.1 Application Information.....	23
5 Pin Configuration and Functions	3	9 Power Supply Recommendations	28
6 Specifications	4	10 Layout	28
6.1 Absolute Maximum Ratings	4	10.1 Layout Guidelines	28
6.2 ESD Ratings.....	4	10.2 Layout Example	31
6.3 Recommended Operating Conditions.....	5	11 Device and Documentation Support	32
6.4 Thermal Information	5	11.1 Receiving Notification of Documentation Updates	32
6.5 Electrical Characteristics.....	6	11.2 Community Resources.....	32
6.6 Typical Characteristics	9	11.3 Trademarks	32
7 Detailed Description	15	11.4 Electrostatic Discharge Caution.....	32
7.1 Overview	15	11.5 Glossary	32
7.2 Functional Block Diagram	15	12 Mechanical, Packaging, and Orderable	
7.3 Feature Description.....	16	Information	32

4 Revision History

Changes from Revision E (August 2016) to Revision F Page

- Changed *VLDOIN discharge current* test condition from "Non-tracking" to "Tracking" in [Electrical Characteristics](#) table **6**

Changes from Revision D (June 2012) to Revision E Page

- Added *Pin Configuration and Functions* section, *ESD Rating* table, *Feature Description* section, *Device Functional Modes*, *Application and Implementation* section, *Power Supply Recommendations* section, *Layout* section, *Device and Documentation Support* section, *Receiving Notification of Documentation Updates* section, *Community Resources* section, and *Mechanical, Packaging, and Orderable Information* section, and *Mechanical, Packaging, and Orderable Information* section
- Changed Minimum S3 or S5 high-level voltage from "1.8 V" to "1.5 V" in [Electrical Characteristics](#) table

Changes from Revision C (March 2012) to Revision D Page

- Added clarity to
- Added more information to [VTT and VTTREF](#) section.
- Added clarity to [Figure 38](#).....

5 Pin Configuration and Functions

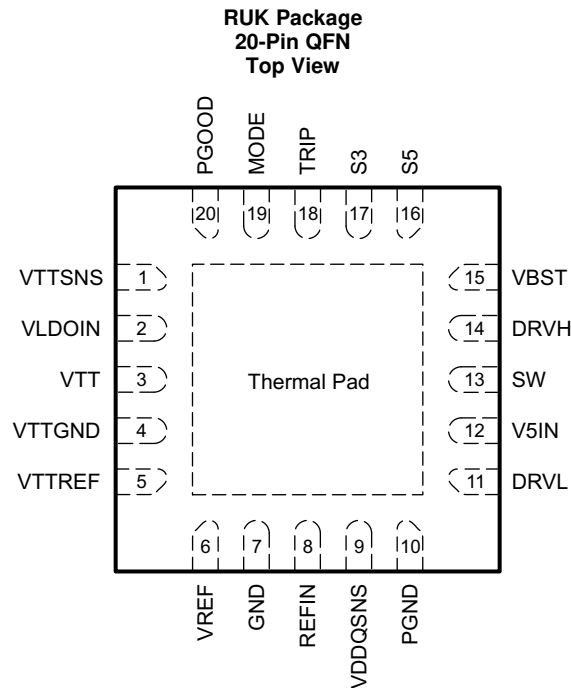

Pin Functions

PIN		I/O	DESCRIPTION
NAME	NO.		
DRVH	14	O	High-side MOSFET gate driver output.
DRVH	11	O	Low-side MOSFET gate driver output.
GND	7	–	Signal ground.
MODE	19	I	Connect resistor to GND to configure switching frequency, control mode and discharge mode. (See Table 2)
PGND	10	–	Gate driver power ground. $R_{DS(on)}$ current sensing input(+).
PGOOD	20	O	Powergood signal open drain output. PGOOD goes high when VDDQ output voltage is within the target range.
REFIN	8	I	Reference input for VDDQ. Connect to the midpoint of a resistor divider from VREF to GND. Add a capacitor for stable operation.
SW	13	I/O	High-side MOSFET gate driver return. $R_{DS(on)}$ current sensing input(-).
S3	17	I	S3 signal input. (See Table 1)
S5	16	I	S5 signal input. (See Table 1)
TRIP	18	I	Connect resistor to GND to set OCL at $V_{TRIP}/8$. Output 10- μ A current at room temperature, $T_C = 4700$ ppm/ $^{\circ}$ C.
VBST	15	I	High-side MOSFET gate driver bootstrap voltage input. Connect a capacitor from the VBST pin to the SW pin.
VDDQSNS	9	I	VDDQ output voltage feedback. Reference input for VTTREF. Also serves as power supply for VTTREF.
VLDOIN	2	I	Power supply input for VTT LDO. Connect VDDQ in typical application.
VREF	6	O	1.8-V reference output.
VTT	3	O	VTT 2-A LDO output. Need to connect at least 10 μ F of capacitance for stability.
VTTGND	4	–	Power ground for VTT LDO.
VTTREF	5	O	Buffered VTT reference output. Need to connect 0.22 μ F or larger capacitance for stability.
VTTSENS	1	I	VTT output voltage feedback.
V5IN	12	I	5-V power supply input for internal circuits and MOSFET gate drivers.
Thermal pad	–	–	Thermal pad. Connect directly to system GND plane with multiple vias.

6 Specifications

6.1 Absolute Maximum Ratings

over operating free-air temperature range (unless otherwise noted)⁽¹⁾

		MIN	MAX	UNIT
Input voltage ⁽²⁾	VBST	−0.3	36	V
	VBST ⁽³⁾	−0.3	6	
	SW	−5	30	
	VLDOIN, VDDQSNS, REFIN	−0.3	3.6	
	VTTSENS	−0.3	3.6	
	PGND, VTTGND	−0.3	0.3	
	V5IN, S3, S5, TRIP, MODE	−0.3	6	
Output voltage ⁽²⁾	DRVH	−5	36	V
	DRVH ⁽³⁾	−0.3	6	
	VTTREF, VREF	−0.3	3.6	
	VTT	−0.3	3.6	
	DRVL	−0.3	6	
	PGOOD	−0.3	6	
Junction temperature, T _J			125	°C
Storage temperature, T _{STG}		−55	150	°C

(1) Stresses beyond those listed under *Absolute Maximum Ratings* may cause permanent damage to the device. These are stress ratings only, which do not imply functional operation of the device at these or any other conditions beyond those indicated under *Recommended Operating Conditions*. Exposure to absolute-maximum-rated conditions for extended periods may affect device reliability.

(2) All voltage values are with respect to the network ground terminal unless otherwise noted.

(3) Voltage values are with respect to the SW terminal.

6.2 ESD Ratings

		VALUE	UNIT
V _(ESD)	Electrostatic discharge	Human-body model (HBM), per ANSI/ESDA/JEDEC JS-001 ⁽¹⁾	±2000
		Charged-device model (CDM), per JEDEC specification JESD22-C101 ⁽²⁾	±1500

(1) JEDEC document JEP155 states that 500-V HBM allows safe manufacturing with a standard ESD control process.

(2) JEDEC document JEP157 states that 250-V CDM allows safe manufacturing with a standard ESD control process.

6.3 Recommended Operating Conditions

over operating free-air temperature range (unless otherwise noted)

		MIN	NOM	MAX	UNIT
Supply voltage	V5IN	4.5		5.5	V
Input voltage	VBST	-0.1		33.5	V
	VBST	-0.1		5.5	
	SW	-3		28	
	SW	-4.5		28	
	VLDOIN, VDDQSNS, REFIN	-0.1		3.5	
	VTTSENS	-0.1		3.5	
	PGND, VTTGND	-0.1		0.1	
Output voltage	S3, S5, TRIP, MODE	-0.1		5.5	V
	DRVH	-3		33.5	
	DRVH-SW	-0.1		5.5	
	DRVH (less than 30% of repetitive period)	-4.5		33.5	
	VTTREF, VREF	-0.1		3.5	
	VTT	-0.1		3.5	
	DRVL	-0.1		5.5	
PGOOD	-0.1		5.5		
T _A	Ambient temperature	-40		85	°C

6.4 Thermal Information

THERMAL METRIC ⁽¹⁾		TPS51916	UNIT
		RUK (QFN)	
		20 PINS	
R _{θJA}	Junction-to-ambient thermal resistance	94.1	°C/W
R _{θJC(top)}	Junction-to-case (top) thermal resistance	58.1	°C/W
R _{θJB}	Junction-to-board thermal resistance	64.3	°C/W
ψ _{JT}	Junction-to-top characterization parameter	31.8	°C/W
ψ _{JB}	Junction-to-board characterization parameter	58.0	°C/W
R _{θJC(bot)}	Junction-to-case (bottom) thermal resistance	5.9	°C/W

- (1) For more information about traditional and new thermal metrics, see the [Semiconductor and IC Package Thermal Metrics](#) application report.

6.5 Electrical Characteristics

over operating free-air temperature range, $V_{V5IN} = 5\text{ V}$, VLDOIN is connected to VDDQ output, $V_{MODE} = 0\text{ V}$, $V_{S3} = V_{S5} = 5\text{ V}$ (unless otherwise noted)

PARAMETER		TEST CONDITION	MIN	TYP	MAX	UNIT
SUPPLY CURRENT						
$I_{V5IN(S0)}$	V5IN supply current, in S0	$T_A = 25^\circ\text{C}$, No load, $V_{S3} = V_{S5} = 5\text{ V}$		590		μA
$I_{V5IN(S3)}$	V5IN supply current, in S3	$T_A = 25^\circ\text{C}$, No load, $V_{S3} = 0\text{ V}$, $V_{S5} = 5\text{ V}$		500		μA
$I_{V5INSDN}$	V5IN shutdown current	$T_A = 25^\circ\text{C}$, No load, $V_{S3} = V_{S5} = 0\text{ V}$			1	μA
$I_{VLDOIN(S0)}$	VLDOIN supply current, in S0	$T_A = 25^\circ\text{C}$, No load, $V_{S3} = V_{S5} = 5\text{ V}$			5	μA
$I_{VLDOIN(S3)}$	VLDOIN supply current, in S3	$T_A = 25^\circ\text{C}$, No load, $V_{S3} = 0\text{ V}$, $V_{S5} = 5\text{ V}$			5	μA
$I_{VLDOINSDN}$	VLDOIN shutdown current	$T_A = 25^\circ\text{C}$, No load, $V_{S3} = V_{S5} = 0\text{ V}$			5	μA
VREF OUTPUT						
V_{VREF}	Output voltage	$I_{VREF} = 30\ \mu\text{A}$, $T_A = 25^\circ\text{C}$		1.8000		V
		$0\ \mu\text{A} \leq I_{VREF} < 300\ \mu\text{A}$, $T_A = -10^\circ\text{C}$ to 85°C	1.7856		1.8144	
		$0\ \mu\text{A} \leq I_{VREF} < 300\ \mu\text{A}$, $T_A = -40^\circ\text{C}$ to 85°C	1.7820		1.8180	
$I_{VREFOCL}$	Current limit	$V_{VREF} = 1.7\text{ V}$	0.4	0.8		mA
VTTREF OUTPUT						
V_{VTTREF}	Output voltage			$V_{VDDQSNS}/2$		V
V_{VTTREF}	Output voltage tolerance to V_{VDDQ}	$ I_{VTTREF} < 100\ \mu\text{A}$, $1.2\text{ V} \leq V_{VDDQSNS} \leq 1.8\text{ V}$	49.2%		50.8%	
		$ I_{VTTREF} < 10\ \text{mA}$, $1.2\text{ V} \leq V_{VDDQSNS} \leq 1.8\text{ V}$	49%		51%	
$I_{VTTREFOCLSRC}$	Source current limit	$V_{VDDQSNS} = 1.8\text{ V}$, $V_{VTTREF} = 0\text{ V}$	10	18		mA
$I_{VTTREFOCLSNK}$	Sink current limit	$V_{VDDQSNS} = 1.8\text{ V}$, $V_{VTTREF} = 1.8\text{ V}$	10	17		mA
$I_{VTTREFDIS}$	VTTREF discharge current	$T_A = 25^\circ\text{C}$, $V_{S3} = V_{S5} = 0\text{ V}$, $V_{VTTREF} = 0.5\text{ V}$	0.8	1.3		mA
VTT OUTPUT						
V_{VTT}	Output voltage			V_{VTTREF}		V
V_{VTTTOL}	Output voltage tolerance to VTTREF	$ I_{VTT} \leq 10\ \text{mA}$, $1.2\text{ V} \leq V_{VDDQSNS} \leq 1.8\text{ V}$, $I_{VTTREF} = 0\ \text{A}$	-20		20	mV
		$ I_{VTT} \leq 1\ \text{A}$, $1.2\text{ V} \leq V_{VDDQSNS} \leq 1.8\text{ V}$, $I_{VTTREF} = 0\ \text{A}$	-30		30	
		$ I_{VTT} \leq 2\ \text{A}$, $1.4\text{ V} \leq V_{VDDQSNS} \leq 1.8\text{ V}$, $I_{VTTREF} = 0\ \text{A}$	-40		40	
		$ I_{VTT} \leq 1.5\ \text{A}$, $1.2\text{ V} \leq V_{VDDQSNS} \leq 1.4\text{ V}$, $I_{VTTREF} = 0\ \text{A}$	-40		40	
$I_{VTTOCLSRC}$	Source current limit	$V_{VDDQSNS} = 1.8\text{ V}$, $V_{VTT} = V_{VTTNS} = 0.7\text{ V}$, $I_{VTTREF} = 0\ \text{A}$	2	3		A
$I_{VTTOCLSNK}$	Sink current limit	$V_{VDDQSNS} = 1.8\text{ V}$, $V_{VTT} = V_{VTTNS} = 1.1\text{ V}$, $I_{VTTREF} = 0\ \text{A}$	2	3		A
I_{VTTLK}	Leakage current	$T_A = 25^\circ\text{C}$, $V_{S3} = 0\text{ V}$, $V_{S5} = 5\text{ V}$, $V_{VTT} = V_{VTTREF}$			5	μA
$I_{VTTNSBIAS}$	VTTNS input bias current	$V_{S3} = 5\text{ V}$, $V_{S5} = 5\text{ V}$, $V_{VTTNS} = V_{VTTREF}$	-0.5	0.0	0.5	μA
$I_{VTTNSLK}$	VTTNS leakage current	$V_{S3} = 0\text{ V}$, $V_{S5} = 5\text{ V}$, $V_{VTTNS} = V_{VTTREF}$	-1	0	1	μA
I_{VTTDIS}	VTT Discharge current	$T_A = 25^\circ\text{C}$, $V_{S3} = V_{S5} = 0\text{ V}$, $V_{VDDQSNS} = 1.8\text{ V}$, $V_{VTT} = 0.5\text{ V}$, $I_{VTTREF} = 0\ \text{A}$		7.8		mA
VDDQ OUTPUT						
$V_{VDDQSNS}$	VDDQ sense voltage			V_{REFIN}		
$V_{VDDQSNSSTOL}$	VDDQSNS regulation voltage tolerance to REFIN	$T_A = 25^\circ\text{C}$	-3		3	mV
$I_{VDDQSNS}$	VDDQSNS input current	$V_{VDDQSNS} = 1.8\text{ V}$		39		μA
I_{REFIN}	REFIN input current	$V_{REFIN} = 1.8\text{ V}$	-0.1	0.0	0.1	μA
$I_{VDDQDIS}$	VDDQ discharge current	$V_{S3} = V_{S5} = 0\text{ V}$, $V_{VDDQSNS} = 0.5\text{ V}$, MODE pin pulled down to GND through 47 k Ω (Non-tracking)		12		mA
$I_{VLDOINDIS}$	VLDOIN discharge current	$V_{S3} = V_{S5} = 0\text{ V}$, $V_{VDDQSNS} = 0.5\text{ V}$, MODE pin pulled down to GND through 100 k Ω (Tracking)		1.2		A

Electrical Characteristics (continued)

over operating free-air temperature range, $V_{V5IN} = 5\text{ V}$, VLDOIN is connected to VDDQ output, $V_{MODE} = 0\text{ V}$, $V_{S3} = V_{S5} = 5\text{ V}$ (unless otherwise noted)

PARAMETER	TEST CONDITION	MIN	TYP	MAX	UNIT		
SWITCH MODE POWER SUPPLY (SMPS) FREQUENCY							
f_{SW}	VDDQ switching frequency	$V_{IN} = 12\text{ V}$, $V_{VDDQSNS} = 1.8\text{ V}$, $R_{MODE} = 100\text{ k}\Omega$	300		kHz		
		$V_{IN} = 12\text{ V}$, $V_{VDDQSNS} = 1.8\text{ V}$, $R_{MODE} = 200\text{ k}\Omega$	400				
		$V_{IN} = 12\text{ V}$, $V_{VDDQSNS} = 1.8\text{ V}$, $R_{MODE} = 1\text{ k}\Omega$	500				
		$V_{IN} = 12\text{ V}$, $V_{VDDQSNS} = 1.8\text{ V}$, $R_{MODE} = 12\text{ k}\Omega$	670				
$t_{ON(min)}$	Minimum on-time ⁽¹⁾	DRVH rising to falling		60	ns		
$t_{OFF(min)}$	Minimum off-time	DRVH falling to rising		200 320 450			
VDDQ MOSFET DRIVER							
R_{DRVH}	DRVH resistance	Source, $I_{DRVH} = -50\text{ mA}$	1.6	3.0	Ω		
		Sink, $I_{DRVH} = 50\text{ mA}$	0.6	1.5			
R_{DRVL}	DRVL resistance	Source, $I_{DRVL} = -50\text{ mA}$	0.9	2.0	Ω		
		Sink, $I_{DRVL} = 50\text{ mA}$	0.5	1.2			
t_{DEAD}	Dead time	DRVH-off to DRVL-on	10		ns		
		DRVL-off to DRVH-on	20				
INTERNAL BOOT STRAP SW							
V_{FBST}	Forward voltage	$V_{V5IN-VBST}$, $T_A = 25^\circ\text{C}$, $I_F = 10\text{ mA}$		0.1	0.2	V	
I_{VBSTLK}	VBST leakage current	$T_A = 25^\circ\text{C}$, $V_{VBST} = 33\text{ V}$, $V_{SW} = 28\text{ V}$		0.01	1.5	μA	
LOGIC THRESHOLD							
I_{MODE}	MODE source current		14	15	16	μA	
V_{THMODE}	MODE threshold voltage	MODE 0-1	109	129	149	mV	
		MODE 1-2	235	255	275		
		MODE 2-3	392	412	432		
		MODE 3-4	580	600	620		
		MODE 4-5	829	854	879		
		MODE 5-6	1202	1232	1262		
		MODE 6-7	1760	1800	1840		
V_{IL}	S3 or S5 low-level voltage				0.5	V	
V_{IH}	S3 or S5 high-level voltage	1.5					
V_{IHYST}	S3 or S5 hysteresis voltage		0.25				
I_{ILK}	S3 or S5 input leak current	-1	0	1	μA		
SOFT START							
t_{SS}	VDDQ soft-start time	Internal soft-start time, $C_{VREF} = 0.1\text{ }\mu\text{F}$, S5 rising to $V_{VDDQSNS} > 0.99 \times V_{REFIN}$		1.1		ms	
PGOOD COMPARATOR							
V_{THPG}	VDDQ PGOOD threshold	PGOOD in from higher	106%	108%	110%	μA	
		PGOOD in from lower	90%	92%	94%		
		PGOOD out to higher	114%	116%	118%		
		PGOOD out to lower	82%	84%	86%		
I_{PG}	PGOOD sink current	$V_{PGOOD} = 0.5\text{ V}$		3	5.9	mA	
t_{PGDLY}	PGOOD delay time	Delay for PGOOD in		0.8	1	1.2	ms
		Delay for PGOOD out, with 100 mV over drive			330		ns
$t_{PGSSDLY}$	PGOOD start-up delay	$C_{VREF} = 0.1\text{ }\mu\text{F}$, S5 rising to PGOOD rising			2.5	ms	

(1) Ensured by design. Not production tested.

Electrical Characteristics (continued)

over operating free-air temperature range, $V_{V5IN} = 5\text{ V}$, VLDOIN is connected to VDDQ output, $V_{MODE} = 0\text{ V}$, $V_{S3} = V_{S5} = 5\text{ V}$ (unless otherwise noted)

PARAMETER		TEST CONDITION	MIN	TYP	MAX	UNIT
PROTECTIONS						
I_{TRIP}	TRIP source current	$T_A = 25^\circ\text{C}$, $V_{TRIP} = 0.4\text{ V}$	9	10	11	μA
T_{CITRIP}	TRIP source current temperature coefficient ⁽¹⁾			4700		ppm/ $^\circ\text{C}$
V_{TRIP}	V_{TRIP} voltage range		0.2		3	V
V_{OCL}	Current limit threshold	$V_{TRIP} = 3.0\text{ V}$	360	375	390	mV
		$V_{TRIP} = 1.6\text{ V}$	190	200	210	
		$V_{TRIP} = 0.2\text{ V}$	20	25	30	
V_{OCLN}	Negative current limit threshold	$V_{TRIP} = 3.0\text{ V}$	-390	-375	-360	mV
		$V_{TRIP} = 1.6\text{ V}$	-210	-200	-190	
		$V_{TRIP} = 0.2\text{ V}$	-30	-25	-20	
V_{ZC}	Zero cross detection offset			0		mV
V_{UVLO}	V5IN UVLO threshold voltage	Wake-up	4.2	4.4	4.5	V
		Shutdown	3.7	3.9	4.1	
V_{OVP}	VDDQ OVP threshold voltage	OVP detect voltage	118%	120%	122%	
t_{OVDPDY}	VDDQ OVP propagation delay	With 100 mV over drive		430		ns
V_{UVP}	VDDQ UVP threshold voltage	UVP detect voltage	66%	68%	70%	
t_{UVPDY}	VDDQ UVP delay			1		ms
$t_{UVPENDLY}$	VDDQ UVP enable delay			1.2		ms
V_{OOB}	OOB Threshold voltage			108%		
THERMAL SHUTDOWN						
T_{SDN}	Thermal shutdown threshold ⁽¹⁾	Shutdown temperature		140		$^\circ\text{C}$
		Hysteresis		10		

6.6 Typical Characteristics

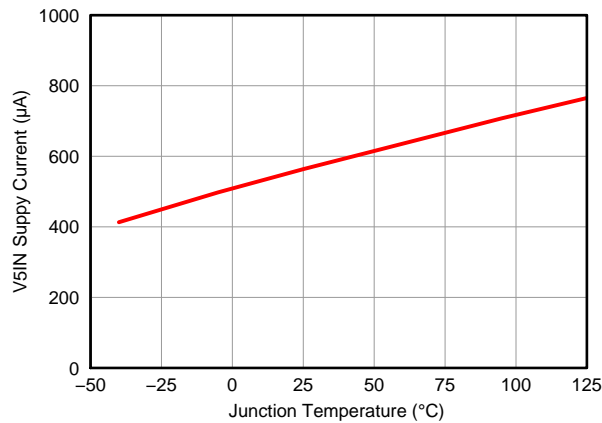

Figure 1. V5IN Supply Current vs Junction Temperature

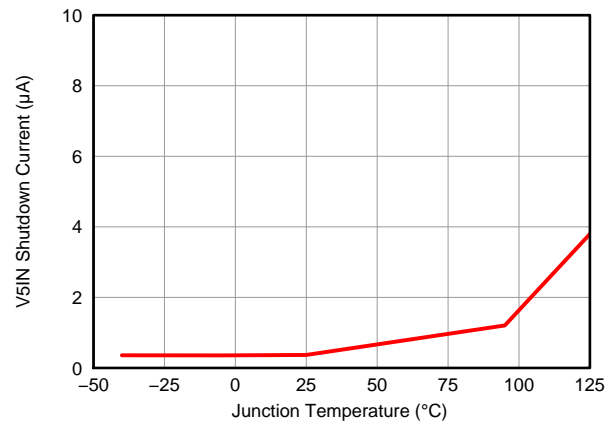

Figure 2. V5IN Shutdown Current vs Junction Temperature

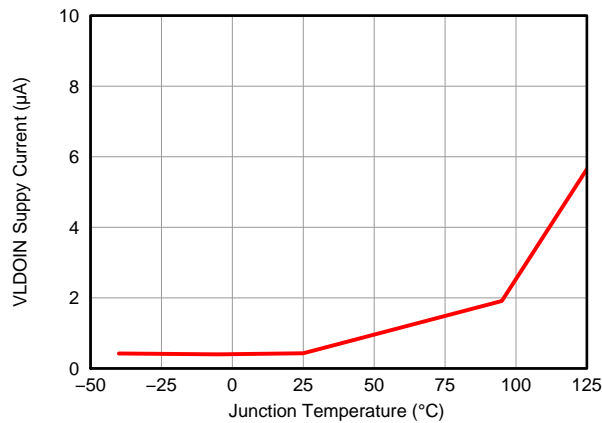

Figure 3. VLDOIN Supply Current vs Junction Temperature

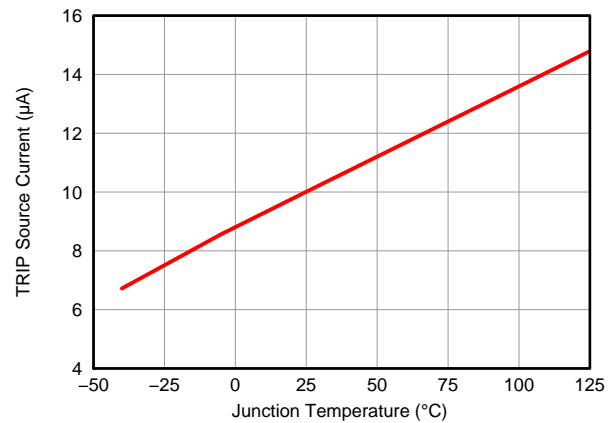

Figure 4. Current Sense Current vs Junction Temperature

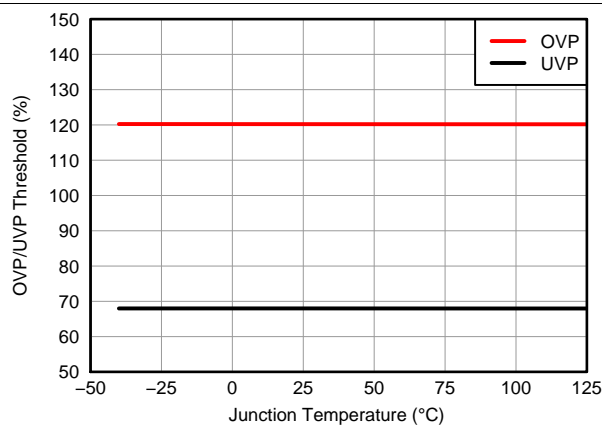

Figure 5. OVP/UVP Threshold vs Junction Temperature

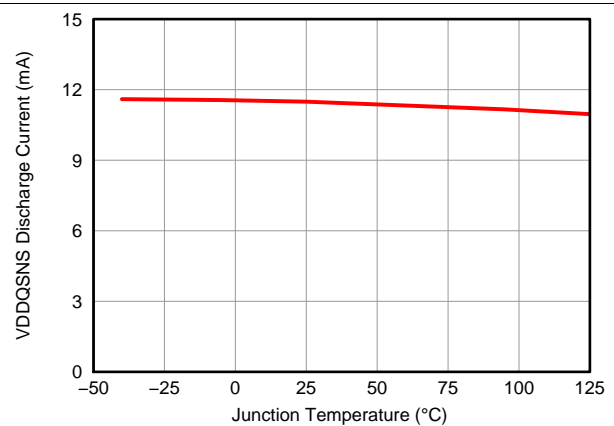

Figure 6. VDDQSNS Discharge Current vs Junction Temperature

Typical Characteristics (continued)

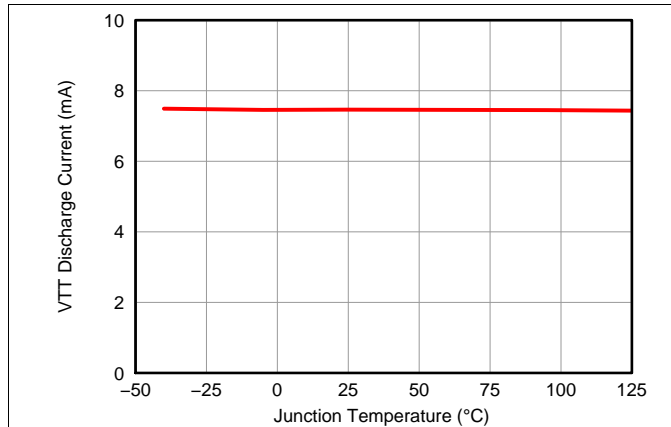

Figure 7. VTT Discharge Current vs Junction Temperature

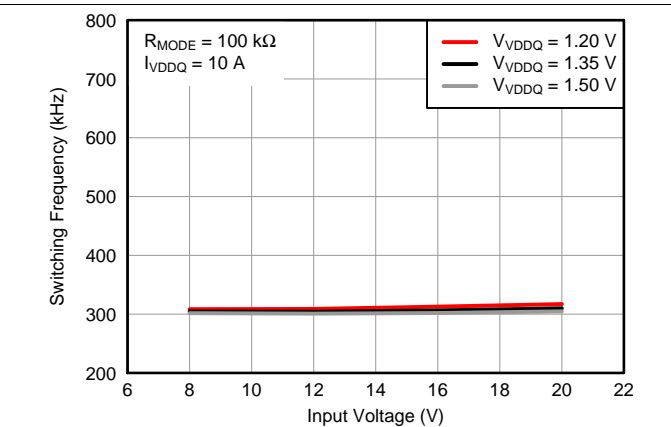

Figure 8. Switching Frequency vs Input Voltage

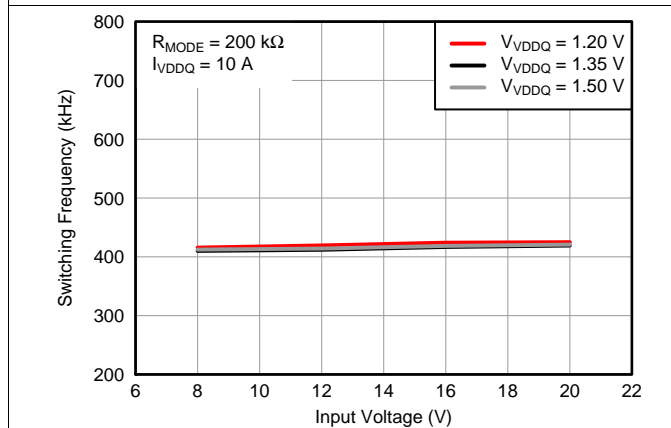

Figure 9. Switching Frequency vs Input Voltage

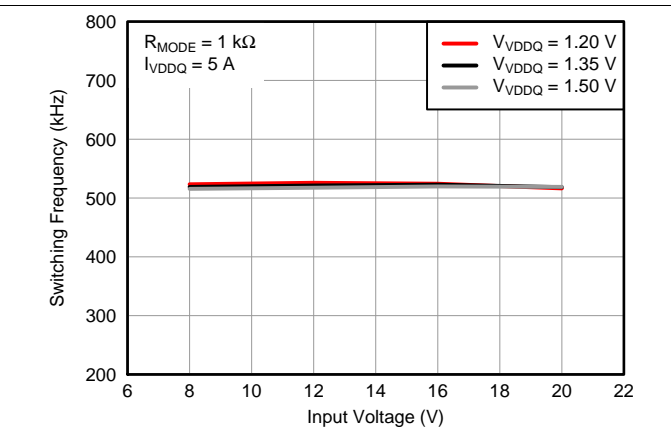

Figure 10. Switching Frequency vs Input Voltage

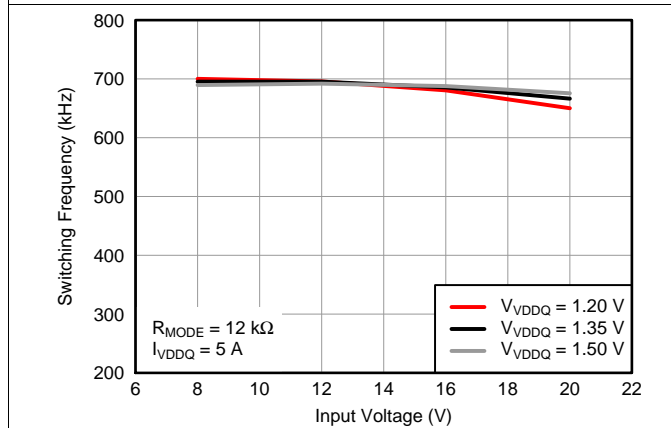

Figure 11. Switching Frequency vs Input Voltage

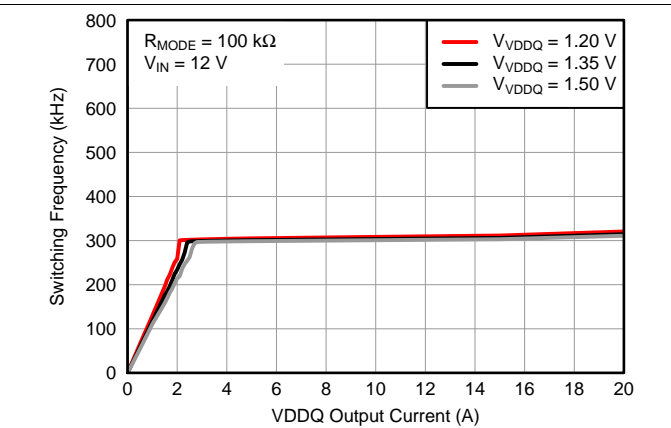

Figure 12. Switching Frequency vs Load Current

Typical Characteristics (continued)

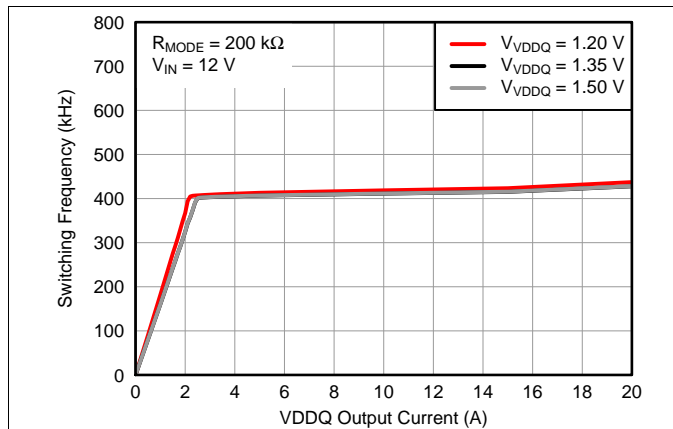

Figure 13. Switching Frequency vs Load Current

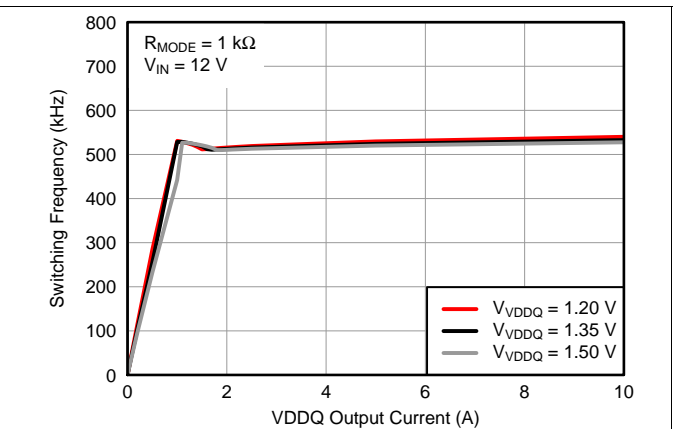

Figure 14. Switching Frequency vs Load Current

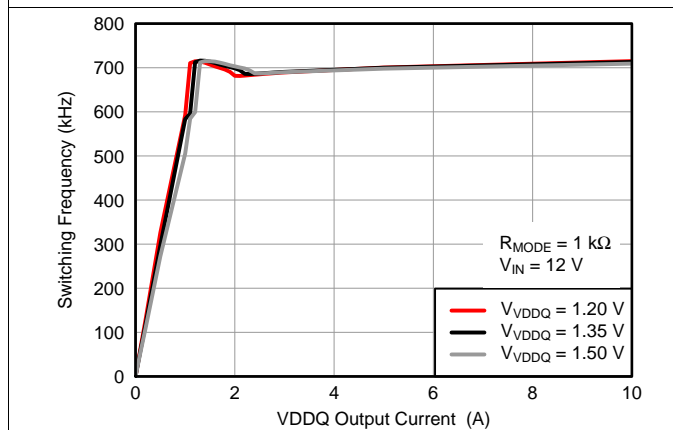

Figure 15. Switching Frequency vs Load Current

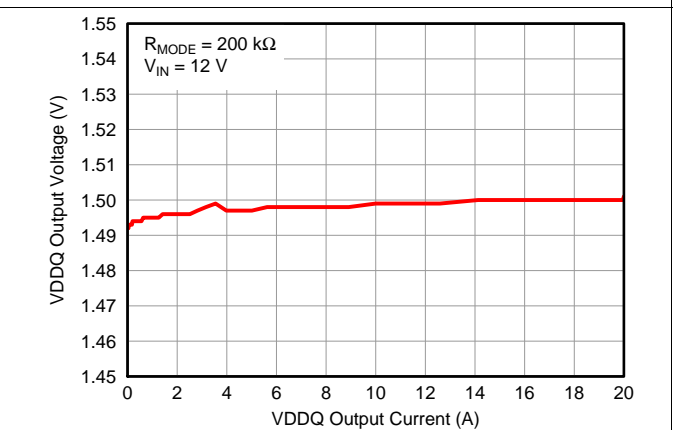

Figure 16. Load Regulation

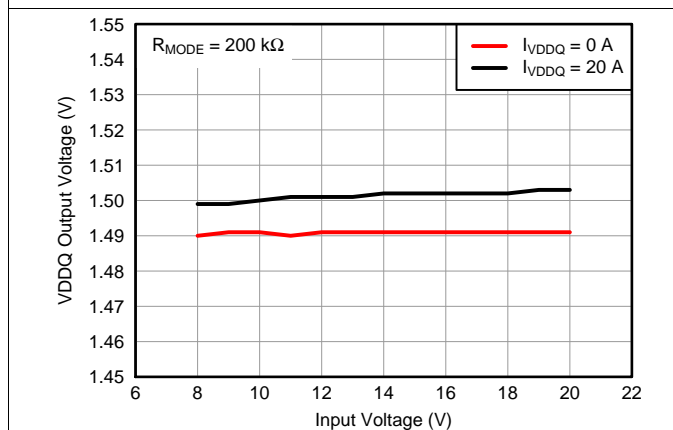

Figure 17. Line Regulation

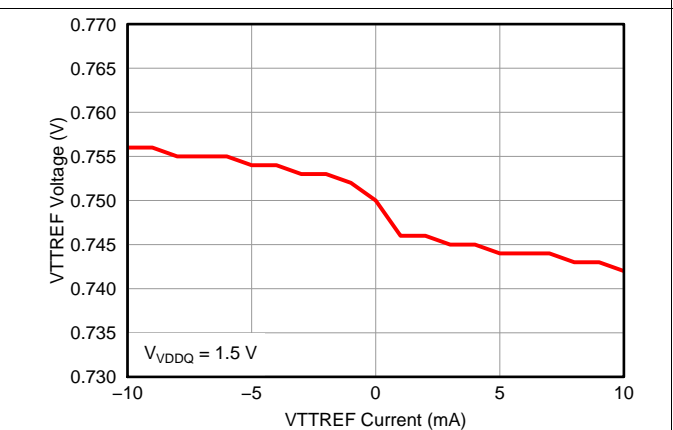

Figure 18. VTTREF Load Regulation

Typical Characteristics (continued)

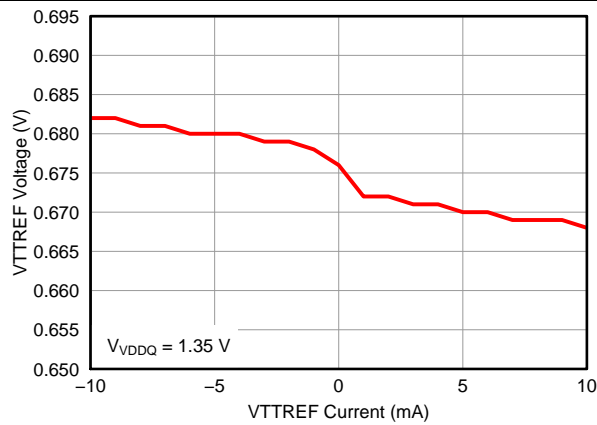

Figure 19. VTTREF Load Regulation

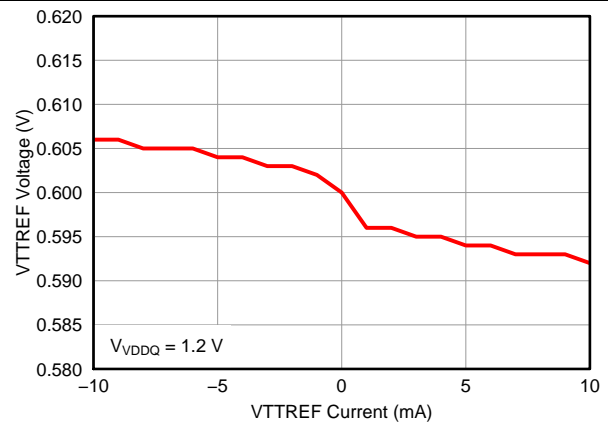

Figure 20. VTTREF Load Regulation

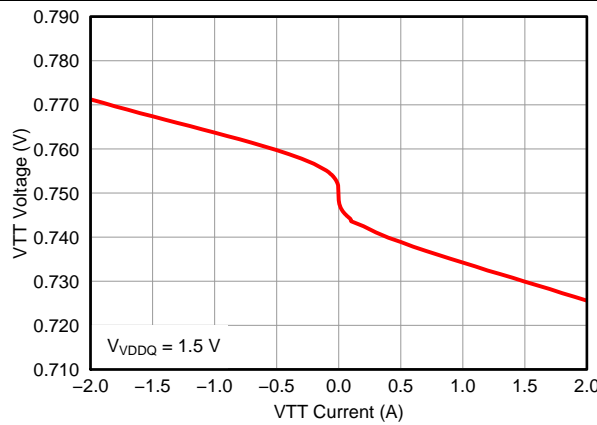

Figure 21. VTT Load Regulation

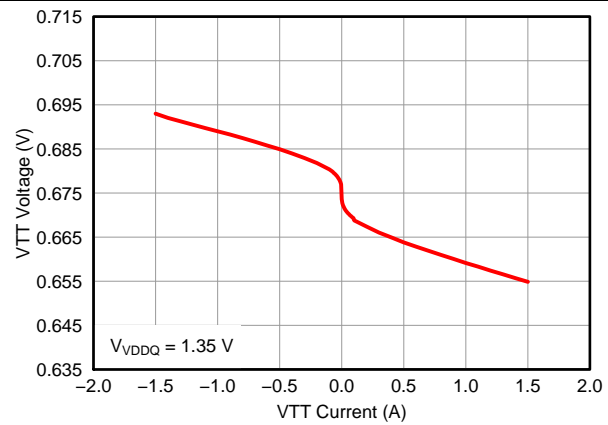

Figure 22. VTT Load Regulation

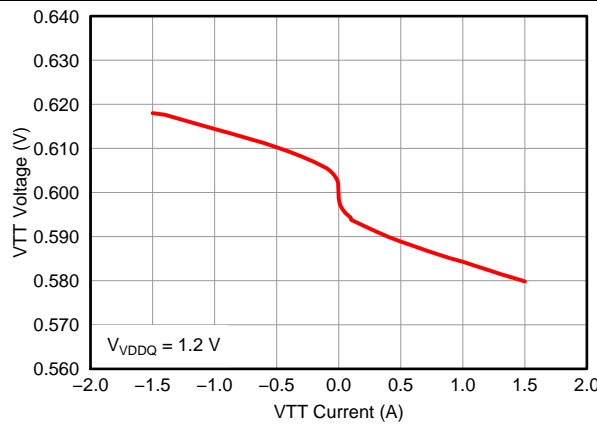

Figure 23. VTT Load Regulation

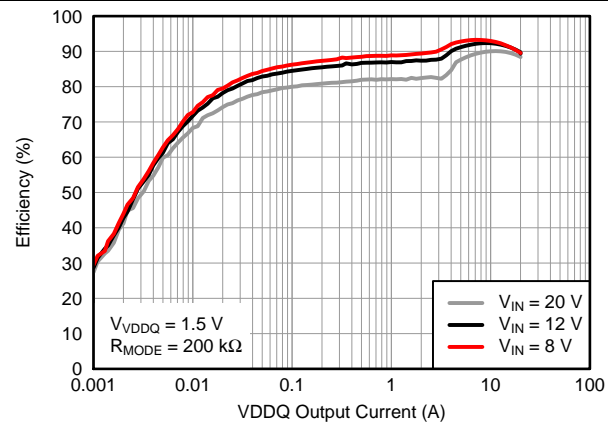

Figure 24. Efficiency

Typical Characteristics (continued)

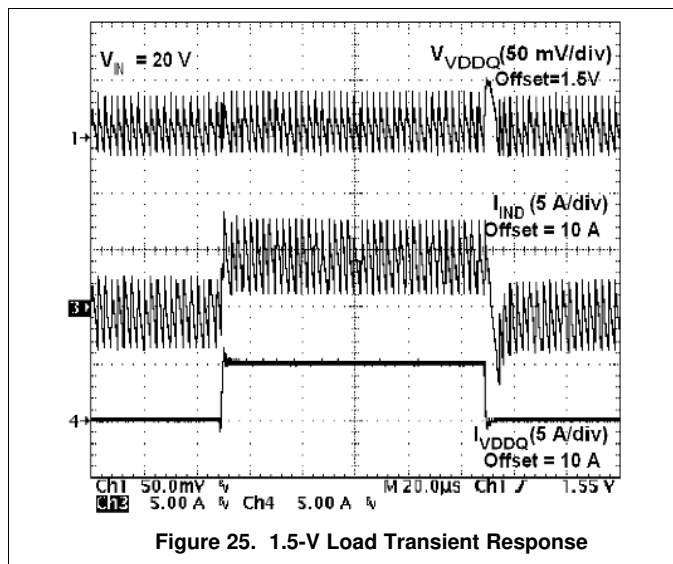

Figure 25. 1.5-V Load Transient Response

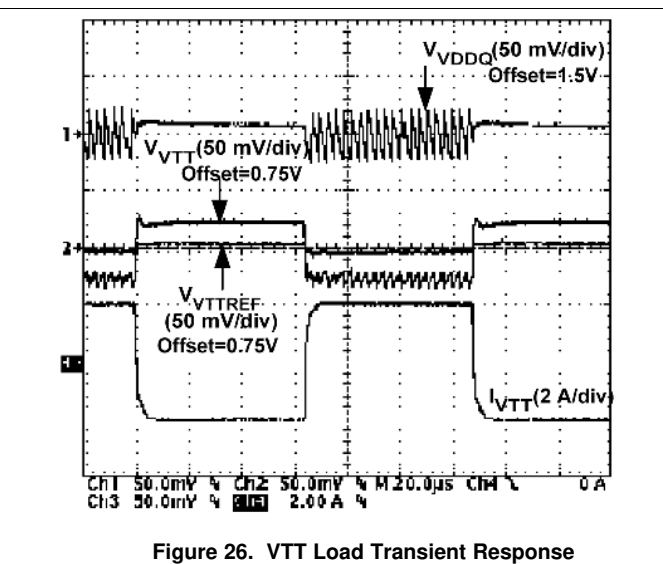

Figure 26. VTT Load Transient Response

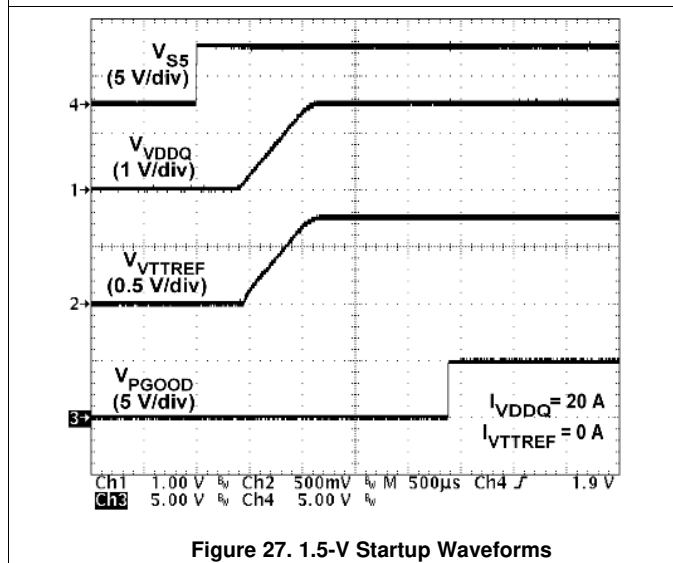

Figure 27. 1.5-V Startup Waveforms

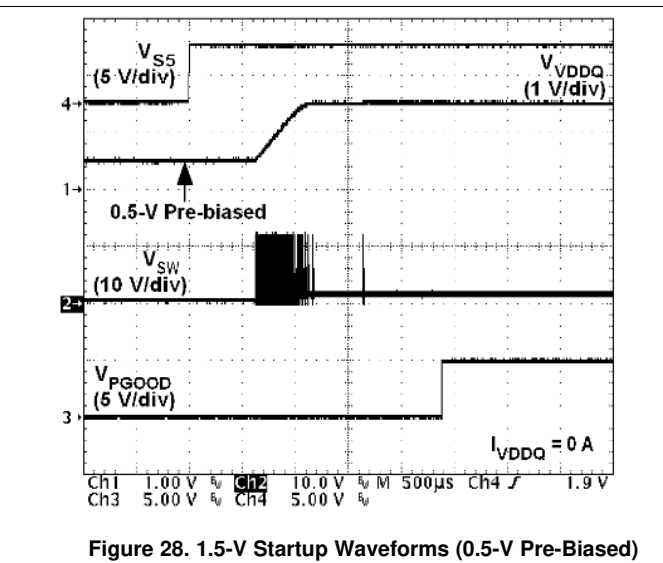

Figure 28. 1.5-V Startup Waveforms (0.5-V Pre-Biased)

Typical Characteristics (continued)

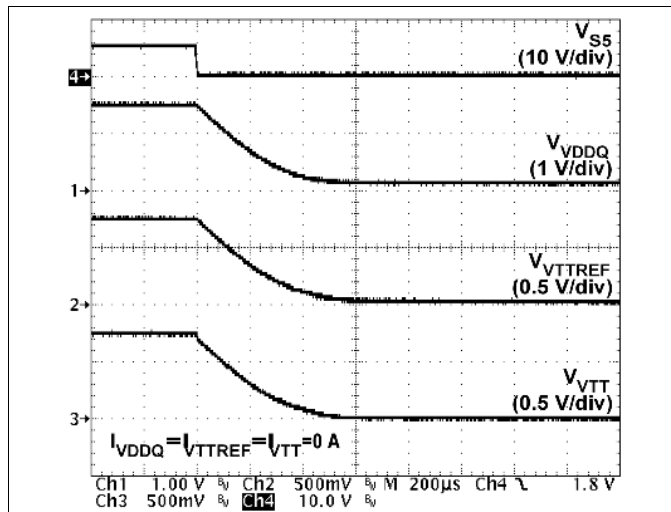

Figure 29. 1.5-V Soft-Stop Waveforms (Tracking Discharge)

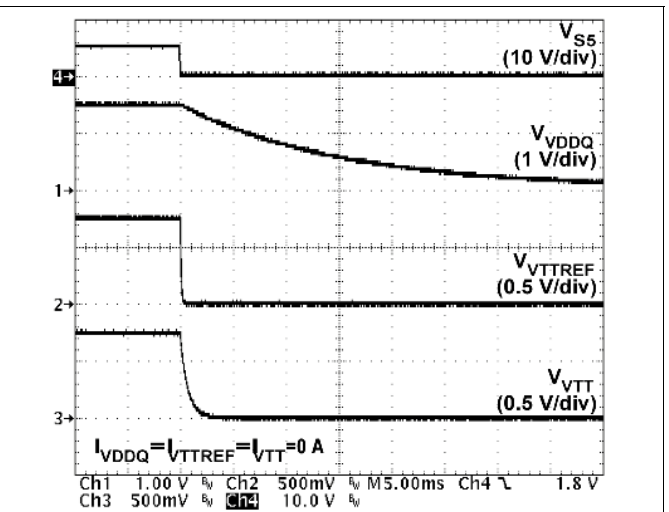

Figure 30. 1.5-V Soft-Stop Waveforms (Non-Tracking Discharge)

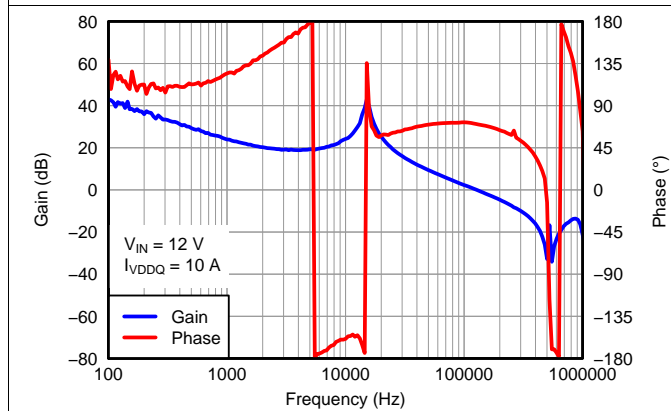

Figure 31. VDDQ Bode Plot

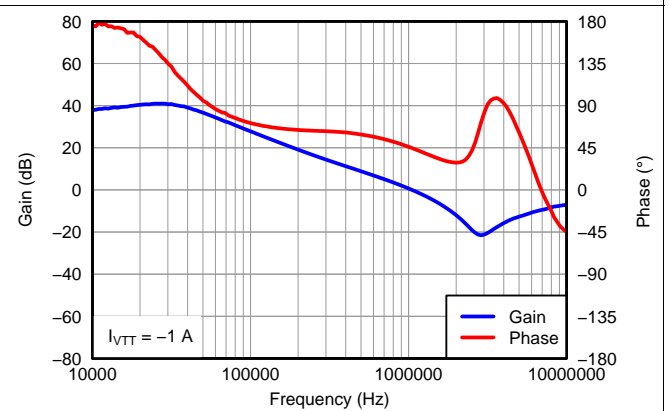

Figure 32. VTT Bode Plot (Sink)

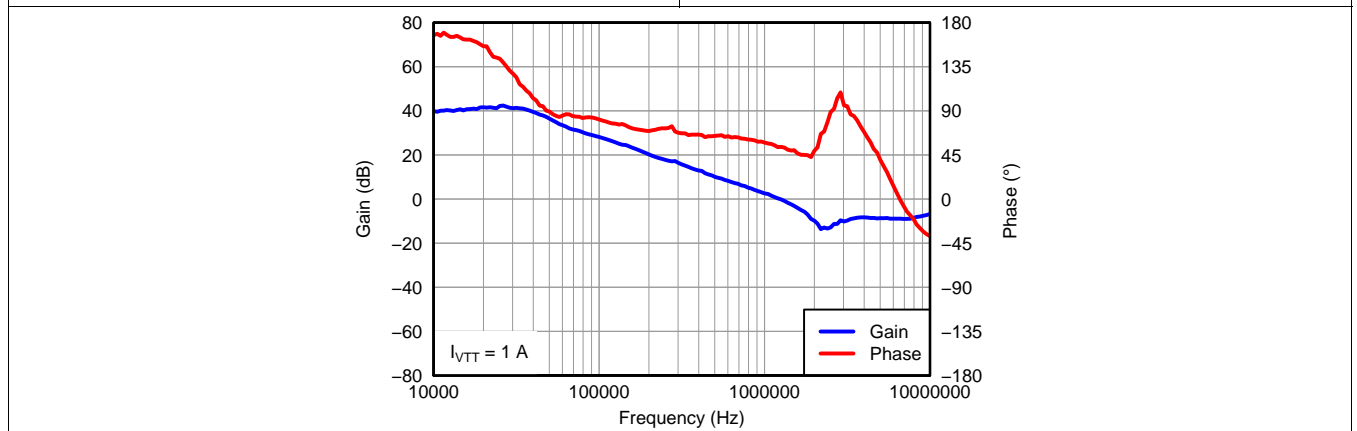
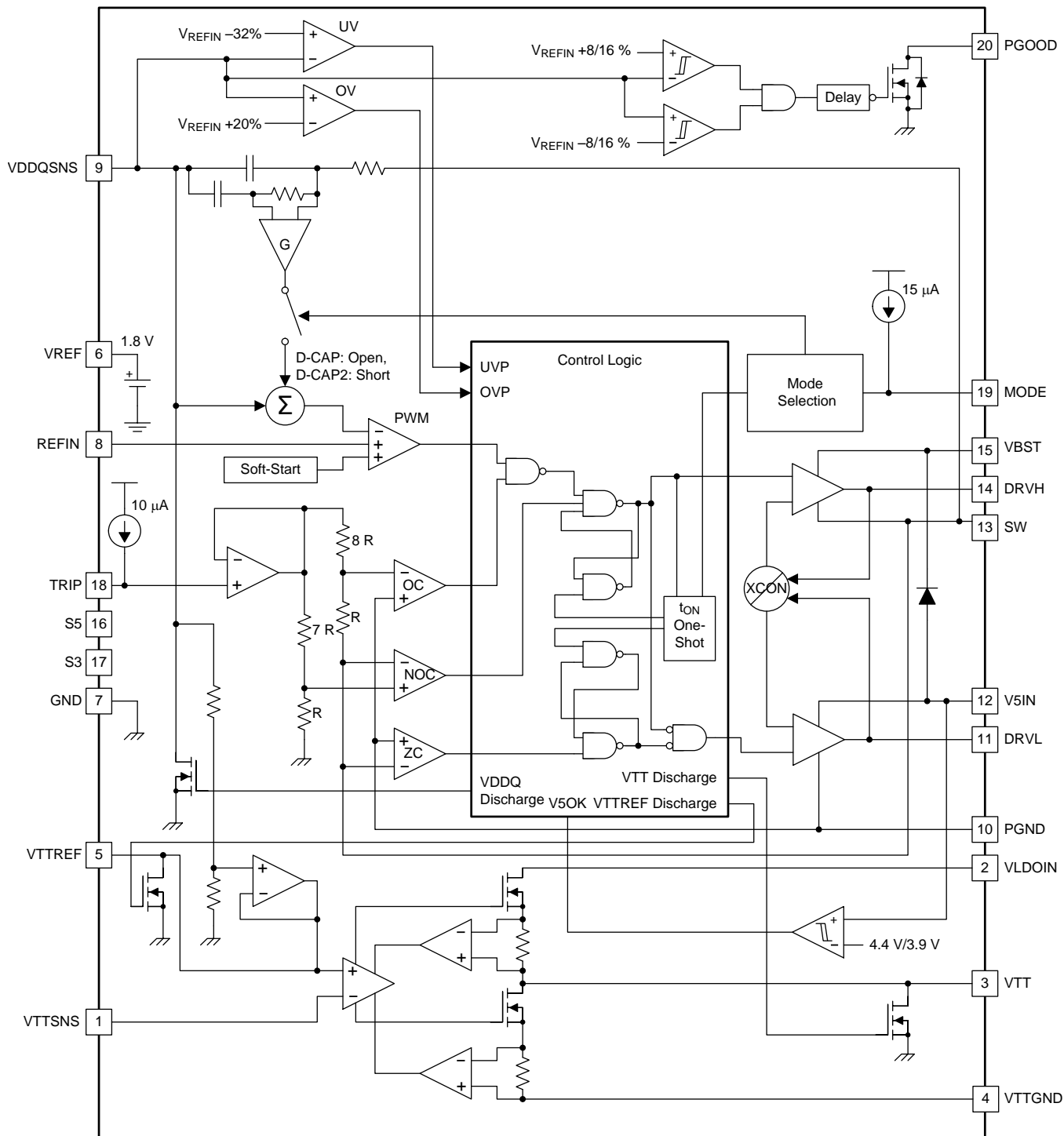

Figure 33. VTT Bode Plot (Source)

7 Detailed Description

7.1 Overview

7.2 Functional Block Diagram



Copyright © 2016, Texas Instruments Incorporated

7.3 Feature Description

7.3.1 VDDQ Switch Mode Power Supply Control

The TPS51916 device supports two SMPS control architectures, D-CAP™ mode and D-CAP2™ mode. Both control modes do not require complex external compensation networks and are suitable for designs with small external components counts. The D-CAP™ mode provides fast transient response with appropriate amount of equivalent series resistance (ESR) on the output capacitors. The D-CAP2™ mode is dedicated for a configuration with very low ESR output capacitors such as multi-layer ceramic capacitors (MLCC). For the both modes, an adaptive on-time control scheme is used to achieve pseudo-constant frequency. The TPS51916 device adjusts the on-time (t_{ON}) to be inversely proportional to the input voltage (V_{IN}) and proportional to the output voltage (V_{VDDQ}). This makes a switching frequency fairly constant over the variation of input voltage at the steady state condition. These control modes and switching frequencies are selected by the MODE pin described in [Table 2](#).

7.3.2 VREF and REFIN, VDDQ Output Voltage

The part provides a 1.8-V, $\pm 0.8\%$ accurate, voltage reference from VREF. This output has a 300- μ A (max) current capability to drive the REFIN input voltage through a voltage divider circuit. A capacitor with a value of 0.1- μ F or larger should be attached close to the VREF terminal.

The VDDQ switch-mode power supply (SMPS) output voltage is defined by REFIN voltage, within the range between 0.7 V and 1.8 V, programmed by the resistor-divider connected between VREF and GND. (See section.) A few nano farads of capacitance from REFIN to GND is recommended for stable operation.

7.3.3 Soft-Start and Powergood

Provide a voltage supply to VIN and V5IN before asserting S5 to high. TPS51916 device provides integrated VDDQ soft-start functions to suppress in-rush current at start-up. The soft-start is achieved by controlling internal reference voltage ramping up. [Figure 34](#) shows the start-up waveforms. The switching regulator waits for 400 μ s after S5 assertion. The MODE pin voltage is read in this period. A typical VDDQ ramp up duration is 700 μ s.

TPS51916 device has a powergood open-drain output that indicates the VDDQ voltage is within the target range. The target voltage window and transition delay times of the PGOOD comparator are $\pm 8\%$ (typ) and 1-ms delay for assertion (low to high), and $\pm 16\%$ (typ) and 330-ns delay for de-assertion (high to low) during running. The PGOOD start-up delay is 2.5 ms after S5 is asserted to high. Note that the time constant which is composed of the REFIN capacitor and a resistor divider needs to be short enough to reach the target value before PGOOD comparator enabled.

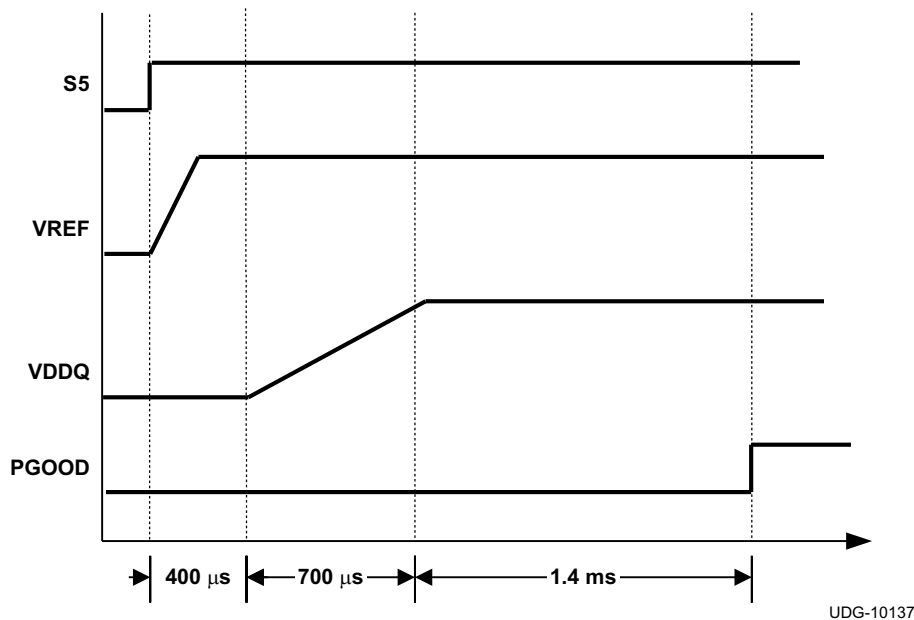

Figure 34. Typical Start-up Waveforms

Feature Description (continued)

7.3.4 Power State Control

The TPS51916 device has two input pins, S3 and S5, to provide simple control scheme of power state. All of VDDQ, VTTREF and VTT are turned on at S0 state (S3=S5=high). In S3 state (S3=low, S5=high), VDDQ and VTTREF voltages are kept on while VTT is turned off and left at high impedance state (high-Z). The VTT output floats and does not sink or source current in this state. In S4/S5 states (S3=S5=low), all of the three outputs are turned off and discharged to GND according to the discharge mode selected by MODE pin. Each state code represents as follow; S0 = full ON, S3 = suspend to RAM (STR), S4 = suspend to disk (STD), S5 = soft OFF. (See [Table 1](#))

Table 1. S3 or S5 Power State Control

STATE	S3	S5	VREF	VDDQ	VTTREF	VTT
S0	HI	HI	ON	ON	ON	ON
S3	LO	HI	ON	ON	ON	OFF(High-Z)
S4/S5	LO	LO	OFF	OFF(Discharge)	OFF(Discharge)	OFF(Discharge)

7.3.5 Discharge Control

In S4/S5 state, VDDQ, VTT, and VTTREF outputs are discharged based on the respective discharge mode selected above. The tracking discharge mode discharges VDDQ output through the internal VTT regulator transistors enabling quick discharge operation. The VTT output maintains tracking of the VTTREF voltage in this mode. (Please refer to [Figure 29](#)) After 4 ms of tracking discharge operation, the mode changes to non-tracking discharge. The VDDQ output must be connected to the VLDOIN pin in this mode. The non-tracking mode discharges the VDDQ and VTT pins using internal MOSFETs that are connected to corresponding output terminals. The non-tracking discharge is slow compared with the tracking discharge due to the lower current capability of these MOSFETs. (Please refer to [Figure 30](#))

7.3.6 VTT and VTTREF

The TPS51916 device integrates two high-performance, low-drop-out linear regulators, VTT and VTTREF, to provide complete DDR2, DDR3, DDR3L, and DDR4 power solutions. The VTTREF has a 10-mA sink/source current capability, and tracks $\frac{1}{2}$ of VDDQSNS with $\pm 1\%$ accuracy using an on-chip $\frac{1}{2}$ divider. A 0.22- μF (or larger) ceramic capacitor must be connected close to the VTTREF terminal to ensure stable operation. The VTT responds quickly to track VTTREF within ± 40 mV at all conditions, and the current capability is 2 A for both sink and source. A 10- μF (or larger) ceramic capacitor(s) need to be connected close to the VTT terminal for stable operation. To achieve tight regulation with minimum effect of wiring resistance, a remote sensing terminal, VTTSENS, should be connected to the positive node of VTT output capacitors as a separate trace from the high-current line to the VTT pin. (Refer to the [Layout](#) section for details.)

When VTT is not required in the design, following treatment is strongly recommended.

- Connect VLDOIN to VDDQ.
- Tie VTTSENS to VTT, and remove capacitors from VTT to float.
- Connect VTTGND to GND.
- Select MODE2, 3, 4 or 5 shown in [Table 2](#) (Select Non-tracking discharge mode).
- Maintain a 0.22- μF capacitor connected at VTTREF.
- Pull down S3 to GND with 1-k Ω resistance.

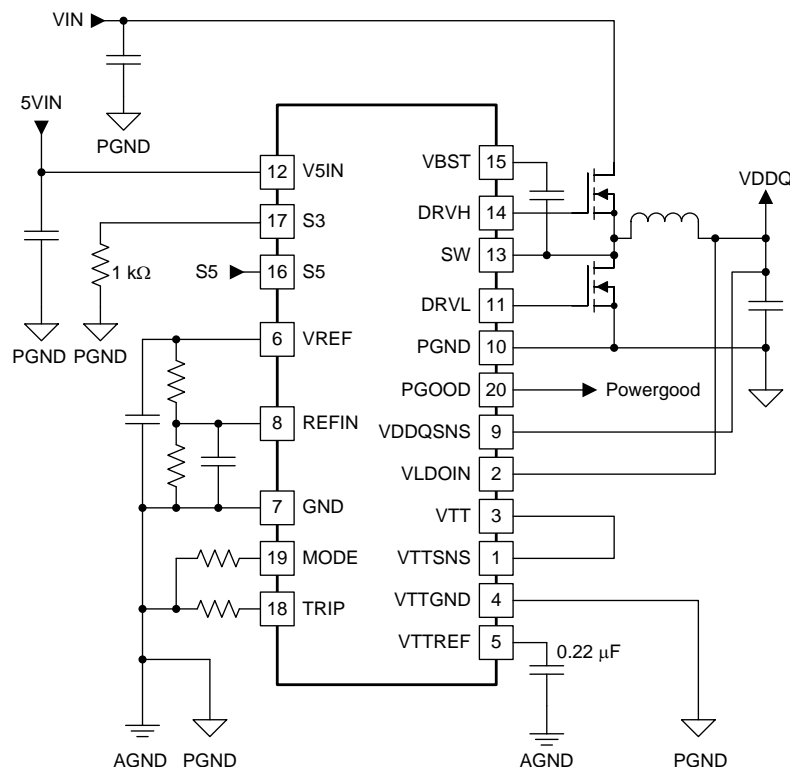

Copyright © 2016, Texas Instruments Incorporated

Figure 35. Application Circuit When VTT Is Not Required

7.3.7 VDDQ Overvoltage and Undervoltage Protection

The TPS51916 sets the overvoltage protection (OVP) when VDDQSNS voltage reaches a level 20% (typ) higher than the REFIN voltage. When an OV event is detected, the controller changes the output target voltage to 0 V. This usually turns off DRVH and forces DRVL to be on. When the inductor current begins to flow through the low-side MOSFET and reaches the negative OCL, DRVL is turned off and DRVH is turned on, for a minimum on-time.

After the minimum on-time expires, DRVH is turned off and DRVL is turned on again. This action minimizes the output node undershoot due to LC resonance. When the VDDQSNS reaches 0 V, the driver output is latched as DRVH off, DRVL on. VTTREF and VTT are turned off and discharged using the non-tracking discharge MOSFETs regardless of the tracking mode.

The undervoltage protection (UVP) latch is set when the VDDQSNS voltage remains lower than 68% (typ) of the REFIN voltage for 1 ms or longer. In this fault condition, the controller latches DRVH low and DRVL low and discharges the VDDQ, VTT and VTTREF outputs. UVP detection function is enabled after 1.2 ms of SMPS operation to ensure startup.

To release the OVP and UVP latches, toggle S5 or adjust the V5IN voltage down and up beyond the undervoltage lockout threshold.

7.3.8 VDDQ Out-of-Bound Operation

When the output voltage rises to 8% above the target value, the out-of-bound operation starts. During the out-of-bound condition, the controller operates in forced PWM-only mode. Turning on the low-side MOSFET beyond the zero inductor current quickly discharges the output capacitor. During this operation, the cycle-by-cycle negative overcurrent limit is also valid. Once the output voltage returns to within regulation range, the controller resumes to auto-skip mode.

7.3.9 VDDQ Overcurrent Protection

The VDDQ SMPS has cycle-by-cycle overcurrent limiting protection. The inductor current is monitored during the off-state using the low-side MOSFET $R_{DS(on)}$, and the controller maintains the off-state when the inductor current is larger than the overcurrent trip level. The current monitor circuit inputs are PGND and SW pins so that those should be properly connected to the source and drain terminals of low-side MOSFET. The overcurrent trip level, V_{OCTRIP} , is determined by Equation 1, where R_{TRIP} is the value of the resistor connected between the TRIP pin and GND, and I_{TRIP} is the current sourced from the TRIP pin. I_{TRIP} is 10 μ A typically at room temperature, and has 4700ppm/ $^{\circ}$ C temperature coefficient to compensate the temperature dependency of the low-side MOSFET $R_{DS(on)}$.

$$V_{OCTRIP} = R_{TRIP} \times \frac{I_{TRIP}}{8} \quad (1)$$

Because the comparison is done during the off-state, V_{OCTRIP} sets the valley level of the inductor current. The load current OCL level, I_{OCL} , can be calculated by considering the inductor ripple current as shown in Equation 2.

$$I_{OCL} = \left(\frac{V_{OCTRIP}}{R_{DS(on)}} \right) + \frac{I_{IND(ripple)}}{2} = \left(\frac{V_{OCTRIP}}{R_{DS(on)}} \right) + \frac{1}{2} \times \frac{V_{IN} - V_{OUT}}{L_X} \times \frac{V_{OUT}}{f_{SW} \times V_{IN}}$$

where

- $I_{IND(ripple)}$ is inductor ripple current (2)

In an overcurrent condition, the current to the load exceeds the current to the output capacitor, thus the output voltage tends to fall down. Eventually, it crosses the undervoltage protection threshold and shuts down.

7.3.10 VTT Overcurrent Protection

The LDO has an internally fixed constant overcurrent limiting of 3-A (typ) for both sink and source operation.

7.3.11 V5IN Undervoltage Lockout Protection

The TPS51916 has a 5-V supply undervoltage lockout protection (UVLO) threshold. When the V5IN voltage is lower than UVLO threshold voltage, typically 3.9 V, VDDQ, VTT and VTTREF are shut off. This is a non-latch protection.

7.3.12 Thermal Shutdown

The TPS51916 includes an internal temperature monitor. If the temperature exceeds the threshold value, 140 $^{\circ}$ C (typ), VDDQ, VTT and VTTREF are shut off. The state of VDDQ is open, and that of VTT and VTTREF are high impedance (high-Z) at thermal shutdown. The discharge functions of all outputs are disabled. This is a non-latch protection and the operation is restarted with soft-start sequence when the device temperature is reduced by 10 $^{\circ}$ C (typ).

7.4 Device Functional Modes

7.4.1 MODE Pin Configuration

The TPS51916 device reads the MODE pin voltage when the S5 signal is raised high and stores the status in a register. A 15- μ A current is sourced from the MODE pin during this time to read the voltage across the resistor connected between the pin and GND. Table 2 shows resistor values, corresponding control mode, switching frequency and discharge mode configurations.

Table 2. MODE Selection

MODE NO.	RESISTANCE BETWEEN MODE AND GND (k Ω)	CONTROL MODE	SWITCHING FREQUENCY (kHz)	DISCHARGE MODE
7	200	D-CAP™	400	Tracking
6	100		300	
5	68		300	Non-tracking
4	47		400	
3	33	D-CAP2™	500	Non-tracking
2	22		670	
1	12		670	Tracking
0	1		500	

7.4.2 D-CAP™ Mode

Figure 36 shows a simplified model of D-CAP™ mode architecture.

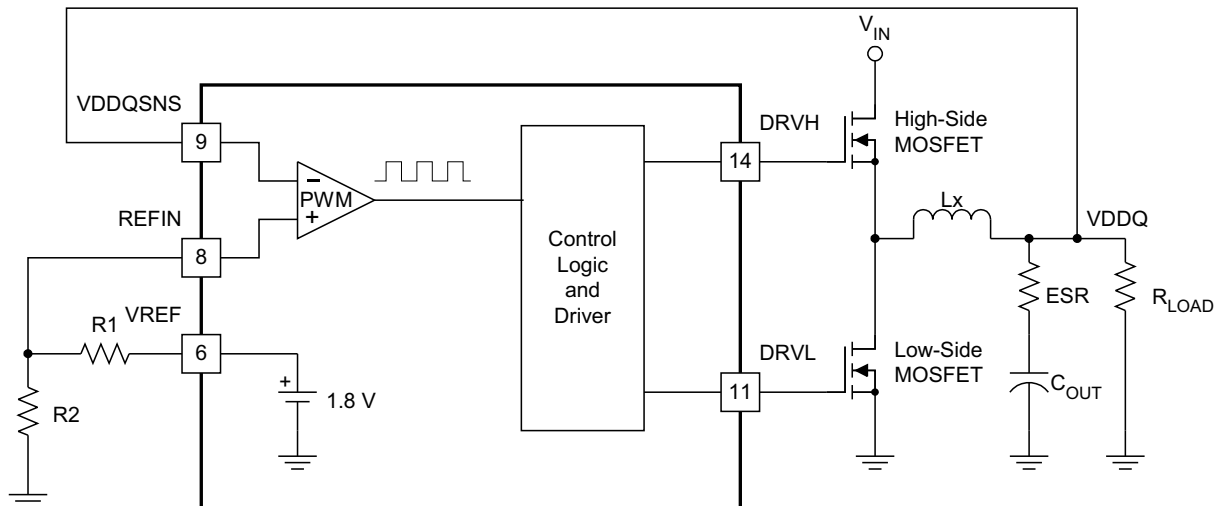

UDG-10136

Figure 36. Simplified D-CAP™ Model

The VDDQSNS voltage is compared with REFIN voltage. The PWM comparator creates a set signal to turn on the high-side MOSFET. The gain and speed of the comparator is high enough to maintain the voltage at the beginning of each on-cycle (or the end of each off-cycle) to be substantially constant. The DC output voltage monitored at VDDQ may have line regulation due to ripple amplitude that slightly increases as the input voltage increase. The D-CAP™ mode offers flexibility on output inductance and capacitance selections with ease-of-use without complex feedback loop calculation and external components. However, it does require a sufficient level of ESR that represents inductor current information for stable operation and good jitter performance. Organic semiconductor capacitor(s) or specialty polymer capacitor(s) are recommended.

The requirement for loop stability is simple and is described in Equation 3. The 0-dB frequency, f_0 defined in Equation 3, is recommended to be lower than 1/3 of the switching frequency to secure proper phase margin.

$$f_0 = \frac{1}{2\pi \times \text{ESR} \times C_{\text{OUT}}} \leq \frac{f_{\text{SW}}}{3}$$

where

- ESR is the effective series resistance of the output capacitor
- C_{OUT} is the capacitance of the output capacitor
- f_{sw} is switching frequency

(3)

Jitter is another attribute caused by signal-to-noise ratio of the feedback signal. One of the major factors that determine jitter performance in D-CAP™ mode is the down-slope angle of the VDDQSNS ripple voltage. Figure 37 shows, in the same noise condition, that jitter is improved by making the slope angle larger.

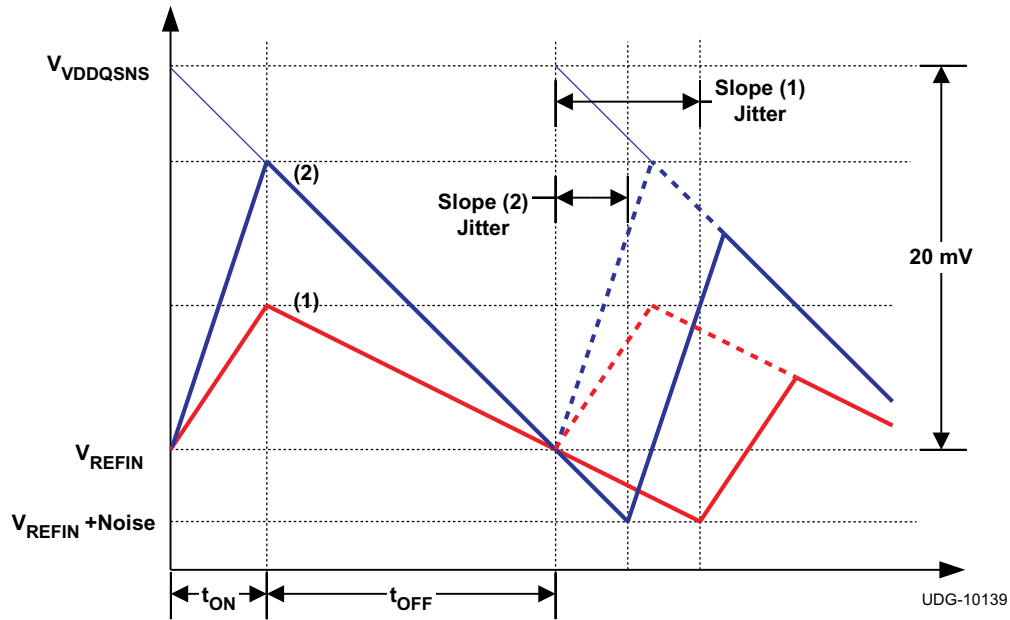

Figure 37. Ripple Voltage Slope and Jitter Performance

For a good jitter performance, use the recommended down slope of approximately 20 mV per switching period as shown in Figure 37 and Equation 4.

$$\frac{V_{\text{OUT}} \times \text{ESR}}{f_{\text{SW}} \times L_X} \geq 20\text{mV}$$

where

- V_{OUT} is the VDDQ output voltage
- L_X is the inductance

(4)

7.5 D-CAP2™ Mode Operation

Figure 38 shows simplified model of D-CAP2™ architecture.

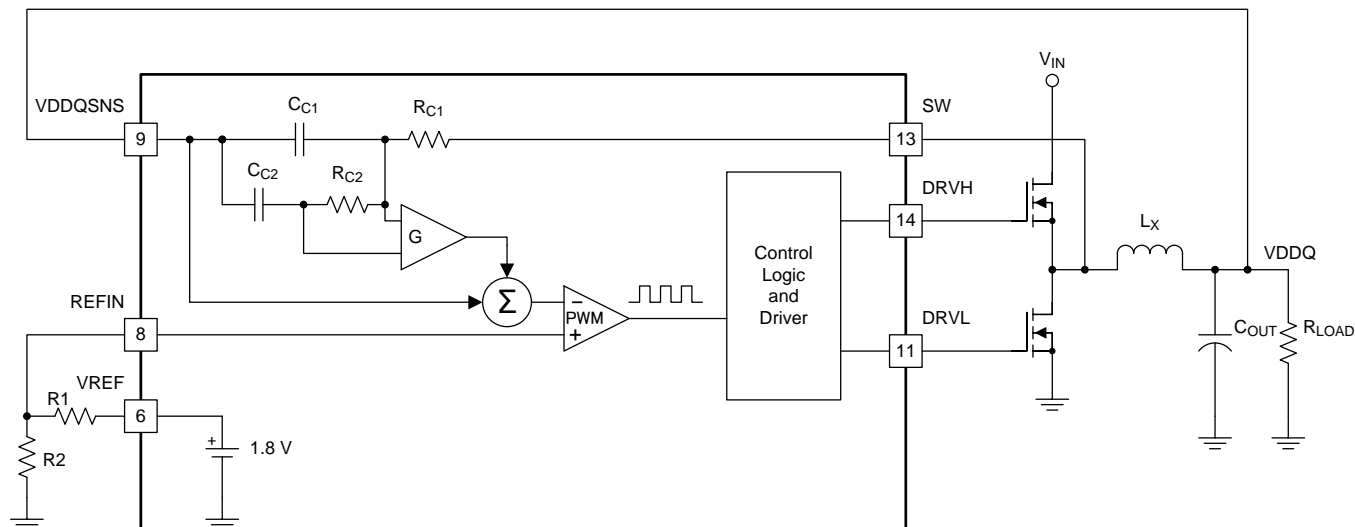

Figure 38. Simplified Modulator Using D-CAP2™ Mode

The D-CAP2™ mode in the TPS51916 device includes an internal feedback network enabling the use of very low ESR output capacitor(s) such as multi-layer ceramic capacitors. The role of the internal network is to sense the ripple component of the inductor current information and combine it with voltage feedback signal. Using $R_{C1}=R_{C2}\equiv R_C$ and $C_{C1}=C_{C2}\equiv C_C$, 0-dB frequency of the D-CAP2™ mode is given by Equation 5. It is recommended that the 0-dB frequency (f_0) be lower than 1/3 of the switching frequency to secure the proper phase margin

$$f_0 = \frac{R_C \times C_C}{2\pi \times G \times L_X \times C_{OUT}} \leq \frac{f_{SW}}{3}$$

where

- G is gain of the amplifier which amplifies the ripple current information generated by the compensation circuit (5)

The typical G value is 0.25, and typical $R_C C_C$ time constant values for 500 kHz and 670 kHz operation are 23 μ s and 14.6 μ s, respectively.

For example, when $f_{SW}=500$ kHz and $L_X=1$ μ H, C_{OUT} should be larger than 88 μ F.

When selecting the capacitor, pay attention to its characteristics. For MLCC use X5R or better dielectric and consider the derating of the capacitance by both DC bias and AC bias. When derating by DC bias and AC bias are 80% and 50%, respectively, the effective derating is 40% because $0.8 \times 0.5 = 0.4$. The capacitance of specialty polymer capacitors may change depending on the operating frequency. Consult capacitor manufacturers for specific characteristics.

8 Application and Implementation

NOTE

Information in the following applications sections is not part of the TI component specification, and TI does not warrant its accuracy or completeness. TI's customers are responsible for determining suitability of components for their purposes. Customers should validate and test their design implementation to confirm system functionality.

8.1 Application Information

8.1.1 DDR3, D-CAP™ 400-kHz Application with Tracking Discharge

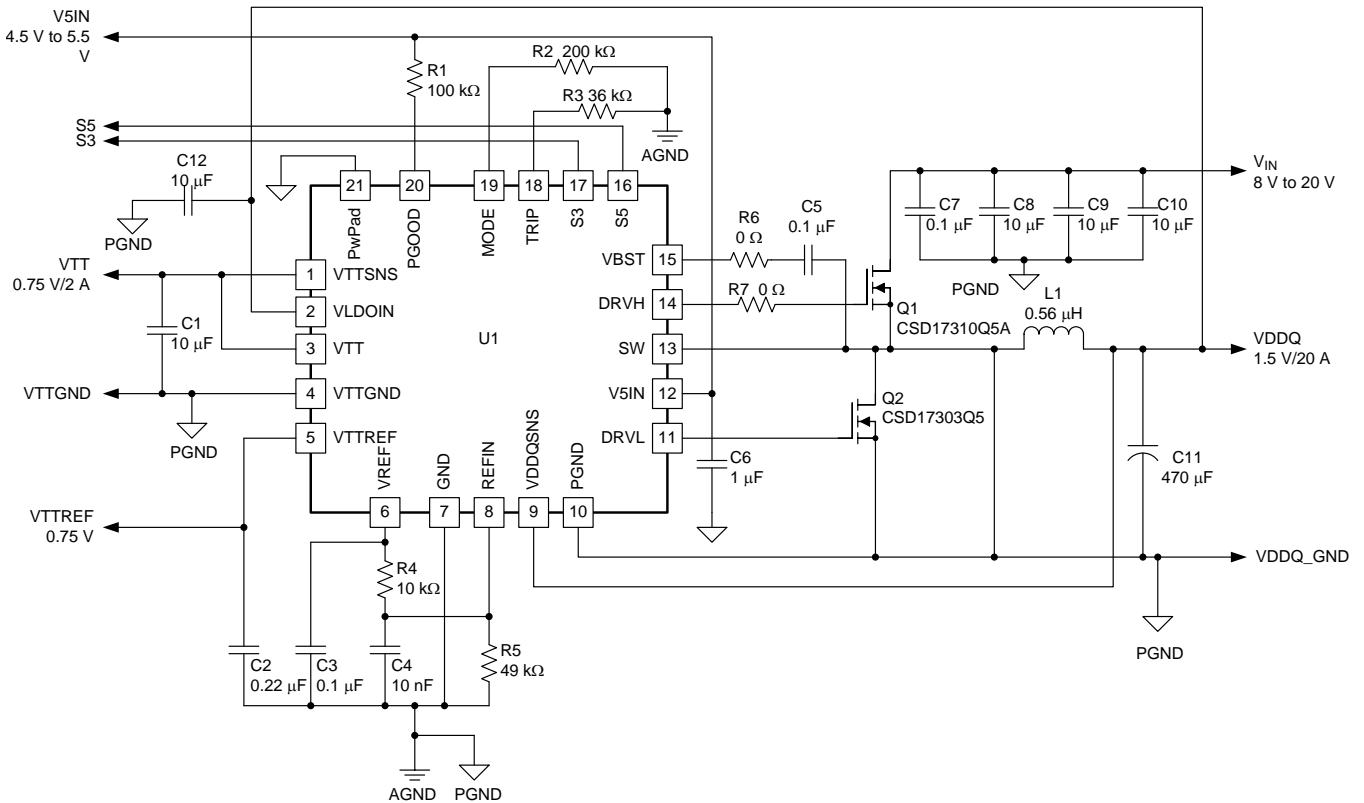

Copyright © 2016, Texas Instruments Incorporated

Figure 39. DDR3, D-CAP™ 400-kHz Application Circuit, Tracking Discharge

8.1.1.1 Design Requirements

Table 3. Design Requirements

PARAMETER		TEST CONDITIONS	MIN	TYP	MAX	UNIT
V_{IN}	Input voltage		8	12	20	V
V_{V5IN}	V5IN voltage		4.5	5	5.5	V
V_{VDDQ}	VDDQ output voltage			1.5		V
I_{VDDQ}	VDDQ output current		0		20	A
V_{VTT}	VTT output voltage			0.75		V
I_{VTT}	VTT output current	DDR3 mode , $V_{VTT} = 0.75$ V	-2		2	A
f_{SW}	Switching frequency	DCAP mode		400		kHz

8.1.1.2 Detailed Design Procedure

The external components selection is simple in D-CAP™ mode.

8.1.1.2.1 1. Determine the value of R1 AND R2

The output voltage is determined by the value of the voltage-divider resistor, R1 and R2 as shown in [Figure 36](#). R1 is connected between VREF and REFIN pins, and R2 is connected between the REFIN pin and GND. Setting R1 as 10-kΩ is a good starting point. Determine R2 using [Equation 6](#).

$$R2 = \frac{R1}{\left(\frac{1.8}{V_{OUT} - \left(\frac{I_{IND(ripple)} \times ESR}{2} \right)} \right) - 1} \quad (6)$$

8.1.1.2.2 2. Choose the inductor

The inductance value should be determined to yield a ripple current of approximately ¼ to ½ of maximum output current. Larger ripple current increases output ripple voltage and improves the signal-to-noise ratio and helps stable operation.

$$L_X = \frac{1}{I_{IND(ripple)} \times f_{SW}} \times \frac{(V_{IN(max)} - V_{OUT}) \times V_{OUT}}{V_{IN(max)}} = \frac{3}{I_{O(max)} \times f_{SW}} \times \frac{(V_{IN(max)} - V_{OUT}) \times V_{OUT}}{V_{IN(max)}} \quad (7)$$

The inductor needs a low direct current resistance (DCR) to achieve good efficiency, as well as enough room above peak inductor current before saturation. The peak inductor current can be estimated in [Equation 8](#).

$$I_{IND(peak)} = \frac{R_{TRIP} \times I_{TRIP}}{8 \times R_{DS(on)}} + \frac{1}{L \times f_{SW}} \times \frac{(V_{IN(max)} - V_{OUT}) \times V_{OUT}}{V_{IN(max)}} \quad (8)$$

8.1.1.2.3 3. Choose the OCL setting resistance, R_{TRIP}

Combining [Equation 1](#) and [Equation 2](#), R_{TRIP} can be obtained using [Equation 9](#).

$$R_{TRIP} = \frac{8 \times \left(I_{OCL} - \left(\frac{(V_{IN} - V_{OUT})}{(2 \times L_X)} \right) \times \frac{V_{OUT}}{(f_{SW} \times V_{IN})} \right) \times R_{DS(on)}}{I_{TRIP}} \quad (9)$$

8.1.1.2.4 Choose the output capacitors

Organic semiconductor capacitor(s) or specialty polymer capacitor(s) are recommended. Determine ESR to meet small signal stability and recommended ripple voltage. A quick reference is shown in [Equation 10](#) and [Equation 11](#).

$$\frac{1}{2\pi \times ESR \times C_{OUT}} \leq \frac{f_{SW}}{3} \quad (10)$$

$$\frac{V_{OUT} \times ESR}{f_{SW} \times L_X} \geq 20\text{mV} \quad (11)$$

Table 4. DDR3, D-CAP™ 400-kHz Application Circuit, List of Materials

REFERENCE DESIGNATOR	QTY	SPECIFICATION	MANUFACTURE	PART NUMBER
C8, C9, C10	3	10 μ F, 25 V	Taiyo Yuden	TMK325BJ106MM
C11	1	470 μ F, 2 V, 6 m Ω	Panasonic	EEFSE0D471R
L1	1	0.56 μ H, 21 A, 1.56 m Ω	Panasonic	ETQP4LR56WFC
Q1	1	30 V, 21 A, 4.5 m Ω	Texas Instruments	CSD17310Q5A
Q2	1	30 V, 32 A, 2 m Ω	Texas Instruments	CSD17303Q5

8.1.1.3 Application Curves

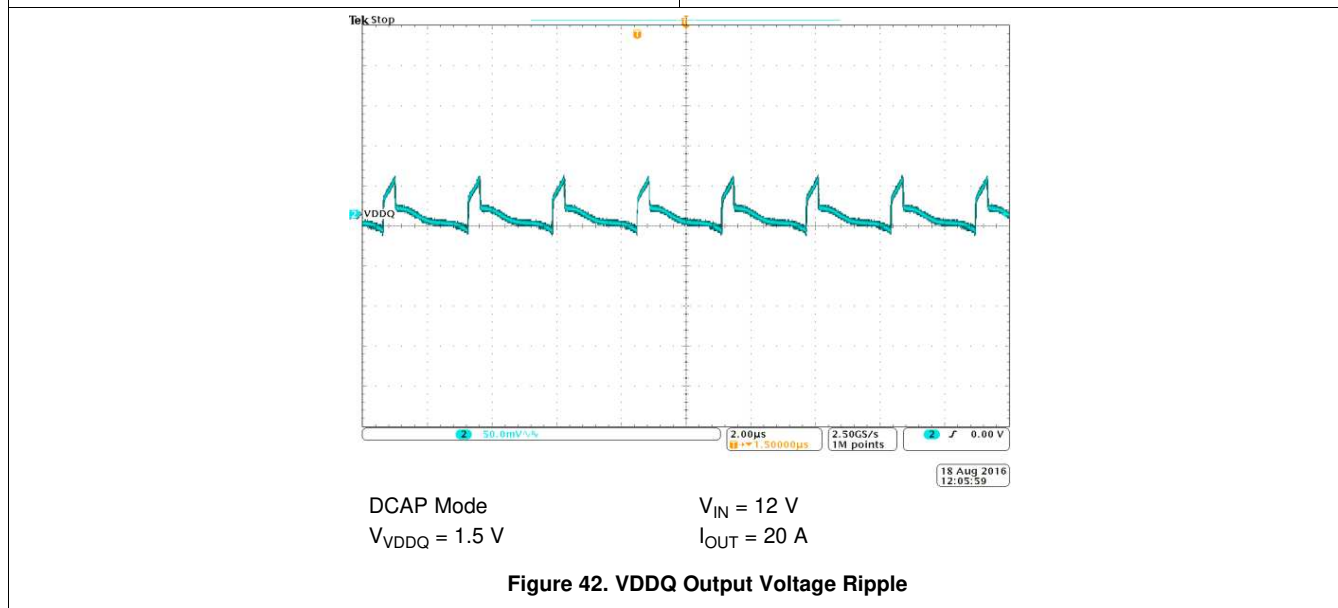
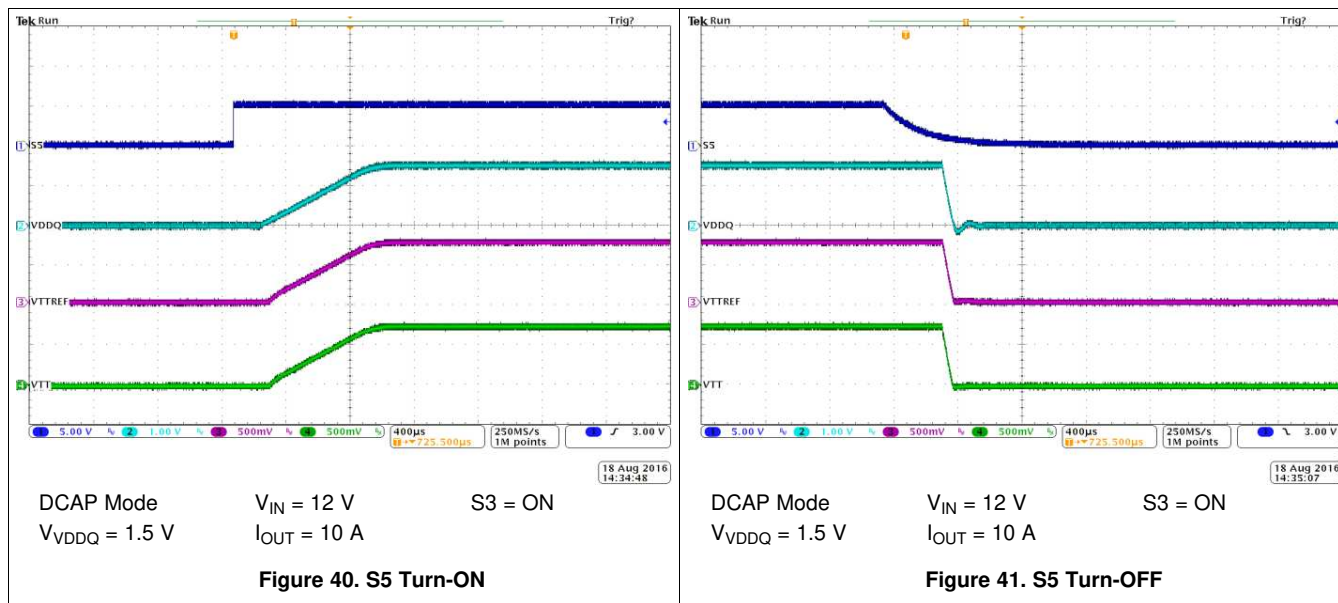

8.1.2 DDR3, DCAP-2 500-kHz Application, with Tracking Discharge

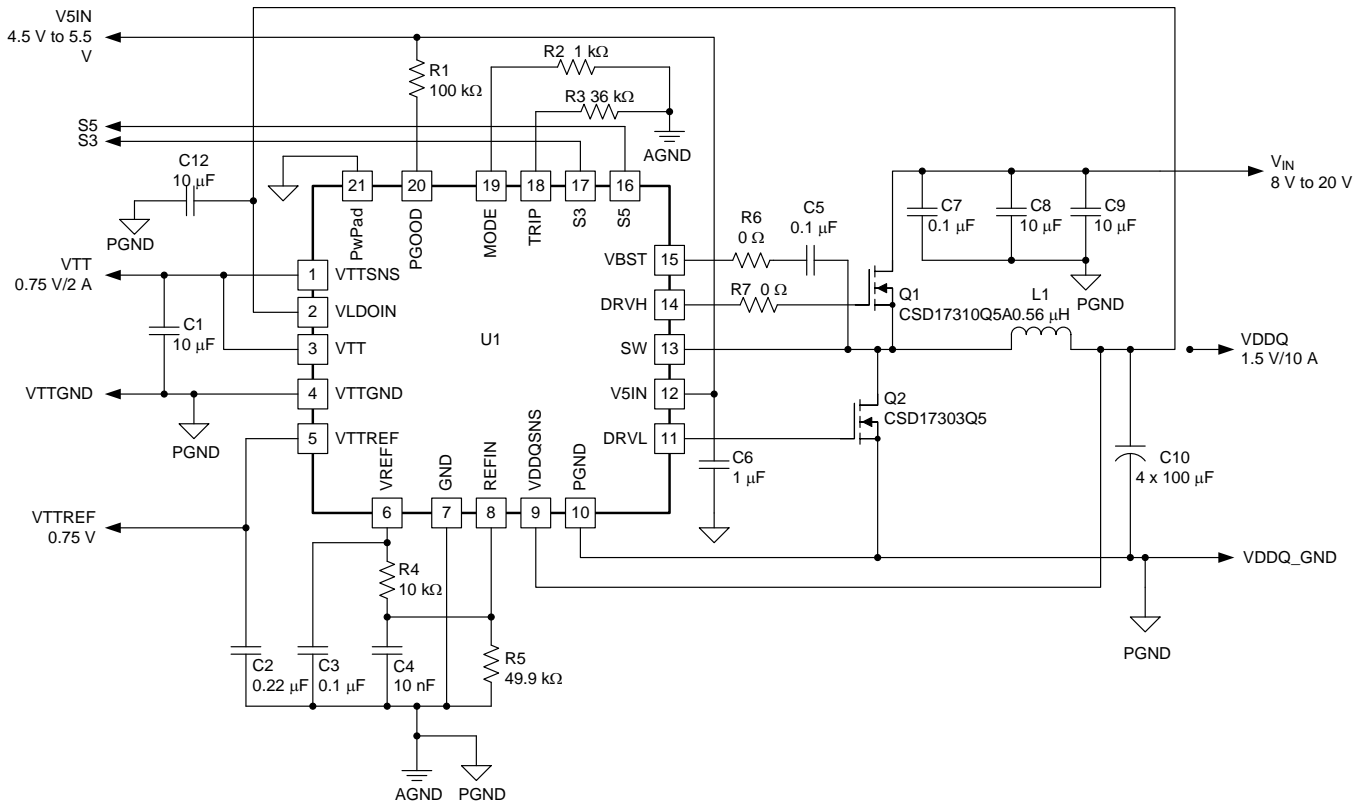

Copyright © 2016, Texas Instruments Incorporated

Figure 43. DDR3, DCAP-2 500-kHz Application Circuit, Tracking Discharge

Table 5. DDR3, DCAP-2 500-kHz Application Circuit, List of Materials

REFERENCE DESIGNATOR	QTY	SPECIFICATION	MANUFACTURE	PART NUMBER
C8, C9	2	10 μF, 25 V	Taiyo Yuden	TMK325BJ106MM
C10	4	100 μF, 6.3 V	Murata	GRM32ER60J107ME20L
L1	1	0.56 μH, 21 A, 1.56 mΩ	Panasonic	ETQP4LR56WFC
Q1	1	30 V, 21 A, 4.5 mΩ	Texas Instruments	CSD17310Q5A
Q2	1	30 V, 32 A, 2 mΩ	Texas Instruments	CSD17303Q5

8.1.2.1 Design Requirements

Table 6. Design Requirements

PARAMETER		TEST CONDITIONS	MIN	TYP	MAX	UNIT
V _{IN}	Input voltage		8	12	20	V
V _{V5IN}	V5IN voltage		4.5	5	5.5	V
V _{VDDQ}	VDDQ output voltage			1.5		V
I _{VDDQ}	VDDQ output current		0		20	A
V _{VTT}	VTT output voltage			0.75		V
I _{VTT}	VTT output current	DDR3 mode , V _{VTT} = 0.75 V	-2		2	A
f _{SW}	Switching frequency	DCAP2 mode		500		kHz

8.1.2.2 Detailed Design Procedure

The design procedure for this design is very similar to the design procedure for the design described in the previous section (see [DDR3, D-CAP™ 400-kHz Application with Tracking Discharge](#)). The key differences in the design procedure is described here.

8.1.2.2.1 Select Mode and Switching Frequency

Select a value of 1 kΩ for the mode resistor to set the controller at DCAP2 mode with a switching frequency of 500-kHz.

8.1.2.2.2 Determine output capacitance

Determine output capacitance to meet small signal stability as shown in [Equation 12](#).

$$\frac{R_C \times C_C}{2\pi \times G \times L_X \times C_{OUT}} \leq \frac{f_{SW}}{3}$$

where

- $R_C \times C_C$ time constant is 23 μs for 500 kHz operation (or 14.6 μs for 670 kHz operation)
- $G = 0.25$

(12)

8.1.2.3 Application Curves

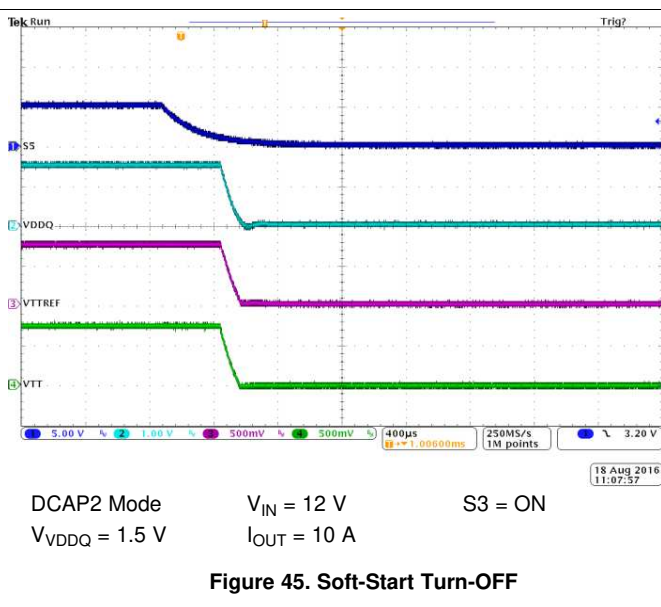
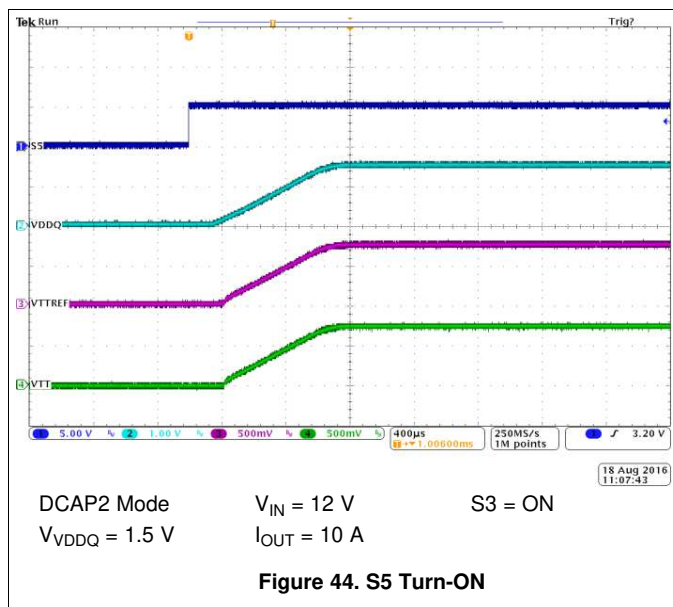

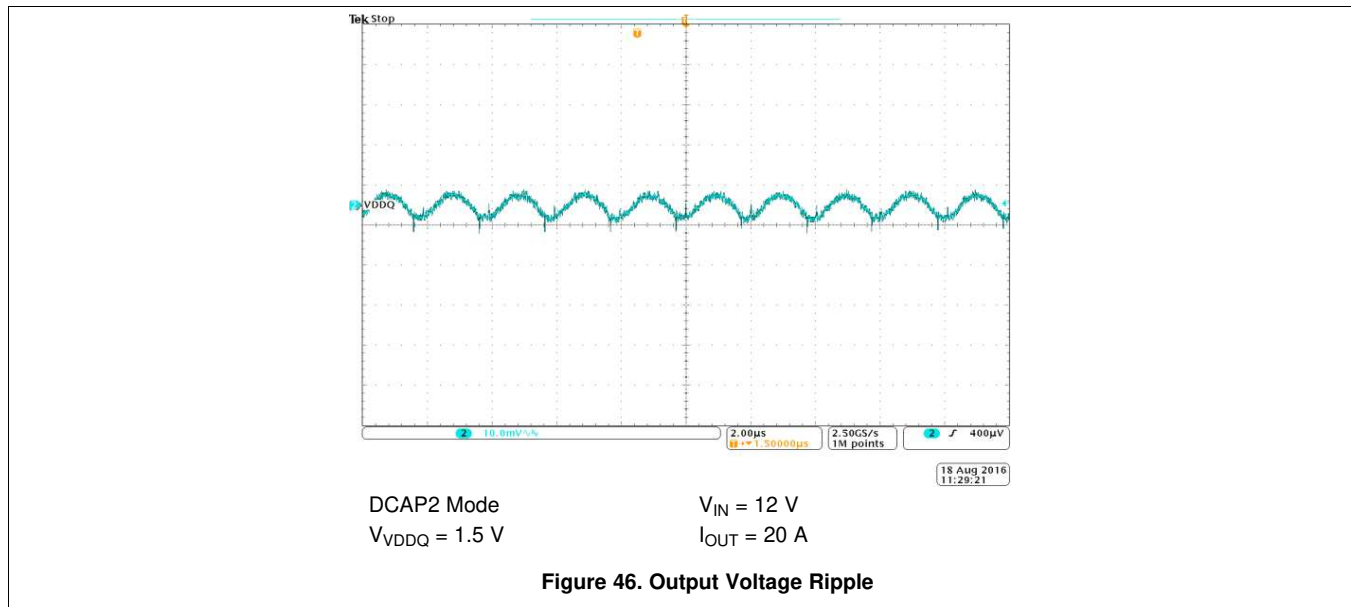

9 Power Supply Recommendations

The device is designed to operate from an input voltage supply between 3 V and 28 V. There are input voltage and switch node voltage limitations from the MOSFET. A separate 5-V power supply is required for the internal circuits and MOSFET gate drivers of the device.

10 Layout

10.1 Layout Guidelines

Certain issues must be considered before designing a layout using the TPS51916 device .

- V_{IN} capacitor(s), V_{OUT} capacitor(s) and MOSFETs are the power components and should be placed on one side of the PCB (solder side). Other small signal components should be placed on another side (component side). At least one inner system GND plane should be inserted, in order to shield and isolate the small signal traces from noisy power lines.
- All sensitive analog traces and components such as V_{DDQSNS} , V_{TTSNS} , $MODE$, $REFIN$, V_{REF} and $TRIP$ should be placed away from high-voltage switching nodes such as SW , $DRVL$, $DRVH$ or $VBST$ to avoid coupling. Use internal layer(s) as system GND plane(s) and shield feedback trace from power traces and components.
- The DC/DC converter has several high-current loops. The area of these loops should be minimized in order to suppress generating switching noise.
 - The most important loop to minimize the area of is the path from the V_{IN} capacitor(s) through the high and low-side MOSFETs, and back to the negative node of the V_{IN} capacitor(s). Connect the negative node of the V_{IN} capacitor(s) and the source of the low-side MOSFET as close as possible. (Refer to loop #1 of)
 - The second important loop is the path from the low-side MOSFET through inductor and V_{OUT} capacitor(s), and back to source of the low-side MOSFET. Connect the source of the low-side MOSFET and negative node of V_{OUT} capacitor(s) as close as possible. (Refer to loop #2 of)
 - The third important loop is of gate driving system for the low-side MOSFET. To turn on the low-side MOSFET, high current flows from V_{5IN} capacitor through gate driver and the low-side MOSFET, and back to negative node of the capacitor. To turn off the low-side MOSFET, high current flows from gate of the low-side MOSFET through the gate driver and PGND pin, and back to source of the low-side MOSFET. Connect negative node of V_{5IN} capacitor, source of the low-side MOSFET and PGND pin as close as possible. (Refer to loop #3 of [Figure 47](#))

Layout Guidelines (continued)

- Connect negative nodes of the VTTREF output capacitor, VREF capacitor and REFIN capacitor and bottom-side resistance of VREF voltage-divider to GND pin as close as possible. The negative node of the VTT output capacitor(s), VTTGND, GND and PGND pins should be connected to system GND plane near the device as shown in [Figure 48](#).
- Because the TPS51916 device controls output voltage referring to voltage across VOUT capacitor, VDDQSNS should be connected to the positive node of VOUT capacitor using different trace from that for VLDOIN. Remember that this sensing potential is the reference voltage of VTTREF. Avoid any noise generative lines. GND pin refers to the negative node of VOUT capacitor.
- Connect the overcurrent setting resistor from TRIP pin to GND pin and make the connections as close as possible to the device to avoid coupling from a high-voltage switching node.
- Connect the frequency and mode setting resistor from MODE pin to GND pin ground, and make the connections as close as possible to the device to avoid coupling from a high-voltage switching node.
- Connections from gate drivers to the respective gate of the high-side or the low-side MOSFET should be as short as possible to reduce stray inductance. Use 0.65 mm (25 mils) or wider trace and via(s) of at least 0.5 mm (20 mils) diameter along this trace.
- The PCB trace defined as SW node, which connects to the source of the high-side MOSFET, the drain of the low-side MOSFET and the high-voltage side of the inductor, should be as short and wide as possible.
- VLDOIN should be connected to VOUT with short and wide traces. An input bypass capacitor should be placed as close as possible to the pin with short and wide connections. The negative node of the capacitor should be connected to system GND plane.
- The output capacitor for VTT should be placed close to the pins with a short and wide connection in order to avoid additional ESR and/or ESL of the trace.
- VTTSENS should be connected to the positive node of the VTT output capacitor(s) using a separate trace from the high-current power line. When remote sensing is required attach the output capacitor(s) at that point. Also, it is recommended to minimize any additional ESR and/or ESL of ground trace between GND pin and the output capacitor(s).
- Consider adding a low pass filter (LPF) at VTTSENS in case the ESR of the VTT output capacitor(s) is larger than 2 mΩ.
- In order to effectively remove heat from the package, prepare a thermal land and solder to the package thermal pad. Wide trace of the component-side copper, connected to this thermal land, helps heat spreading. Numerous vias with a 0.3-mm diameter connected from the thermal land to the internal/solder-side ground plane(s) should be used to help dissipation. The thermal land can be connected to either AGND or PGND but is recommended to be connected to PGND, the system GND plane(s), which has better heat radiation.

Layout Guidelines (continued)

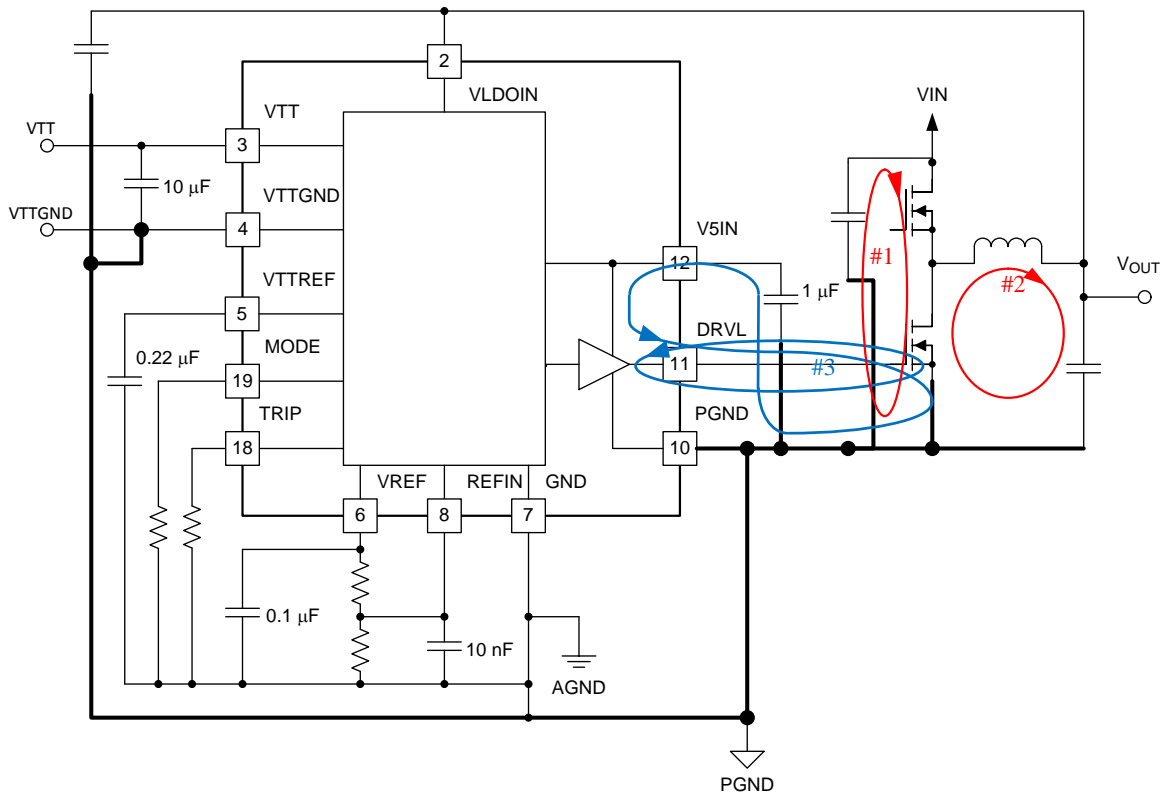

Figure 47. DC/DC Converter Ground System

10.2 Layout Example

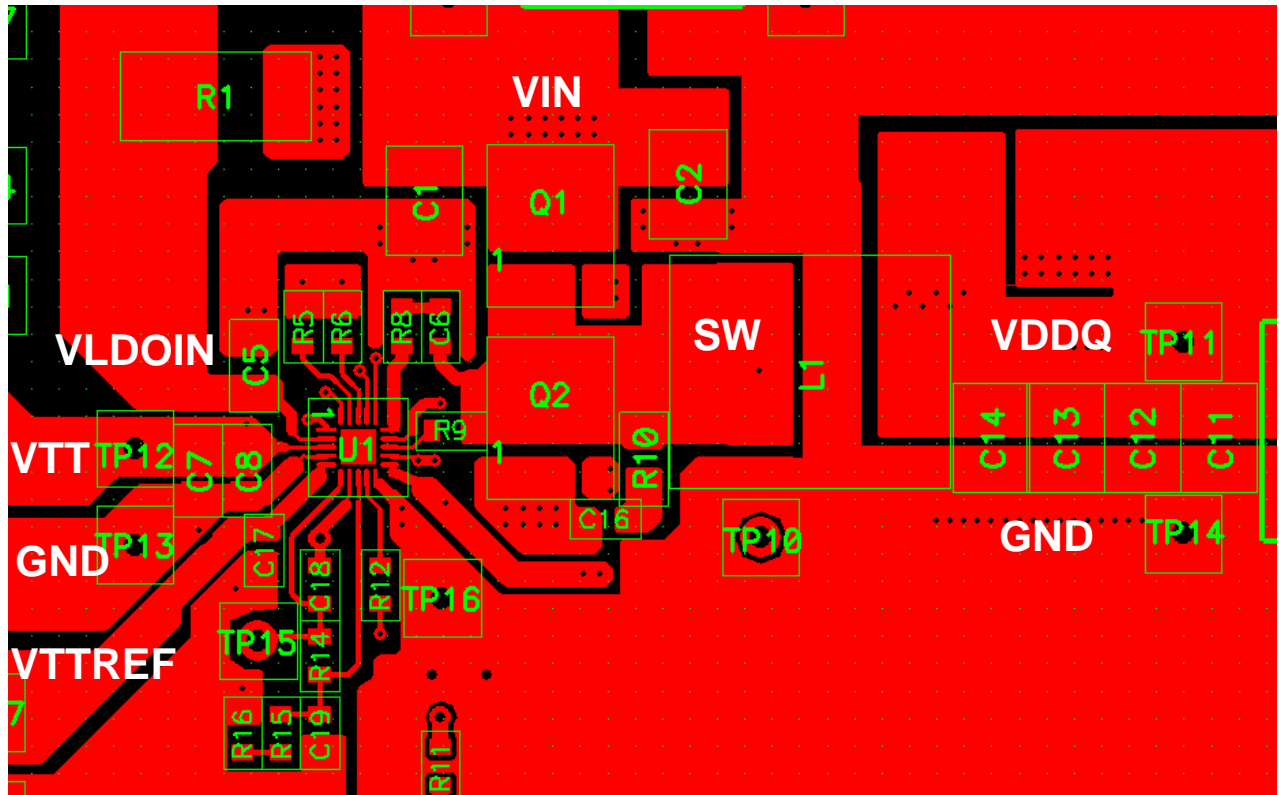

Figure 48. Layout Example

11 Device and Documentation Support

11.1 Receiving Notification of Documentation Updates

To receive notification of documentation updates, navigate to the device product folder on ti.com. In the upper right corner, click on *Alert me* to register and receive a weekly digest of any product information that has changed. For change details, review the revision history included in any revised document.

11.2 Community Resources

The following links connect to TI community resources. Linked contents are provided "AS IS" by the respective contributors. They do not constitute TI specifications and do not necessarily reflect TI's views; see TI's [Terms of Use](#).

TI E2E™ Online Community *TI's Engineer-to-Engineer (E2E) Community*. Created to foster collaboration among engineers. At e2e.ti.com, you can ask questions, share knowledge, explore ideas and help solve problems with fellow engineers.

Design Support *TI's Design Support* Quickly find helpful E2E forums along with design support tools and contact information for technical support.

11.3 Trademarks

D-CAP, D-CAP2, E2E are trademarks of Texas Instruments.
All other trademarks are the property of their respective owners.

11.4 Electrostatic Discharge Caution



This integrated circuit can be damaged by ESD. Texas Instruments recommends that all integrated circuits be handled with appropriate precautions. Failure to observe proper handling and installation procedures can cause damage.

ESD damage can range from subtle performance degradation to complete device failure. Precision integrated circuits may be more susceptible to damage because very small parametric changes could cause the device not to meet its published specifications.

11.5 Glossary

[SLYZ022](#) — *TI Glossary*.

This glossary lists and explains terms, acronyms, and definitions.

12 Mechanical, Packaging, and Orderable Information

The following pages include mechanical, packaging, and orderable information. This information is the most current data available for the designated devices. This data is subject to change without notice and revision of this document. For browser-based versions of this data sheet, refer to the left-hand navigation.

PACKAGING INFORMATION

Orderable Device	Status (1)	Package Type	Package Drawing	Pins	Package Qty	Eco Plan (2)	Lead finish/ Ball material (6)	MSL Peak Temp (3)	Op Temp (°C)	Device Marking (4/5)	Samples
TPS51916RUKR	ACTIVE	WQFN	RUK	20	3000	RoHS & Green	NIPDAU	Level-2-260C-1 YEAR	-40 to 85	51916	Samples
TPS51916RUKT	ACTIVE	WQFN	RUK	20	250	RoHS & Green	NIPDAU	Level-2-260C-1 YEAR	-40 to 85	51916	Samples

(1) The marketing status values are defined as follows:

ACTIVE: Product device recommended for new designs.

LIFEBUY: TI has announced that the device will be discontinued, and a lifetime-buy period is in effect.

NRND: Not recommended for new designs. Device is in production to support existing customers, but TI does not recommend using this part in a new design.

PREVIEW: Device has been announced but is not in production. Samples may or may not be available.

OBSOLETE: TI has discontinued the production of the device.

(2) **RoHS:** TI defines "RoHS" to mean semiconductor products that are compliant with the current EU RoHS requirements for all 10 RoHS substances, including the requirement that RoHS substance do not exceed 0.1% by weight in homogeneous materials. Where designed to be soldered at high temperatures, "RoHS" products are suitable for use in specified lead-free processes. TI may reference these types of products as "Pb-Free".

RoHS Exempt: TI defines "RoHS Exempt" to mean products that contain lead but are compliant with EU RoHS pursuant to a specific EU RoHS exemption.

Green: TI defines "Green" to mean the content of Chlorine (Cl) and Bromine (Br) based flame retardants meet JS709B low halogen requirements of <=1000ppm threshold. Antimony trioxide based flame retardants must also meet the <=1000ppm threshold requirement.

(3) MSL, Peak Temp. - The Moisture Sensitivity Level rating according to the JEDEC industry standard classifications, and peak solder temperature.

(4) There may be additional marking, which relates to the logo, the lot trace code information, or the environmental category on the device.

(5) Multiple Device Markings will be inside parentheses. Only one Device Marking contained in parentheses and separated by a "~" will appear on a device. If a line is indented then it is a continuation of the previous line and the two combined represent the entire Device Marking for that device.

(6) Lead finish/Ball material - Orderable Devices may have multiple material finish options. Finish options are separated by a vertical ruled line. Lead finish/Ball material values may wrap to two lines if the finish value exceeds the maximum column width.

Important Information and Disclaimer:The information provided on this page represents TI's knowledge and belief as of the date that it is provided. TI bases its knowledge and belief on information provided by third parties, and makes no representation or warranty as to the accuracy of such information. Efforts are underway to better integrate information from third parties. TI has taken and continues to take reasonable steps to provide representative and accurate information but may not have conducted destructive testing or chemical analysis on incoming materials and chemicals. TI and TI suppliers consider certain information to be proprietary, and thus CAS numbers and other limited information may not be available for release.

In no event shall TI's liability arising out of such information exceed the total purchase price of the TI part(s) at issue in this document sold by TI to Customer on an annual basis.

RUK0020B

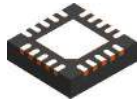

PACKAGE OUTLINE

WQFN - 0.8 mm max height

PLASTIC QUAD FLATPACK - NO LEAD

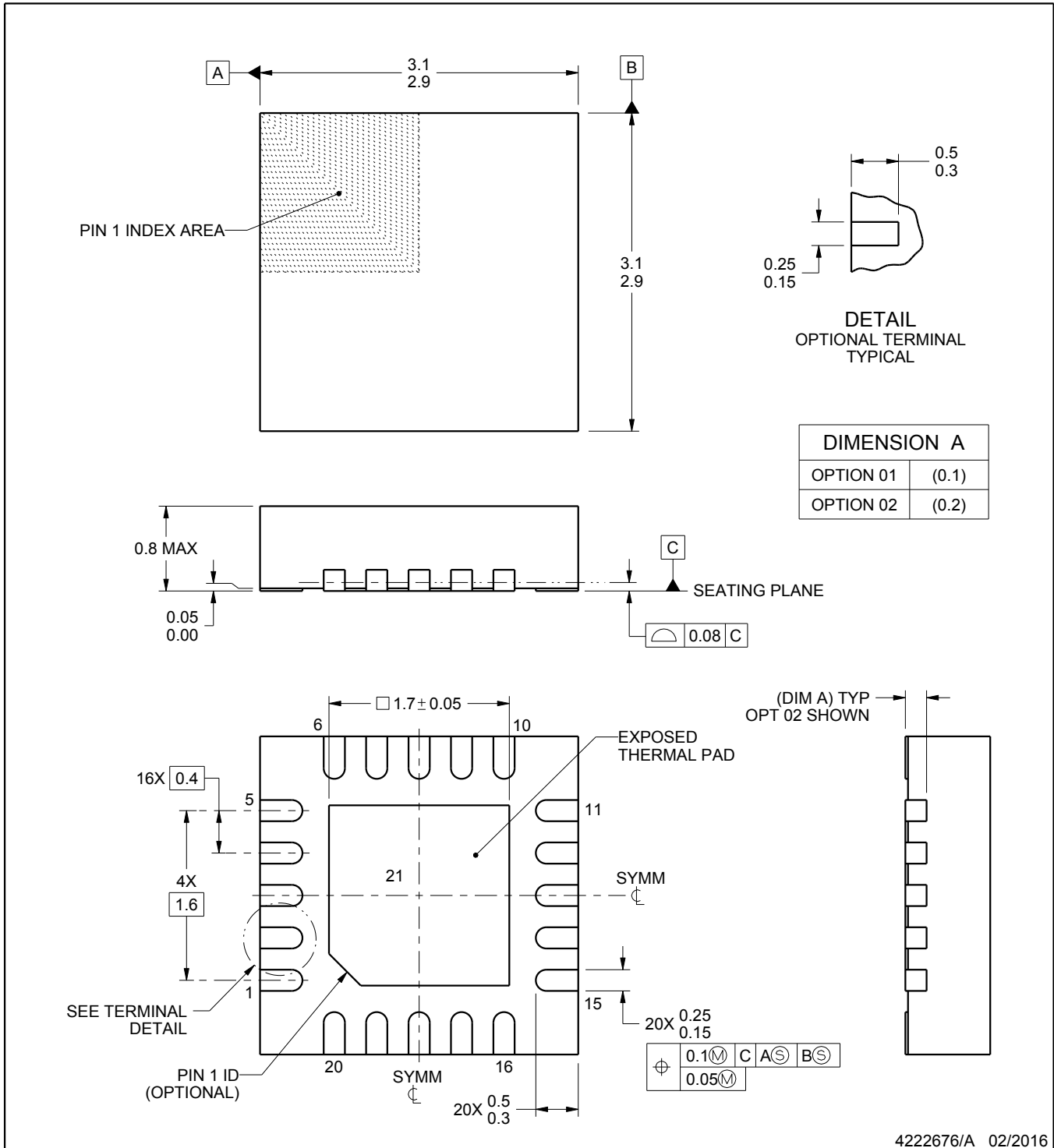

4222676/A 02/2016

NOTES:

1. All linear dimensions are in millimeters. Any dimensions in parenthesis are for reference only. Dimensioning and tolerancing per ASME Y14.5M.
2. This drawing is subject to change without notice.
3. The package thermal pad must be soldered to the printed circuit board for thermal and mechanical performance.

EXAMPLE BOARD LAYOUT

RUK0020B

WQFN - 0.8 mm max height

PLASTIC QUAD FLATPACK - NO LEAD

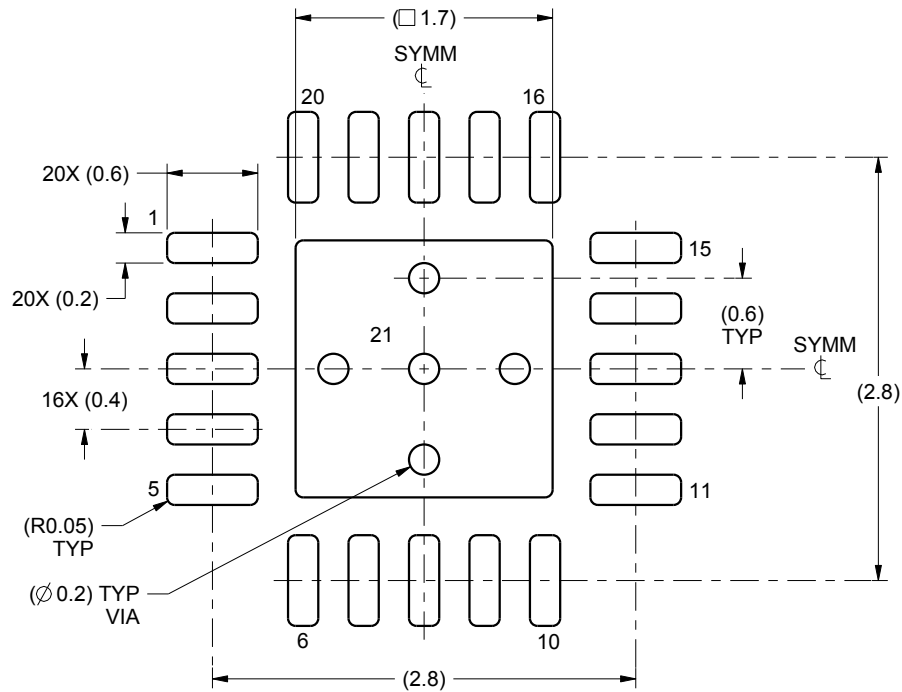

LAND PATTERN EXAMPLE
SCALE:20X

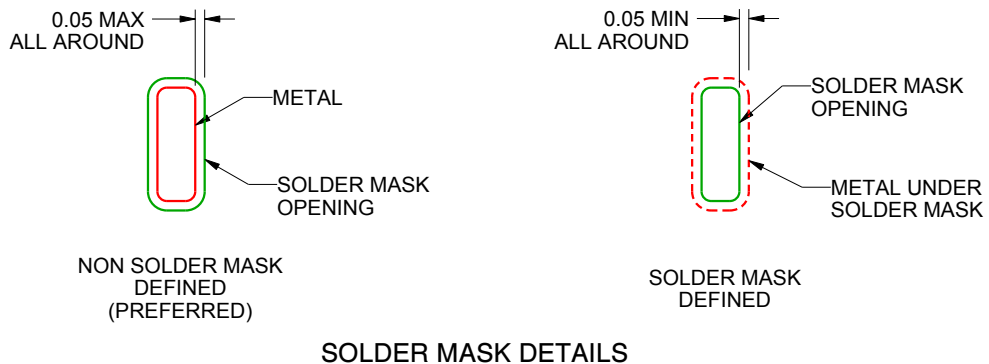

SOLDER MASK DETAILS

4222676/A 02/2016

NOTES: (continued)

4. This package is designed to be soldered to a thermal pad on the board. For more information, see Texas Instruments literature number SLUA271 (www.ti.com/lit/sluea271).
5. Vias are optional depending on application, refer to device data sheet. If any vias are implemented, refer to their locations shown on this view. It is recommended that vias under paste be filled, plugged or tented.

EXAMPLE STENCIL DESIGN

RUK0020B

WQFN - 0.8 mm max height

PLASTIC QUAD FLATPACK - NO LEAD

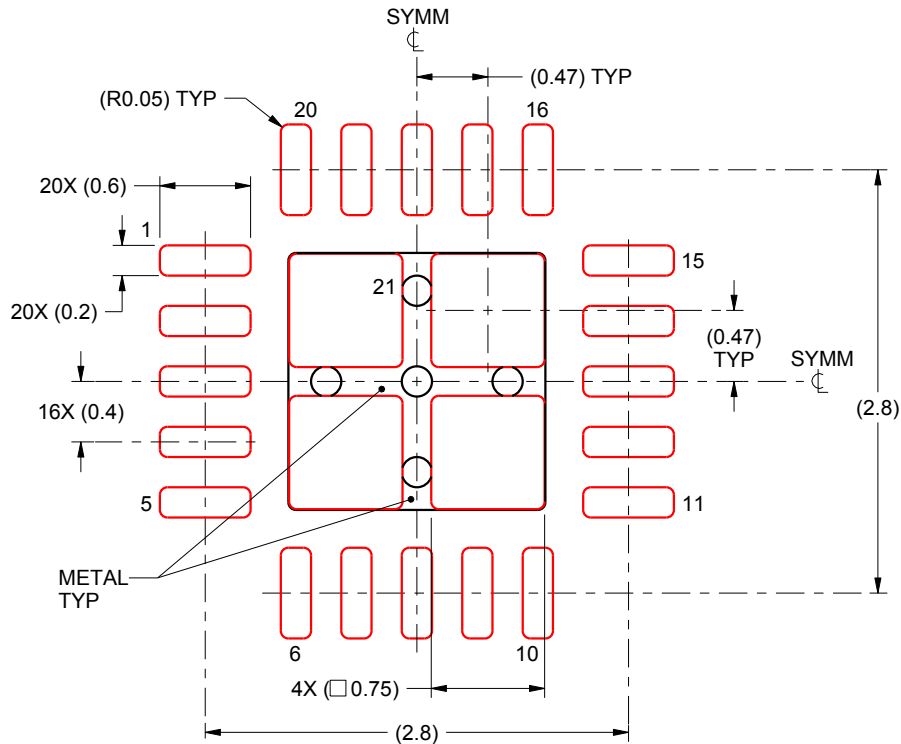

SOLDER PASTE EXAMPLE BASED ON 0.1 mm THICK STENCIL

EXPOSED PAD 21:
78% PRINTED SOLDER COVERAGE BY AREA UNDER PACKAGE
SCALE:20X

4222676/A 02/2016

NOTES: (continued)

6. Laser cutting apertures with trapezoidal walls and rounded corners may offer better paste release. IPC-7525 may have alternate design recommendations.

IMPORTANT NOTICE AND DISCLAIMER

TI PROVIDES TECHNICAL AND RELIABILITY DATA (INCLUDING DATA SHEETS), DESIGN RESOURCES (INCLUDING REFERENCE DESIGNS), APPLICATION OR OTHER DESIGN ADVICE, WEB TOOLS, SAFETY INFORMATION, AND OTHER RESOURCES "AS IS" AND WITH ALL FAULTS, AND DISCLAIMS ALL WARRANTIES, EXPRESS AND IMPLIED, INCLUDING WITHOUT LIMITATION ANY IMPLIED WARRANTIES OF MERCHANTABILITY, FITNESS FOR A PARTICULAR PURPOSE OR NON-INFRINGEMENT OF THIRD PARTY INTELLECTUAL PROPERTY RIGHTS.

These resources are intended for skilled developers designing with TI products. You are solely responsible for (1) selecting the appropriate TI products for your application, (2) designing, validating and testing your application, and (3) ensuring your application meets applicable standards, and any other safety, security, regulatory or other requirements.

These resources are subject to change without notice. TI grants you permission to use these resources only for development of an application that uses the TI products described in the resource. Other reproduction and display of these resources is prohibited. No license is granted to any other TI intellectual property right or to any third party intellectual property right. TI disclaims responsibility for, and you will fully indemnify TI and its representatives against, any claims, damages, costs, losses, and liabilities arising out of your use of these resources.

TI's products are provided subject to [TI's Terms of Sale](#) or other applicable terms available either on ti.com or provided in conjunction with such TI products. TI's provision of these resources does not expand or otherwise alter TI's applicable warranties or warranty disclaimers for TI products.

TI objects to and rejects any additional or different terms you may have proposed.

Mailing Address: Texas Instruments, Post Office Box 655303, Dallas, Texas 75265
Copyright © 2021, Texas Instruments Incorporated