

NOTES:

1. PARTS ARE SHIPPED NON-ASSEMBLED.
2. SEE SHEET 4 FOR PACKAGING PLAN.

REVISIONS			
REV.	DESCRIPTION	DATE	APPROVED
B	Engineering Release	7/11/2018	G.O.

PART NUMBER CONFIGURATION,

LPV2-XXXXX-XXX

LED COLOR (SEE PAGE 3)

LIGHT PIPE CALLOUT (SEE PAGE 2, TABLES A & B)

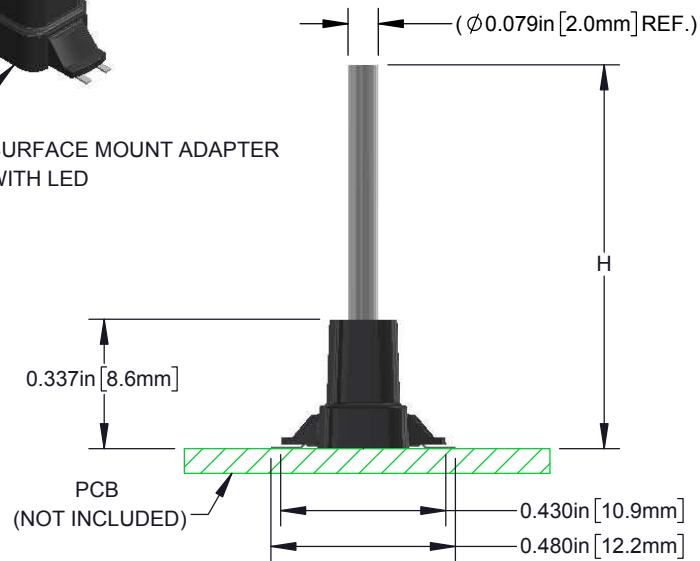
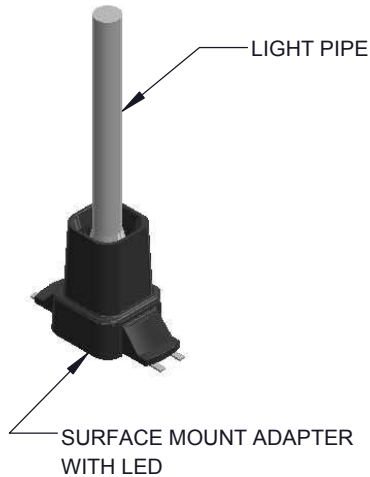

FLAT FACE LENS

DIMENSIONS ARE APPLICABLE TO BOTH LENS FACES UNLESS OTHERWISE NOTED

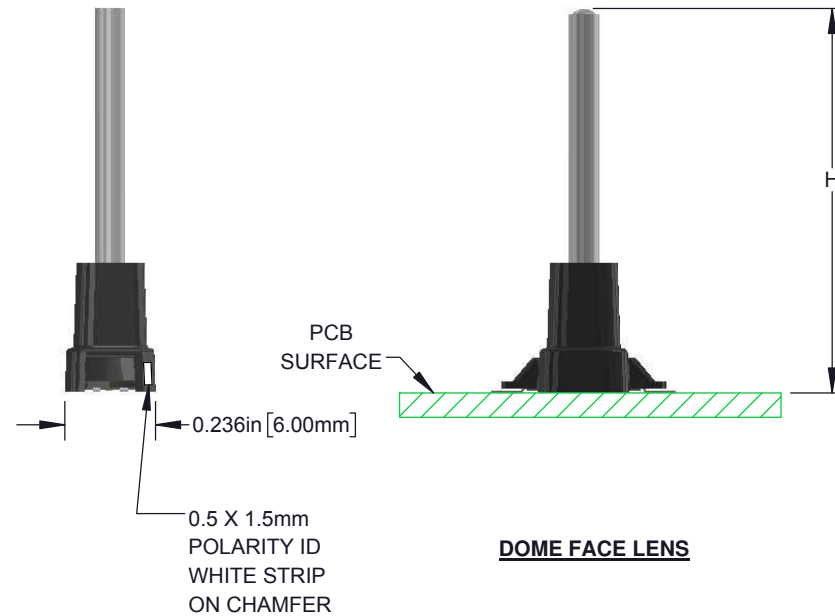

DOME FACE LENS

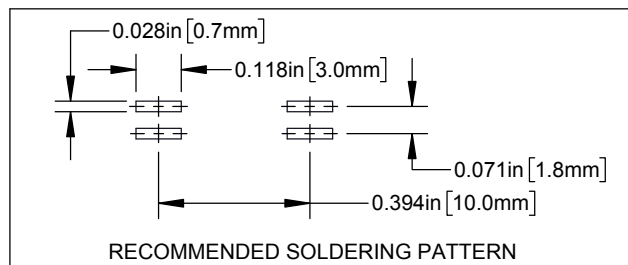

RECOMMENDED SOLDERING PATTERN

STANDARD TOLERANCE (UNLESS OTHERWISE SPECIFIED)		 4 THOMAS, IRVINE, CA. 92618 TEL: (949) 951-8808 FAX: (949) 951-3974	
DECIMALS .X ± .1 .XX ± .02 .XXX ± .010			
DESIGNED: K. BARON		DATE: 07/11/18	
REVISED: N/A		DATE: N/A	
CHECKED: TD. NGUYEN		DATE: 07/11/18	
TITLE: BIVAR LIGHT PIPE SYSTEM SAT VERTICAL, 2MM, SINGLE STATION		PART NO: LPV2-XXXXX-XXX	
CAGE CODE: 32559		REVISION: B	
SCALE: 2:1		SHEET # 1 OF 5	
CAD GENERATED DOCUMENT, DO NOT MEASURE DRAWING			

REVISIONS			
REV.	DESCRIPTION	DATE	APPROVED
	See Sheet 1		

STANDARD ORDERING INFORMATION

TABLE A - FLAT FACE LENS	
PART NO.	H ± .01
LPV2-0350F-XXX	0.350 [8.9mm]
LPV2-0400F-XXX	0.400 [10.2mm]
LPV2-0450F-XXX	0.450 [11.4mm]
LPV2-0500F-XXX	0.500 [12.7mm]
LPV2-0550F-XXX	0.550 [14.0mm]
LPV2-0600F-XXX	0.600 [15.2mm]
LPV2-0750F-XXX	0.750 [19.1mm]
LPV2-1000F-XXX	1.000 [25.4mm]
LPV2-1250F-XXX	1.250 [31.8mm]
LPV2-1500F-XXX	1.500 [38.1mm]
LPV2-1750F-XXX	1.750 [44.5mm]
LPV2-2000F-XXX	2.000 [50.8mm]

TABLE B - DOME FACE LENS	
PART NO.	H ± .01
LPV2-0350D-XXX	0.350 [8.9mm]
LPV2-0400D-XXX	0.400 [10.2mm]
LPV2-0450D-XXX	0.450 [11.4mm]
LPV2-0500D-XXX	0.500 [12.7mm]
LPV2-0550D-XXX	0.550 [14.0mm]
LPV2-0600D-XXX	0.600 [15.2mm]
LPV2-0750D-XXX	0.750 [19.1mm]
LPV2-1000D-XXX	1.000 [25.4mm]
LPV2-1250D-XXX	1.250 [31.8mm]
LPV2-1500D-XXX	1.500 [38.1mm]
LPV2-1750D-XXX	1.750 [44.5mm]
LPV2-2000D-XXX	2.000 [50.8mm]

BIVAR [®]	
PART NO: LPV2-XXXXX-XXX	REVISION: B
SCALE: NONE	SHEET # 2 OF 5
CAD GENERATED DOCUMENT, DO NOT MEASURE DRAWING	

Order Code XXX	Emitted Color	Peak Wave L.	Electro-Optical Data @20mA, 25°C				Polarity Diagram
		λ_p [nm]	V_f [V]			I_v [mcd]	
		Chroma	MIN	TYP	MAX	TYP	
R130	Red	640	1.7	2.0	2.5	130	FIGURE A
R480	Red	630	1.7	2.0	2.5	480	FIGURE B
A220	Amber	610	1.7	2.0	2.5	220	
O170	Orange	590	1.7	2.0	2.5	170	
Y50	Yellow	570	1.7	2.0	2.5	50	
G850	Green	520	2.8	3.2	3.7	850	
B150	Blue	465	2.8	3.2	3.7	150	
W305	White	X = 0.308 Y = 0.305	2.8	3.0	3.7	1750	
OY	Orange	590	1.7	2.0	2.5	190	
	Yellow	572	1.7	2.0	2.5	60	
RY	Red	640	1.7	2.0	2.5	110	FIGURE D
	Yellow	572	1.7	2.0	2.5	55	
RG	Red	640	1.7	2.0	2.5	200	FIGURE E
	Green	520	2.8	3.2	3.7	810	
RW	Red	630	1.7	2.0	2.5	130	FIGURE F
	White	X = 0.28 Y = 0.29	2.8	3.2	3.7	520	
RB	Red	650	1.7	2.0	2.5	80	FIGURE G
	Blue	465	2.8	3.2	3.7	150	
RGB	Red	643	1.7	2.0	2.5	95	FIGURE H
	Green	515	2.8	3.3	3.7	730	
	Blue	460	2.8	3.3	3.7	120	

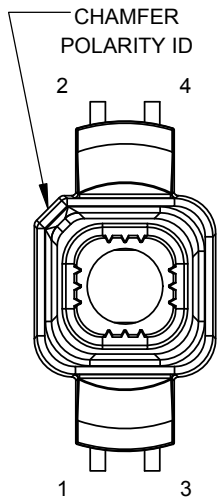

Note: 10% Duty Cycle, Pulse Width \leq 0.1msec for Peak If.

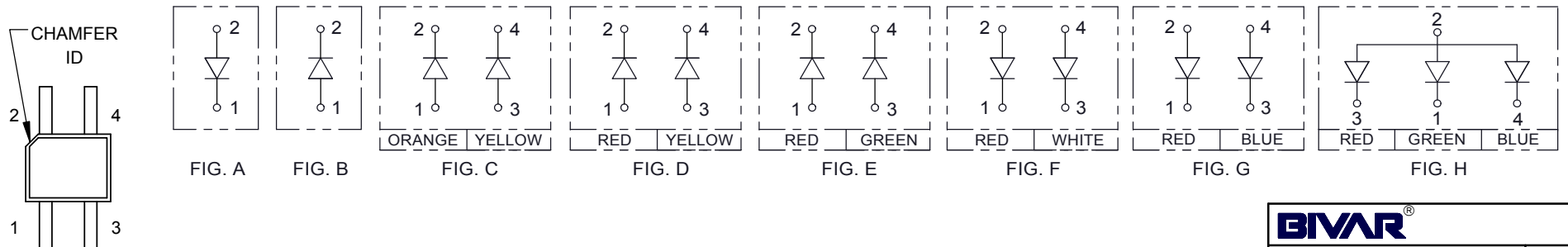

BIVAR [®]	
PART NO: LPV2-XXXXX-XXX	REVISION: B
SCALE: 2:1	SHEET # 3 OF 5
CAD GENERATED DOCUMENT, DO NOT MEASURE DRAWING	

PACKAGING PLAN

PARTS ARE SHIPPED IN QUANTITY OF 400 AS IN THE FOLLOWING:

1. ONE BAG CONTAINING FOUR LIGHT PIPE PACKAGES, 100 EACH, AND ONE LEVEL 4 MOISTURE SEALED TRAY WITH 400 SURFACE MOUNT ADAPTERS.
2. BAG SIZE IS APPROXIMATELY 16 X 18 INCHES (406.4 X 457.2 mm).
3. TRAY SIZE IS APPROXIMATELY 10 X 14 X 0.6 INCHES (254 X 355.6 X 15.2 mm), INCLUDING TOP COVER AND BOTTOM TRAY. ADAPTERS ARE ARRANGED AS SHOWN IN FIGURE 1.

10 ADAPTERS IN EACH POCKET

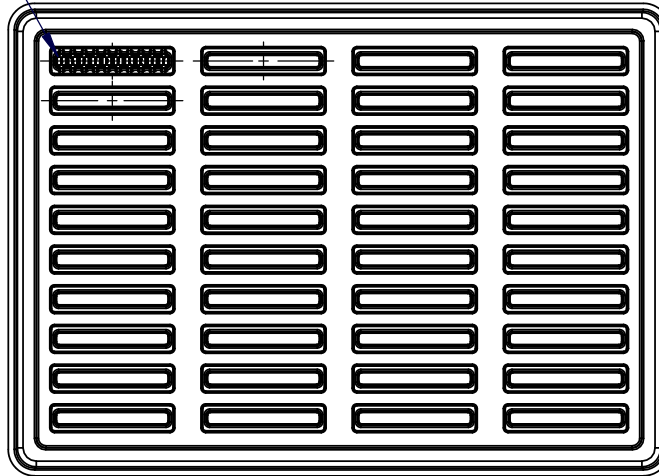
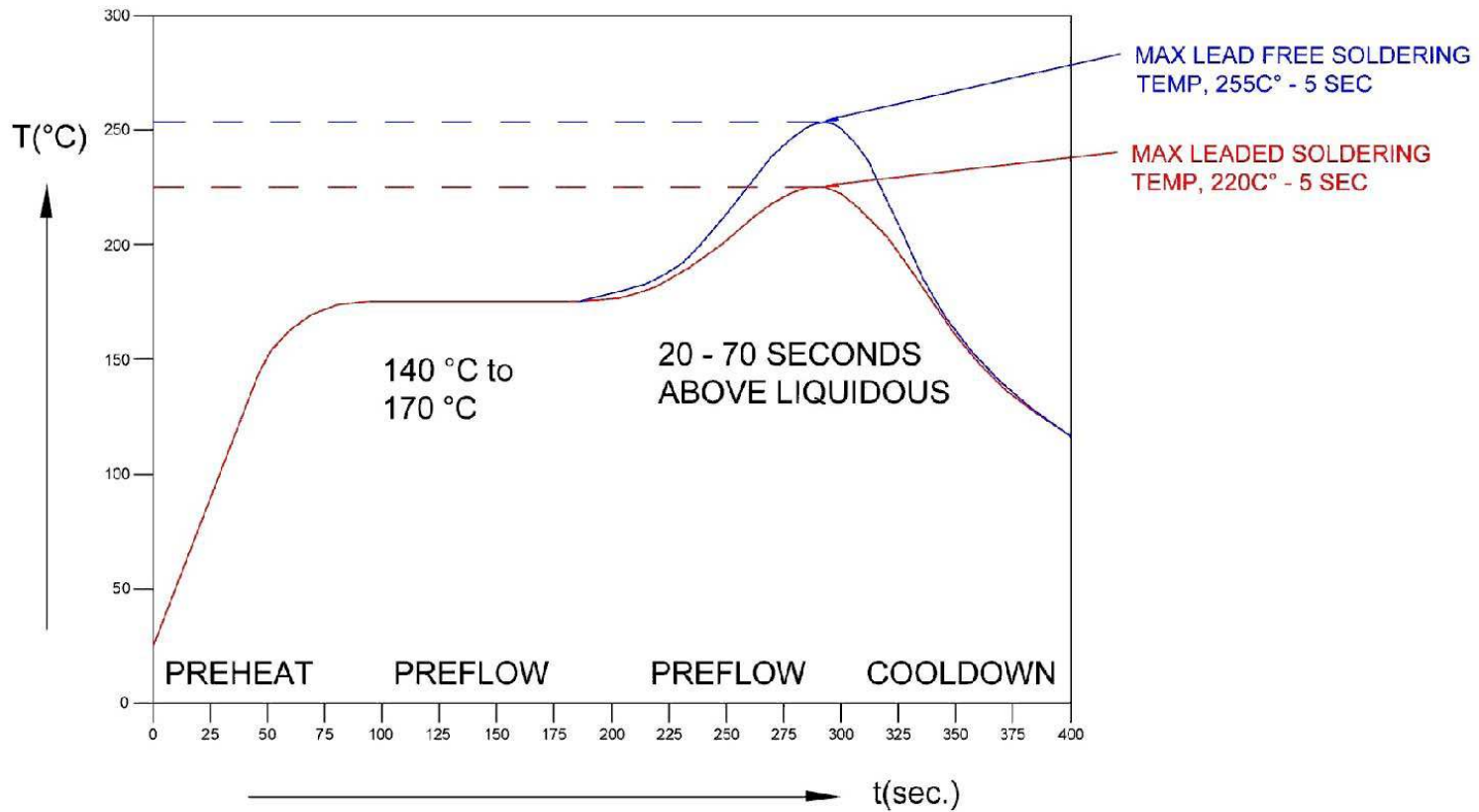

FIGURE 1
BOTTOM TRAY
4 X 10 POCKETS

BIVAR [®]		REVISION:
PART NO: LPV2-XXXXX-XXX		B
SCALE: NONE	SHEET # 4 OF 5	
CAD GENERATED DOCUMENT, DO NOT MEASURE DRAWING		

RECOMMENDED REFLOW SOLDERING PROFILE



NOTE:

1. DO NOT CLEAN AFTER SOLDERING. ONLY USE NO-CLEAN SOLDER PASTE.

BIVAR [®]		REVISION:
PART NO: LPV2-XXXXX-XXX		B
SCALE: NONE	SHEET # 5 OF 5	
CAD GENERATED DOCUMENT, DO NOT MEASURE DRAWING		