

## DMOS dual full bridge driver

### Features

- Operating supply voltage from 8 to 52 V
- 2.8 A output peak current (1.4 A DC)
- $R_{DS(on)}$  0.73  $\Omega$  typ. value @  $T_J = 25\text{ }^\circ\text{C}$
- Operating frequency up to 100 kHz
- Programmable high side overcurrent detection and protection
- Diagnostic output
- Paralleled operation
- Cross conduction protection
- Thermal shutdown
- Under voltage lockout
- Integrated fast free wheeling diodes

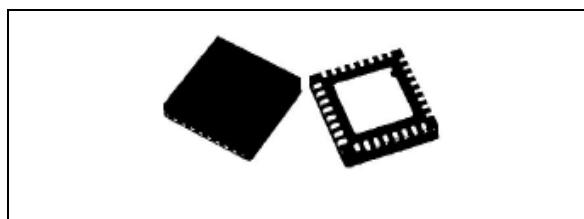

### Description

The L6226Q is a DMOS dual full bridge designed for motor control applications, realized in BCDmultipower technology, which combines isolated DMOS power transistors with CMOS and bipolar circuits on the same chip. Available in QFN32 5x5 package, the L6226Q features thermal shutdown and a non-dissipative overcurrent detection on the high side power MOSFETs plus a diagnostic output that can be easily used to implement the overcurrent protection.

### Applications

- Bipolar stepper motor
- Dual or quad DC motor

**Figure 1. Block diagram**

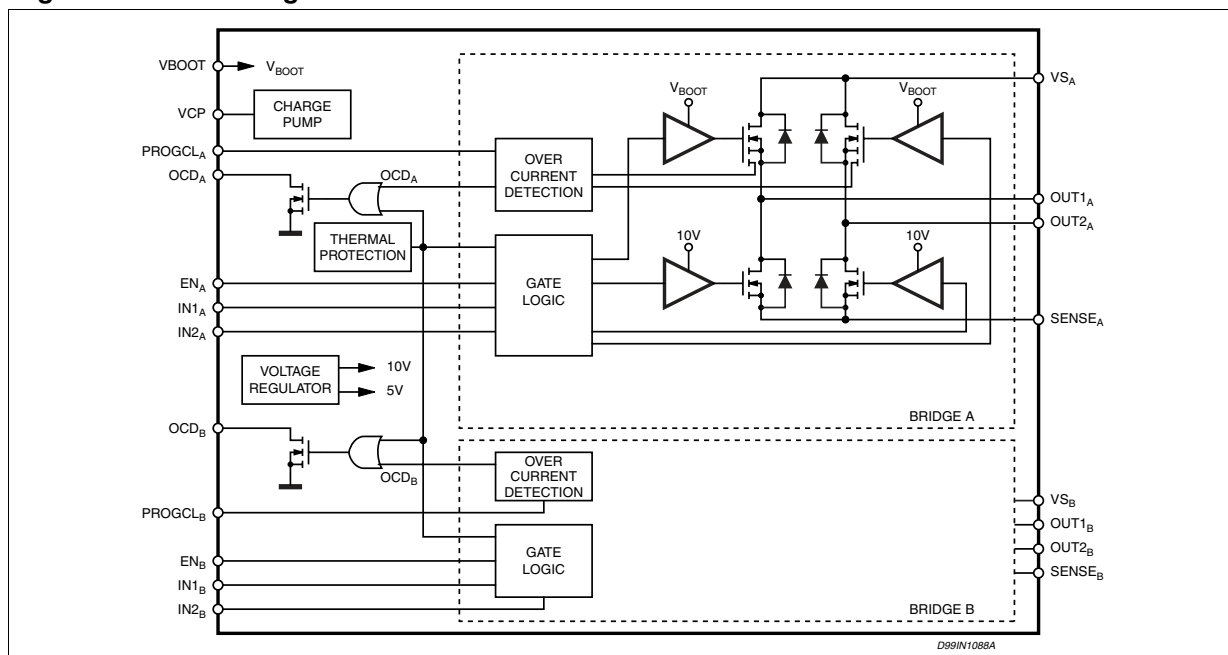

# Contents

- 1      Electrical data ..... 3**
  - 1.1    Absolute maximum ratings ..... 3
  - 1.2    Recommended operating conditions ..... 3
  - 1.3    Thermal data ..... 4
- 2      Pin connection ..... 5**
- 3      Electrical characteristics ..... 7**
- 4      Circuit description ..... 10**
  - 4.1    Power stages and charge pump ..... 10
  - 4.2    Logic inputs ..... 11
  - 4.3    Truth table ..... 12
  - 4.4    Non-dissipative overcurrent detection and protection ..... 12
  - 4.5    Thermal protection ..... 16
- 5      Application information ..... 17**
- 6      Paralleled operation ..... 19**
- 7      Output current capability and IC power dissipation ..... 23**
- 8      Thermal management ..... 24**
- 9      Package mechanical data ..... 25**
- 10     Order codes ..... 27**
- 11     Revision history ..... 28**

# 1 Electrical data

## 1.1 Absolute maximum ratings

Table 1. Absolute maximum ratings

Symbol	Parameter	Parameter	Value	Unit
$V_S$	Supply voltage	$V_{SA} = V_{SB} = V_S$	60	V
$V_{OD}$	Differential voltage between $V_{SA}$ , $OUT1_A$ , $OUT2_A$ , $SENSE_A$ and $V_{SB}$ , $OUT1_B$ , $OUT2_B$ , $SENSE_B$	$V_{SA} = V_{SB} = V_S = 60\text{ V}$ , $V_{SENSEA} = V_{SENSEB} = \text{GND}$	60	V
$OCD_A, OCD_B$	OCD pins voltage range		-0.3 to + 10	V
$PROGCL_A$ , $PROGCL_B$	PROGCL pins voltage range		-0.3 to + 7	V
$V_{BOOT}$	Bootstrap peak voltage	$V_{SA} = V_{SB} = V_S$	$V_S + 10$	V
$V_{IN}, V_{EN}$	Input and enable voltage range		-0.3 to + 7	V
$V_{SENSEA}$ , $V_{SENSEB}$	Voltage range at pins $SENSE_A$ and $SENSE_B$		-1 to + 4	V
$I_{S(\text{peak})}$	Pulsed supply current (for each $V_S$ pin), internally limited by the overcurrent protection	$V_{SA} = V_{SB} = V_S$ , $t_{PULSE} < 1\text{ ms}$	3.55	A
$I_S$	RMS supply current (for each $V_S$ pin)	$V_{SA} = V_{SB} = V_S$	1.4	A
$T_{stg}, T_{OP}$	Storage and operating temperature range		-40 to 150	°C

## 1.2 Recommended operating conditions

Table 2. Recommended operating conditions

Symbol	Parameter	Parameter	Min	Max	Unit
$V_S$	Supply voltage	$V_{SA} = V_{SB} = V_S$	8	52	V
$V_{OD}$	Differential voltage between $V_{SA}$ , $OUT1_A$ , $OUT2_A$ , $SENSE_A$ and $V_{SB}$ , $OUT1_B$ , $OUT2_B$ , $SENSE_B$	$V_{SA} = V_{SB} = V_S$ , $V_{SENSEA} = V_{SENSEB}$		52	V
$V_{SENSEA}$ , $V_{SENSEB}$	Voltage range at pins $SENSE_A$ and $SENSE_B$	(pulsed $t_W < t_{rr}$ ) (DC)	-6 -1	6 1	V V
$I_{OUT}$	RMS output current			1.4	A
$T_J$	Operating junction temperature		-25	+125	°C
$f_{sw}$	Switching frequency			100	kHz

## 1.3 Thermal data

**Table 3. Thermal data**

Symbol	Parameter	Value	Unit
$R_{th(JA)}$	Thermal resistance junction-ambient max. <sup>(1)</sup>	42	°C/W

1. Mounted on a double-layer FR4 PCB with a dissipating copper surface of 0.5 cm<sup>2</sup> on the top side plus 6 cm<sup>2</sup> ground layer connected through 18 via holes (9 below the IC).

## 2 Pin connection

Figure 2. Pin connection (top view)

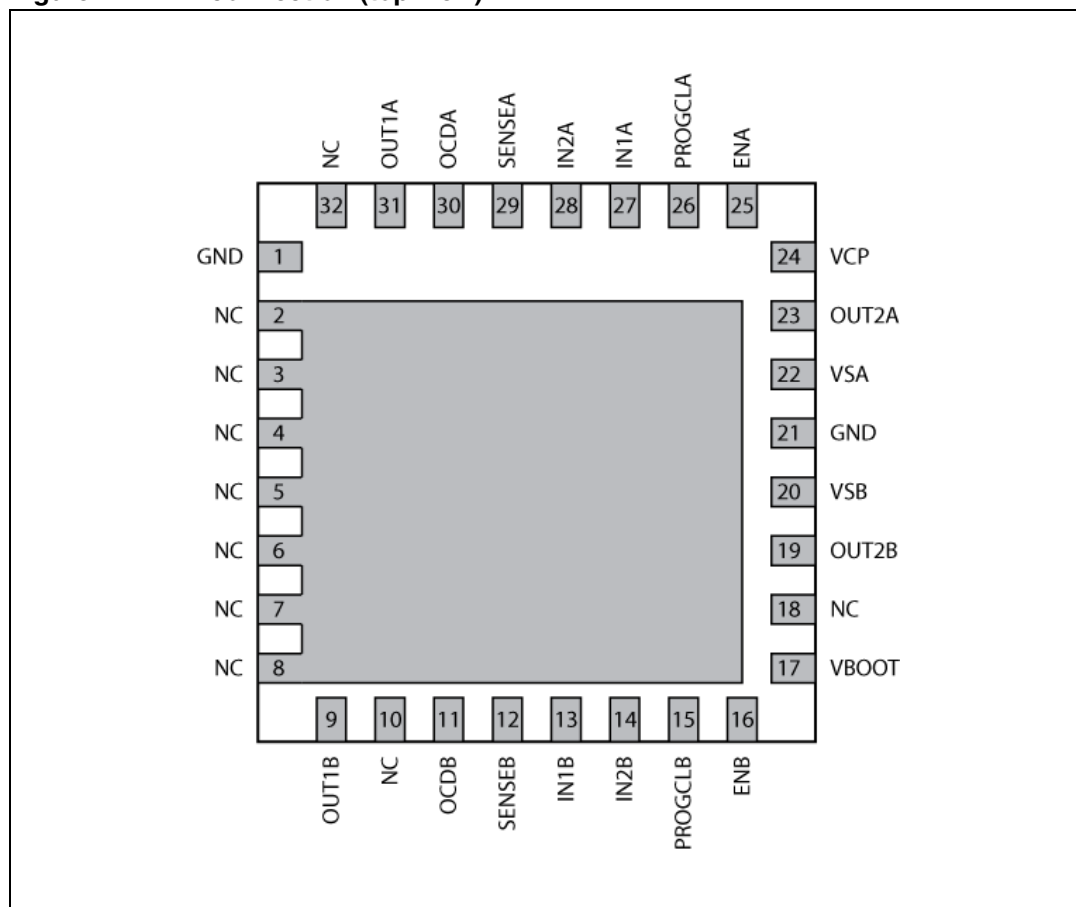

- Note:
- 1 The pins 2 to 8 are connected to die PAD.
  - 2 The die PAD must be connected to GND pin.

Table 4. Pin description

N°	Pin	Type	Function
1, 21	GND	GND	Signal ground terminals.
9	OUT1B	Power output	Bridge B output 1.
11	OCDB	Open drain output	Bridge B overcurrent detection and thermal protection pin. An internal open drain transistor pulls to GND when overcurrent on bridge B is detected or in case of thermal protection.
12	SENSEB	Power supply	Bridge B source pin. This pin must be connected to power ground directly or through a sensing power resistor.
13	IN1B	Logic input	Bridge B input 1
14	IN2B	Logic input	Bridge B input 2
15	PROGCLB	R pin	Bridge B overcurrent level programming. A resistor connected between this pin and ground sets the programmable current limiting value for the bridge B. By connecting this pin to ground the maximum current is set. This pin cannot be left non-connected.
16	ENB	Logic input	Bridge B enable. LOW logic level switches OFF all power MOSFETs of bridge B. If not used, it has to be connected to +5 V.
17	VBOOT	Supply voltage	Bootstrap voltage needed for driving the upper power MOSFETs of both bridge A and bridge B.
19	OUT2B	Power output	Bridge B output 2.
20	VSB	Power supply	Bridge B power supply voltage. It must be connected to the supply voltage together with pin VSA.
22	VSA	Power supply	Bridge A power supply voltage. It must be connected to the supply voltage together with pin VSB.
23	OUT2A	Power output	Bridge A output 2.
24	VCP	Output	Charge pump oscillator output.
25	ENA	Logic input	Bridge A enable. LOW logic level switches OFF all power MOSFETs of bridge A. If not used, it has to be connected to +5 V.
26	PROGCLA	R pin	Bridge A overcurrent level programming. A resistor connected between this pin and ground sets the programmable current limiting value for the bridge A. By connecting this pin to ground the maximum current is set. This pin cannot be left non-connected.
27	IN1A	Logic input	Bridge A logic input 1.
28	IN2A	Logic input	Bridge A logic input 2.
29	SENSEA	Power supply	Bridge A source pin. This pin must be connected to power ground directly or through a sensing power resistor.
30	OCDA	Open drain output	Bridge A overcurrent detection and thermal protection pin. An internal open drain transistor pulls to GND when overcurrent on bridge A is detected or in case of thermal protection.
31	OUT1A	Power output	Bridge A output 1.

### 3 Electrical characteristics

$T_A = 25\text{ °C}$ ,  $V_S = 48\text{ V}$ , unless otherwise specified

**Table 5. Electrical characteristics**

Symbol	Parameter	Test condition	Min	Typ	Max	Unit
$V_{Sth(ON)}$	Turn-on threshold		5.8	6.3	6.8	V
$V_{Sth(OFF)}$	Turn-off threshold		5	5.5	6	V
$I_S$	Quiescent supply current	All bridges OFF; $T_J = -25\text{ °C}$ to $125\text{ °C}$ (1)		5	10	mA
$T_{J(OFF)}$	Thermal shutdown temperature			165		°C
<b>Output DMOS transistors</b>						
$R_{DS(on)}$	High-side + low-side switch ON resistance	$T_J = 25\text{ °C}$		1.47	1.69	$\Omega$
		$T_J = 125\text{ °C}$ (1)		2.35	2.70	$\Omega$
$I_{DSS}$	Leakage current	EN = Low; OUT = $V_S$			2	mA
		EN = Low; OUT = GND	-0.3			mA
<b>Source drain diodes</b>						
$V_{SD}$	Forward ON voltage	$I_{SD} = 2.8\text{ A}$ , EN = LOW		1.15	1.3	V
$t_{rr}$	Reverse recovery time	$I_f = 1.4\text{ A}$		300		ns
$t_{fr}$	Forward recovery time			200		ns
<b>Logic input</b>						
$V_{IL}$	Low level logic input voltage		-0.3		0.8	V
$V_{IH}$	High level logic input voltage		2		7	V
$I_{IL}$	Low level logic input current	GND logic input voltage	-10			$\mu\text{A}$
$I_{IH}$	High level logic input current	7 V logic input voltage			10	$\mu\text{A}$
$V_{th(ON)}$	Turn-on input threshold			1.8	2.0	V
$V_{th(OFF)}$	Turn-off input threshold		0.8	1.3		V
$V_{th(HYS)}$	Input threshold hysteresis		0.25	0.5		V
<b>Switching characteristics</b>						
$t_{D(on)EN}$	Enable to out turn ON delay time (2)	$I_{LOAD} = 1.4\text{ A}$ , resistive load	500		800	ns
$t_{D(on)IN}$	Input to out turn ON delay time	$I_{LOAD} = 1.4\text{ A}$ , resistive load (dead time included)		1.9		$\mu\text{s}$
$t_{RISE}$	Output rise time (2)	$I_{LOAD} = 1.4\text{ A}$ , resistive load	40		250	ns
$t_{D(off)EN}$	Enable to out turn OFF delay time (2)	$I_{LOAD} = 1.4\text{ A}$ , resistive load	500	800	1000	ns
$t_{D(off)IN}$	Input to out turn OFF delay time	$I_{LOAD} = 1.4\text{ A}$ , resistive load	500	800	1000	ns
$t_{FALL}$	Output fall time (2)	$I_{LOAD} = 1.4\text{ A}$ , resistive load	40		250	ns

**Table 5. Electrical characteristics (continued)**

Symbol	Parameter	Test condition	Min	Typ	Max	Unit
$t_{dt}$	Dead time protection		0.5	1		$\mu s$
$f_{CP}$	Charge pump frequency	$-25\text{ }^\circ\text{C} < T_J < 125\text{ }^\circ\text{C}$		0.6	1	MHz
<b>Over current detection</b>						
$I_{s\ over}$	Input supply over current detection threshold	$-25\text{ }^\circ\text{C} < T_J < 125\text{ }^\circ\text{C}; R_{CL} = 39\text{ k}\Omega$	-10%	0.29	+10%	A
		$-25\text{ }^\circ\text{C} < T_J < 125\text{ }^\circ\text{C}; R_{CL} = 5\text{ k}\Omega$	-10%	2.21	+10%	A
		$-25\text{ }^\circ\text{C} < T_J < 125\text{ }^\circ\text{C}; R_{CL} = \text{GND}$	-30%	2.8	+30%	A
$R_{OPDR}$	Open drain ON resistance	$I = 4\text{ mA}$		40	60	$\Omega$
$t_{OCD(ON)}$	OCD turn-on delay time <sup>(3)</sup>	$I = 4\text{ mA}; C_{EN} < 100\text{ pF}$		200		ns
$t_{OCD(OFF)}$	OCD turn-off delay time <sup>(3)</sup>	$I = 4\text{ mA}; C_{EN} < 100\text{ pF}$		100		ns

1. Tested at 25 °C in a restricted range and guaranteed by characterization.
2. See [Figure 3](#)
3. See [Figure 4](#)

**Figure 3. Switching characteristic definition**

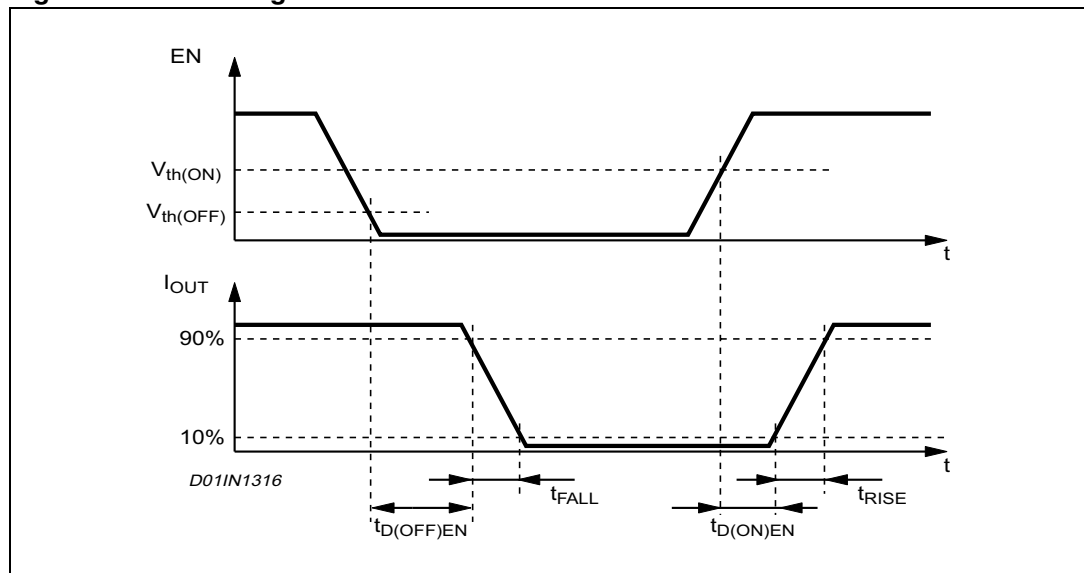
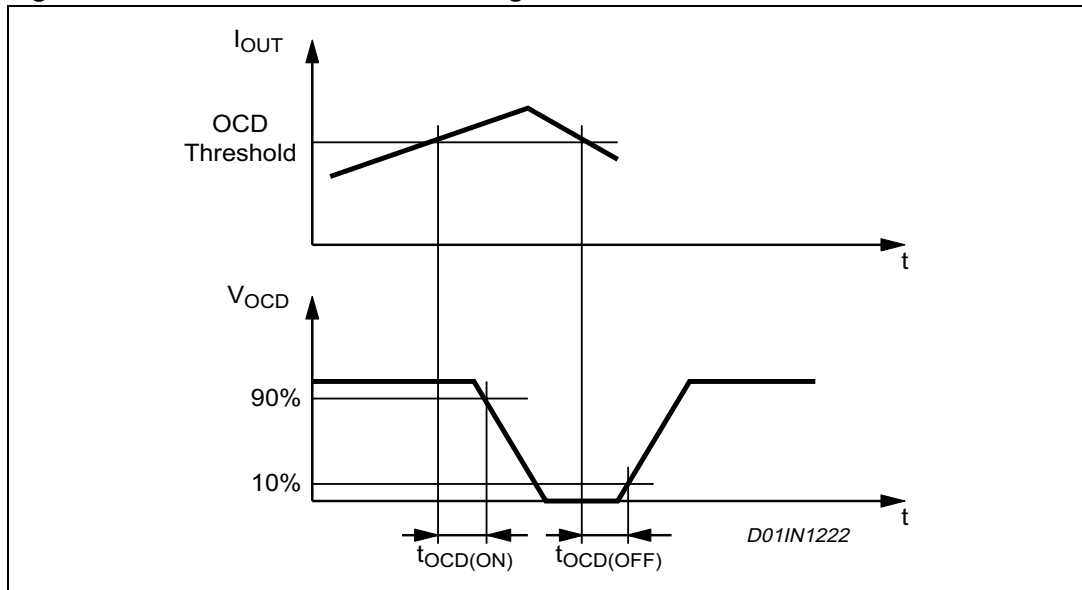



Figure 4. Overcurrent detection timing definition



## 4 Circuit description

### 4.1 Power stages and charge pump

The L6226Q integrates two independent power MOS full bridges. Each power MOS has an  $R_{DS(on)} = 0.73 \Omega$  (typical value @ 25 °C), with intrinsic fast freewheeling diode. Cross conduction protection is achieved using a dead time ( $t_d = 1 \mu s$  typical) between the switch off and switch on of two power MOS in one leg of a bridge.

Using N-channel power MOS for the upper transistors in the bridge requires a gate drive voltage above the power supply voltage. The bootstrapped (VBOOT) supply is obtained through an internal oscillator and few external components to realize a charge pump circuit as shown in [Figure 5](#). The oscillator output (VCP) is a square wave at 600 kHz (typical) with 10 V amplitude. Recommended values/part numbers for the charge pump circuit are shown in [Table 6](#).

**Table 6. Charge pump external components values**

Component	Value
$C_{BOOT}$	220 nF
$C_P$	10 nF
D1	1N4148
D2	1N4148

**Figure 5. Charge pump circuit**

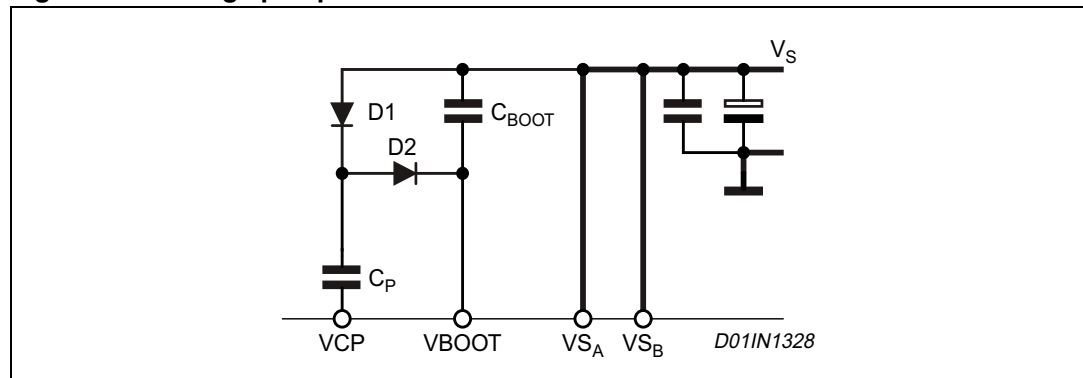

## 4.2 Logic inputs

Pins  $IN1_A$ ,  $IN2_A$ ,  $IN1_B$ ,  $IN2_B$ ,  $EN_A$  and  $EN_B$  are TTL/CMOS and microcontroller compatible logic inputs. The internal structure is shown in [Figure 6](#). Typical value for turn-on and turn-off thresholds are respectively  $V_{thon} = 1.8\text{ V}$  and  $V_{thoff} = 1.3\text{ V}$ .

Pins  $EN_A$  and  $EN_B$  are commonly used to implement overcurrent and thermal protection by connecting them respectively to the outputs  $OCD_A$  and  $OCD_B$ , which are open-drain outputs. If that type of connection is chosen, some care needs to be taken in driving these pins. Two configurations are shown in [Figure 7](#) and [Figure 8](#). If driven by an open drain (collector) structure, a pull-up resistor  $R_{EN}$  and a capacitor  $C_{EN}$  are connected as shown in [Figure 7](#). If the driver is a standard push-pull structure the resistor  $R_{EN}$  and the capacitor  $C_{EN}$  are connected as shown in [Figure 8](#). The resistor  $R_{EN}$  should be chosen in the range from  $2.2\text{ k}\Omega$  to  $180\text{ k}\Omega$ . Recommended values for  $R_{EN}$  and  $C_{EN}$  are respectively  $100\text{ k}\Omega$  and  $5.6\text{ nF}$ . More information on selecting the values is found in the overcurrent protection section.

**Figure 6. Logic inputs internal structure**

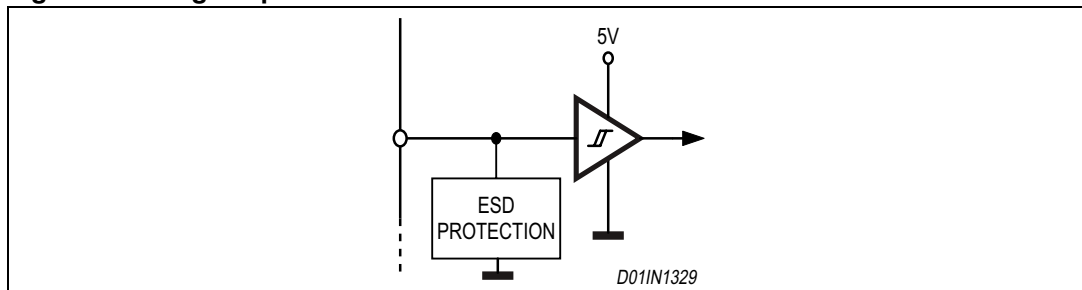

**Figure 7.  $EN_A$  and  $EN_B$  pins open collector driving**

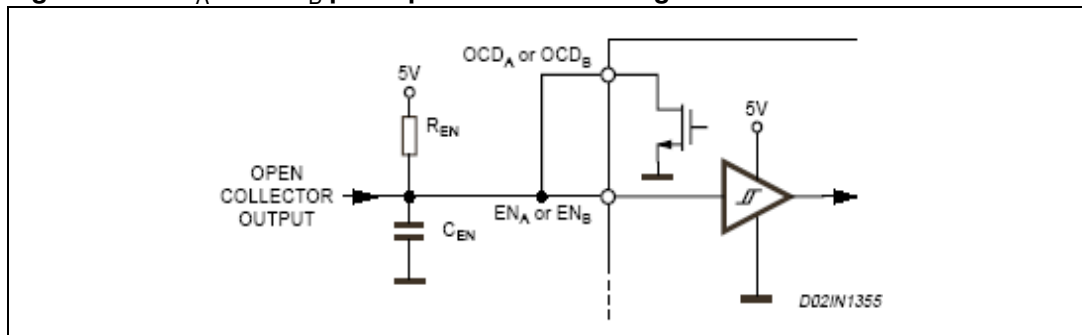

**Figure 8.  $EN_A$  and  $EN_B$  pins push-pull driving**

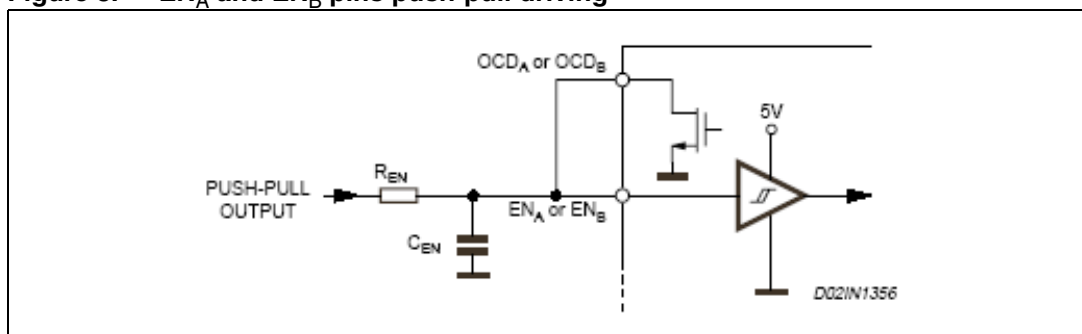

### 4.3 Truth table

Table 7. Truth table

Inputs			Outputs	
EN	IN1	IN2	OUT1	OUT2
L	X <sup>(1)</sup>	X	High Z <sup>(2)</sup>	High Z
H	L	L	GND	GND
H	H	L	Vs	GND
H	L	H	GND	Vs
H	H	H	Vs	Vs

1. X = Don't care
2. High Z = High impedance output

### 4.4 Non-dissipative overcurrent detection and protection

An overcurrent detection circuit (OCD) is integrated. This circuit can be used to provides protection against a short circuit to ground or between two phases of the bridge as well as a roughly regulation of the load current. With this internal over current detection, the external current sense resistor normally used and its associated power dissipation are eliminated. [Figure 9](#) shows a simplified schematic of the overcurrent detection circuit for the bridge A. bridge B is provided of an analogous circuit.

To implement the over current detection, a sensing element that delivers a small but precise fraction of the output current is implemented with each high side power MOS. Since this current is a small fraction of the output current there is very little additional power dissipation. This current is compared with an internal reference current  $I_{REF}$ . When the output current reaches the detection threshold  $I_{SOVER}$  the OCD comparator signals a fault condition. When a fault condition is detected, an internal open drain MOS with a pull down capability of 4 mA connected to OCD pin is turned on. [Figure 10](#) shows the OCD operation.

This signal can be used to regulate the output current simply by connecting the OCD pin to EN pin and adding an external R-C as shown in [Figure 9](#). The off time before recovering normal operation can be easily programmed by means of the accurate thresholds of the logic inputs.

$I_{REF}$  and, therefore, the output current detection threshold are selectable by  $R_{CL}$  value, following the equations:

- $I_{SOVER} = 2.8 \text{ A} \pm 30 \%$  at  $-25 \text{ }^\circ\text{C} < T_J < 125 \text{ }^\circ\text{C}$  if  $R_{CL} = 0 \ \Omega$  (PROGCL connected to GND)
- $I_{SOVER} = \frac{11050}{R_{CL}} \pm 10 \%$  at  $-25 \text{ }^\circ\text{C} < T_J < 125 \text{ }^\circ\text{C}$  if  $5 \text{ k}\Omega < R_{CL} < 40 \text{ k}\Omega$

[Figure 11](#) shows the output current protection threshold versus  $R_{CL}$  value in the range 5 k $\Omega$  to 40 k $\Omega$ .

The disable time  $t_{DISABLE}$  before recovering normal operation can be easily programmed by means of the accurate thresholds of the logic inputs. It is affected whether by  $C_{EN}$  and  $R_{EN}$

values and its magnitude is reported in [Figure 12](#). The delay time  $t_{\text{DELAY}}$  before turning off the bridge when an overcurrent has been detected depends only by  $C_{\text{EN}}$  value. Its magnitude is reported in [Figure 13](#).

$C_{\text{EN}}$  is also used for providing immunity to pin EN against fast transient noises. Therefore the value of  $C_{\text{EN}}$  should be chosen as big as possible according to the maximum tolerable Delay Time and the  $R_{\text{EN}}$  value should be chosen according to the desired Disable Time.

The resistor  $R_{\text{EN}}$  should be chosen in the range from 2.2 k $\Omega$  to 180 k $\Omega$ . Recommended values for  $R_{\text{EN}}$  and  $C_{\text{EN}}$  are respectively 100 k $\Omega$  and 5.6 nF that allow obtaining 200  $\mu\text{s}$  disable time.

**Figure 9. Overcurrent protection simplified schematic**

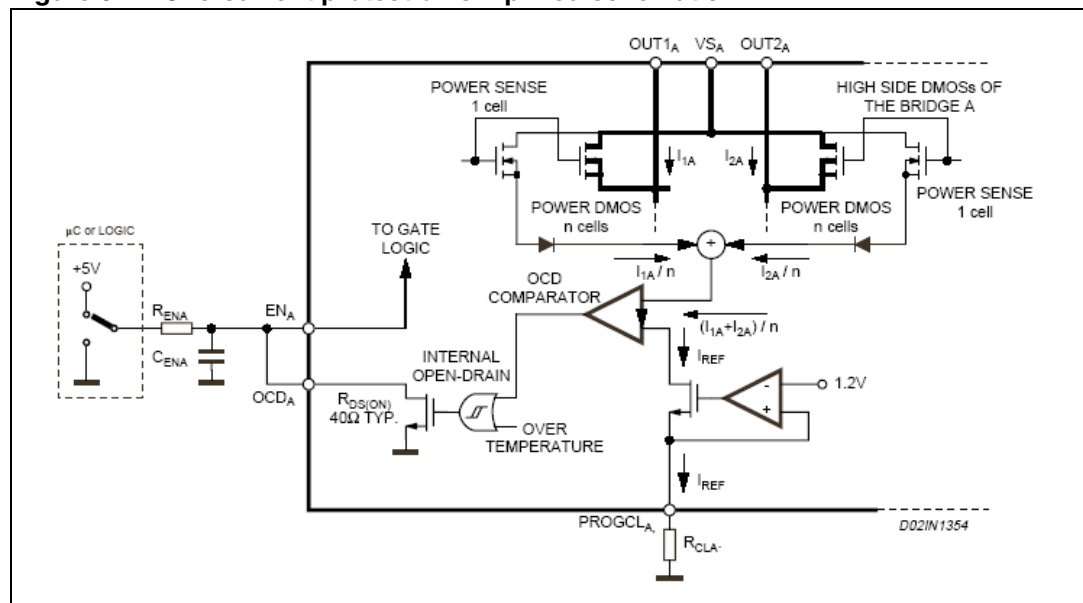

Figure 10. Overcurrent protection waveforms

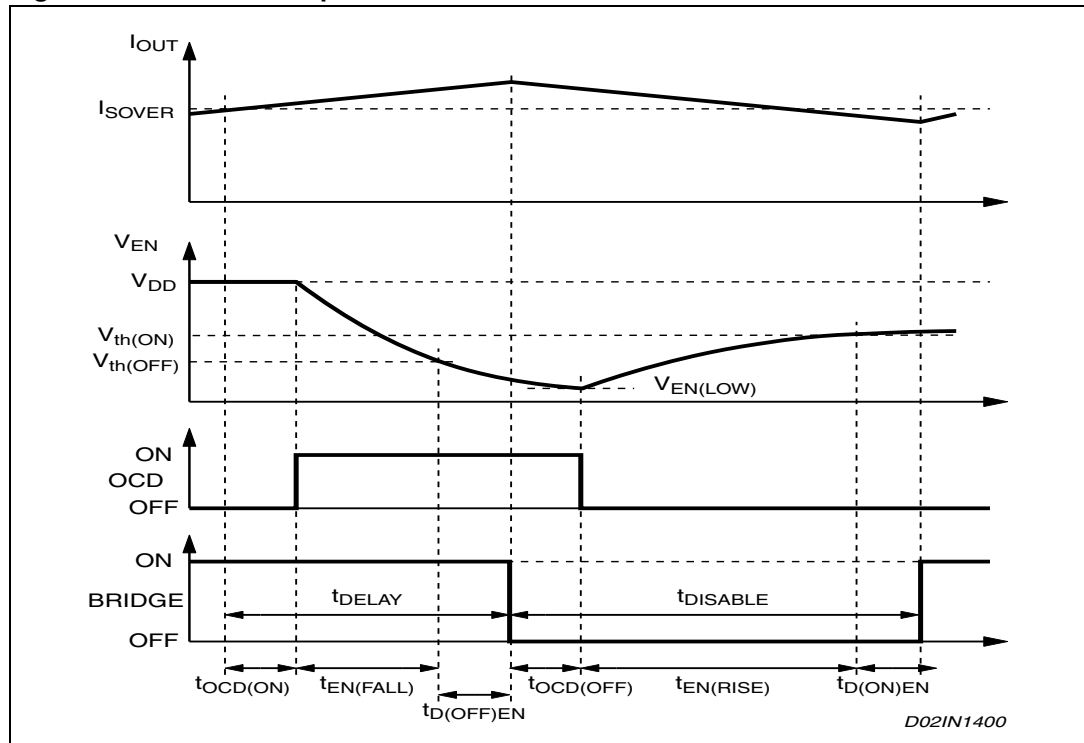

Figure 11. Output current protection threshold versus  $R_{CL}$  value

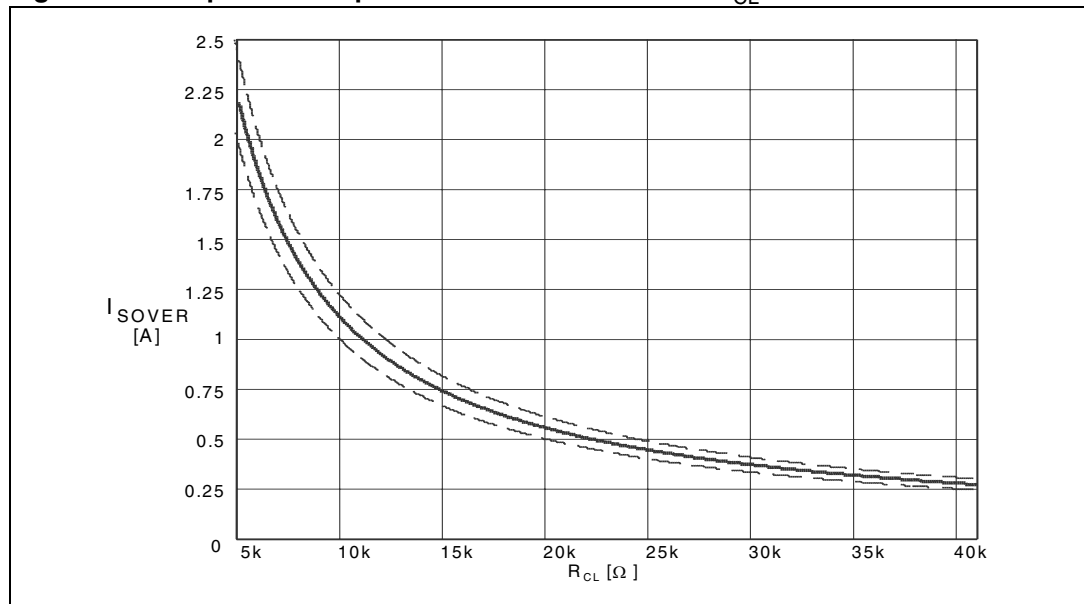

Figure 12.  $t_{\text{DISABLE}}$  versus  $C_{\text{EN}}$  and  $R_{\text{EN}}$  ( $V_{\text{DD}} = 5 \text{ V}$ )

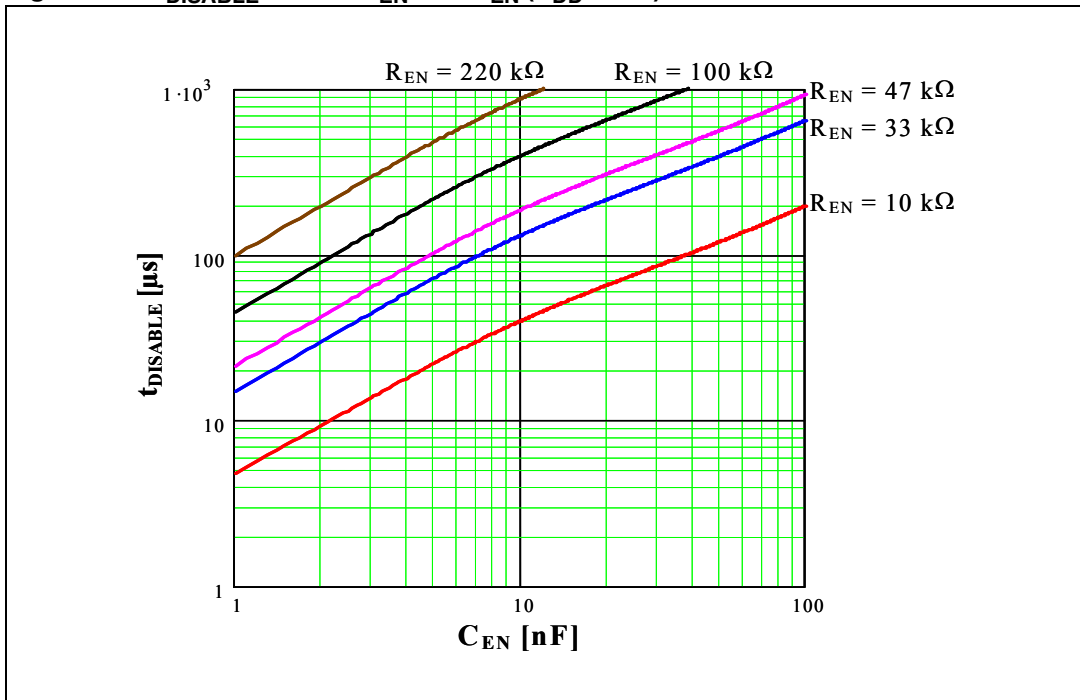
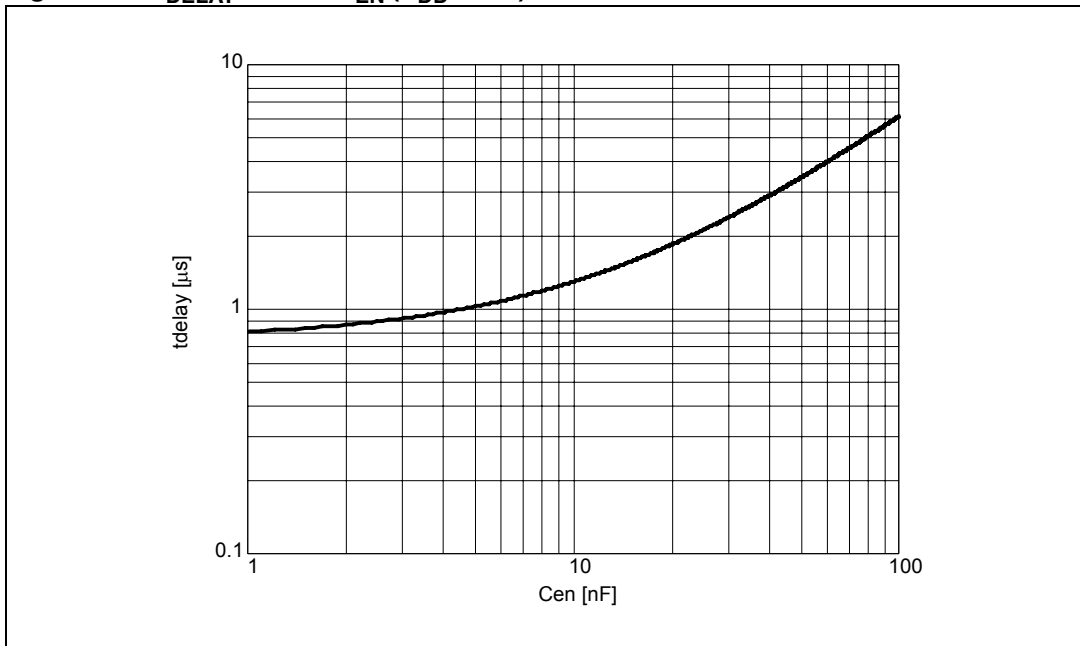

Figure 13.  $t_{\text{DELAY}}$  versus  $C_{\text{EN}}$  ( $V_{\text{DD}} = 5 \text{ V}$ )



## 4.5 Thermal protection

In addition to the overcurrent detection, the L6226Q integrates a thermal protection for preventing the device destruction in case of junction over temperature. It works sensing the die temperature by means of a sensible element integrated in the die. The device switch-off when the junction temperature reaches 165 °C (typ. value) with 15 °C hysteresis (typ. value).



## 5 Application information

A typical application using L6226Q is shown in [Figure 14](#). Typical component values for the application are shown in [Table 8](#). A high quality ceramic capacitor in the range of 100 to 200 nF should be placed between the power pins ( $VS_A$  and  $VS_B$ ) and ground near the L6226Q to improve the high frequency filtering on the power supply and reduce high frequency transients generated by the switching. The capacitors connected from the  $EN_A/OCD_A$  and  $EN_B/OCD_B$  nodes to ground set the shut down time for the bridge A and bridge B respectively when an over current is detected (see overcurrent protection). The two current sources ( $SENSE_A$  and  $SENSE_B$ ) should be connected to power ground with a trace length as short as possible in the layout. To increase noise immunity, unused logic pins are best connected to 5 V (high logic level) or GND (low logic level) (see pin description). It is recommended to keep power ground and Signal Ground separated on PCB.

**Table 8. Component values for typical application**

Component	Value
$C_1$	100 nF
$C_2$	100 $\mu$ F
$C_{BOOT}$	220 nF
$C_P$	10 nF
$C_{ENA}$	5.6 nF
$C_{ENB}$	5.6 nF
$C_{REF}$	68 nF
$D_1$	1N4148
$D_2$	1N4148
$R_{CLA}$	5 k $\Omega$
$R_{CLB}$	5 k $\Omega$
$R_{ENA}$	100 k $\Omega$
$R_{ENB}$	100 k $\Omega$

Figure 14. Typical application

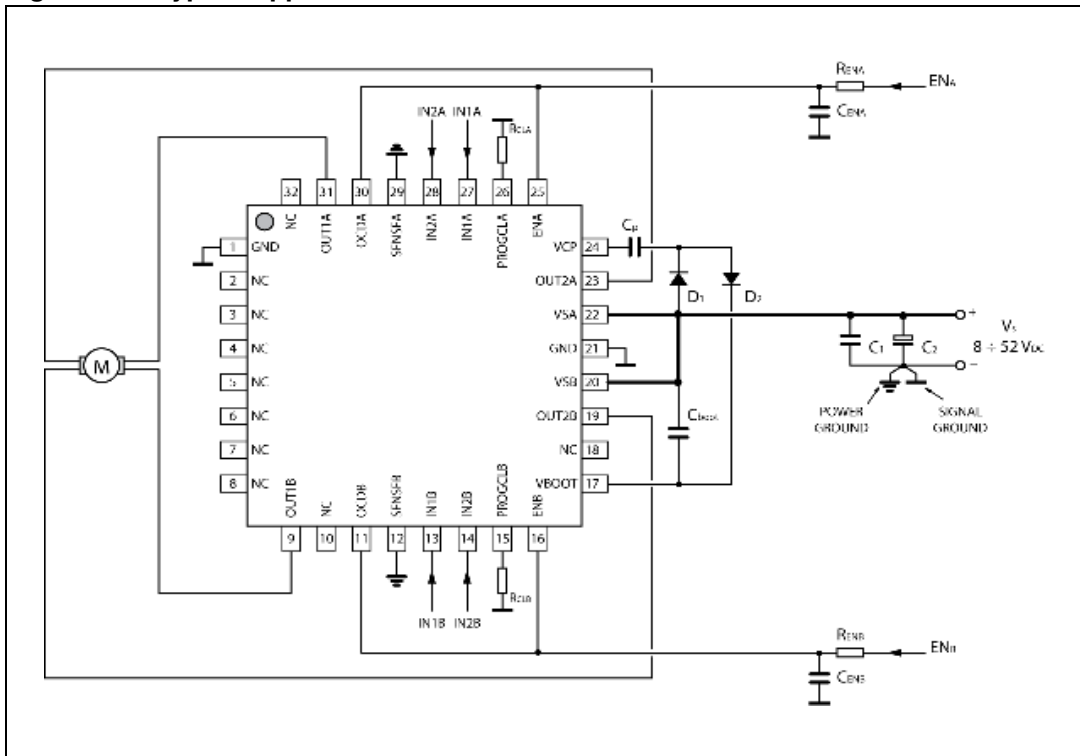

Note: To reduce the IC thermal resistance, therefore improve the dissipation path, the NC pins can be connected to GND.

## 6 Paralleled operation

The outputs of the L6226Q can be paralleled to increase the output current capability or reduce the power dissipation in the device at a given current level. It must be noted, however, that the internal wire bond connections from the die to the power or sense pins of the package must carry current in both of the associated half bridges. When the two halves of one full bridge (for example OUT1<sub>A</sub> and OUT2<sub>A</sub>) are connected in parallel, the peak current rating is not increased since the total current must still flow through one bond wire on the power supply or sense pin. In addition the over current detection senses the sum of the current in the upper devices of each bridge (A or B) so connecting the two halves of one bridge in parallel does not increase the over current detection threshold.

For most applications the recommended configuration is half bridge 1 of bridge A paralleled with the half bridge 1 of the bridge B, and the same for the half bridges 2 as shown in [Figure 15](#). The current in the two devices connected in parallel will share very well since the  $R_{DS(on)}$  of the devices on the same die is well matched.

When connected in this configuration the over current detection circuit, which senses the current in each bridge (A and B), will sense the current in upper devices connected in parallel independently and the sense circuit with the lowest threshold will trip first. With the enables connected in parallel, the first detection of an over current in either upper DMOS device will turn off both bridges. Assuming that the two DMOS devices share the current equally, the resulting over current detection threshold will be twice the minimum threshold set by the resistors  $R_{CLA}$  or  $R_{CLB}$  in [Figure 15](#). It is recommended to use  $R_{CLA} = R_{CLB}$ .

In this configuration the resulting bridge has the following characteristics.

- Equivalent device: full bridge
- $R_{DS(on)}$  0.37  $\Omega$  typ. value @  $T_J = 25\text{ }^\circ\text{C}$
- 2.8 A max RMS load current
- 5.6 A max OCD threshold

Figure 15. Parallel connection for higher current

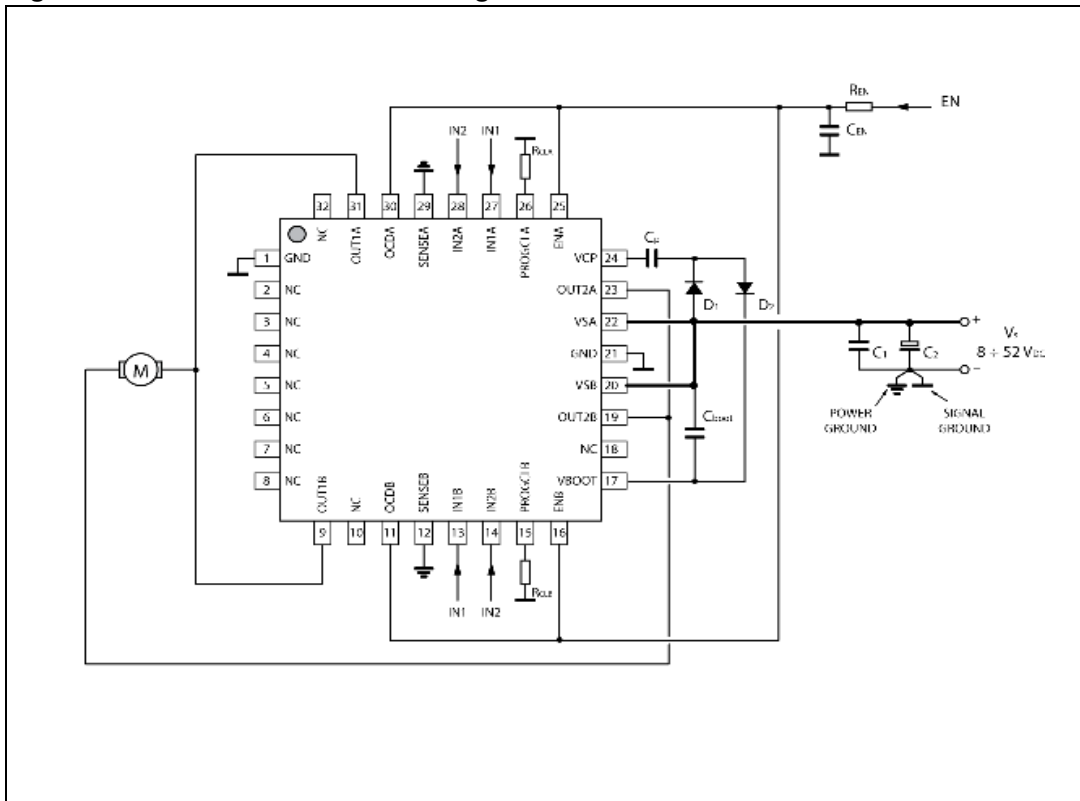

To operate the device in parallel and maintain a lower over current threshold, half bridge 1 and the half bridge 2 of the bridge A can be connected in parallel and the same done for the bridge B as shown in [Figure 16](#). In this configuration, the peak current for each half bridge is still limited by the bond wires for the supply and sense pins so the dissipation in the device will be reduced, but the peak current rating is not increased.

When connected in this configuration the over current detection circuit, senses the sum of the current in upper devices connected in parallel. With the enables connected in parallel, an over current will turn of both bridges. Since the circuit senses the total current in the upper devices, the over current threshold is equal to the threshold set the resistor  $R_{CLA}$  or  $R_{CLB}$  in [Figure 16](#).  $R_{CLA}$  sets the threshold when outputs  $OUT1_A$  and  $OUT2_A$  are high and resistor  $R_{CLB}$  sets the threshold when outputs  $OUT1_B$  and  $OUT2_B$  are high.

It is recommended to use  $R_{CLA} = R_{CLB}$ .

In this configuration, the resulting bridge has the following characteristics.

- Equivalent device: FULL BRIDGE
- $R_{DS(on)}$  0.37  $\Omega$  typ. value @  $T_J = 25\text{ }^\circ\text{C}$
- 1.4 A max RMS load current
- 2.8 A max OCD threshold

Figure 16. Parallel connection with lower overcurrent threshold

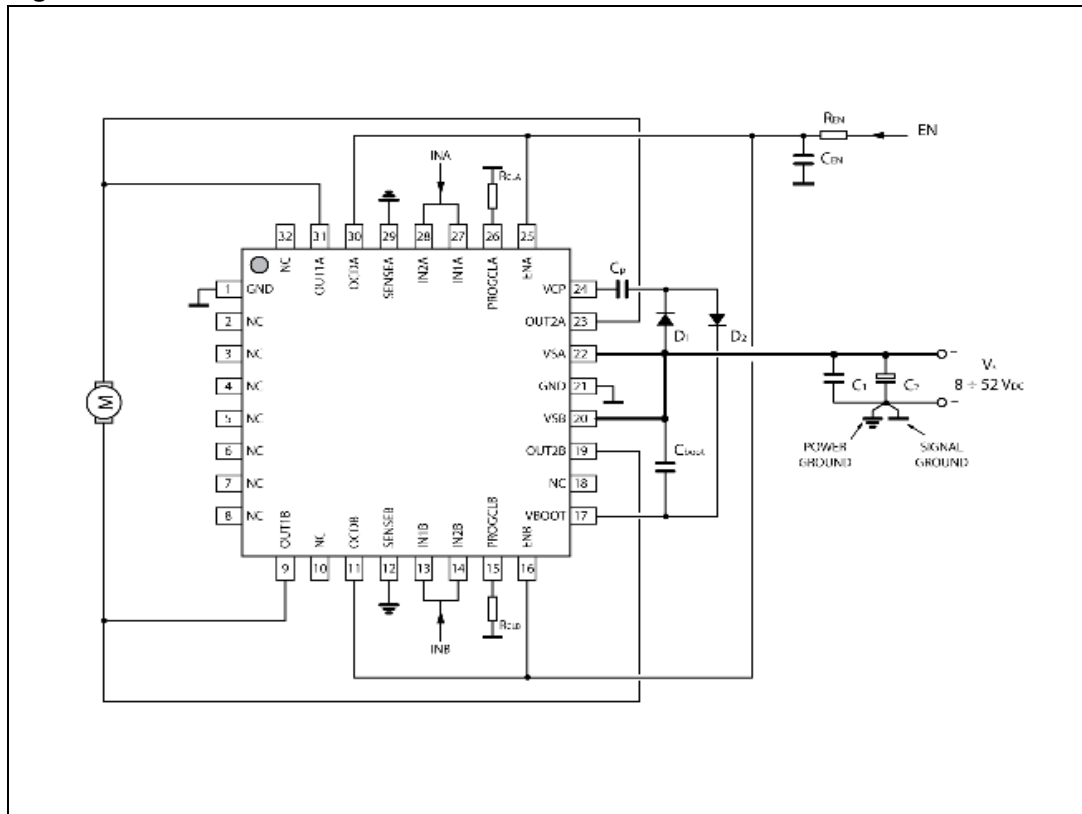

It is also possible to parallel the four half bridges to obtain a simple half bridge as shown in [Figure 17](#). In this configuration the, the over current threshold is equal to twice the minimum threshold set by the resistors  $R_{cLA}$  or  $R_{cLB}$  in [Figure 17](#). It is recommended to use  $R_{cLA} = R_{cLB}$ .

The resulting half bridge has the following characteristics.

- Equivalent device: half bridge
- $R_{DS(on)}$  0.18  $\Omega$  typ. value @  $T_J = 25^\circ C$
- 2.8 A max RMS load current
- 5.6 A max OCD threshold

Figure 17. Paralleling the four half bridges

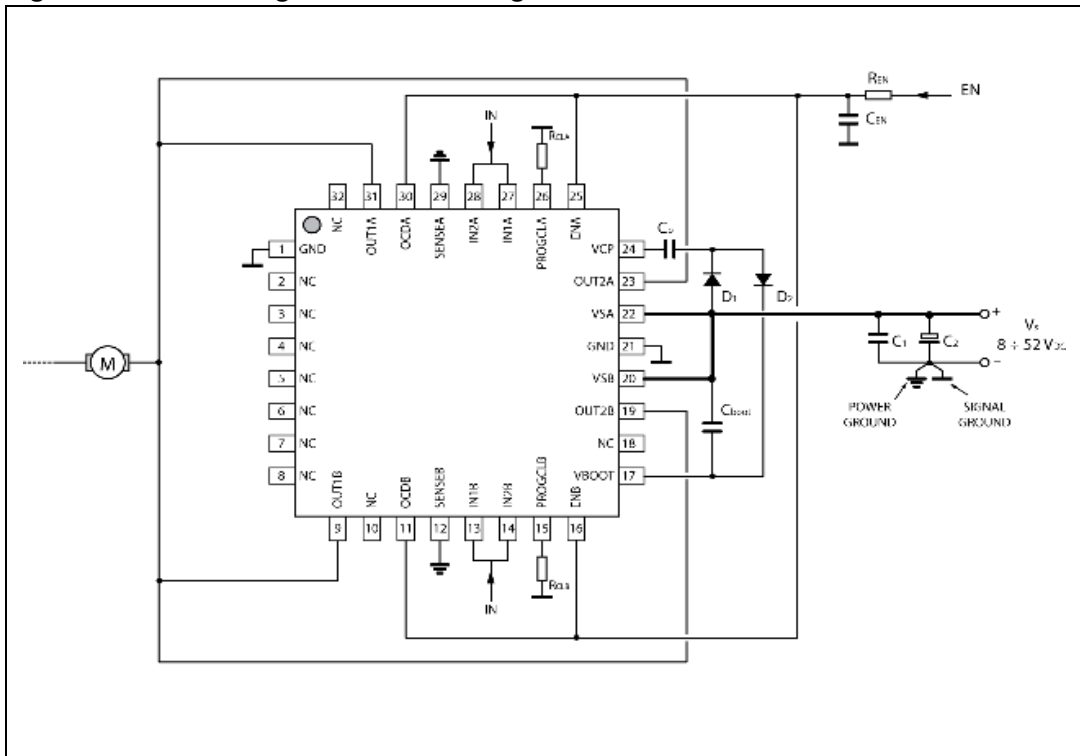

## 7 Output current capability and IC power dissipation

In [Figure 18](#) and [Figure 19](#) are shown the approximate relation between the output current and the IC power dissipation using PWM current control driving two loads, for two different driving types:

- One full bridge ON at a time ([Figure 18](#)) in which only one load at a time is energized.
- Two full bridges ON at the same time ([Figure 19](#)) in which two loads at the same time are energized.

For a given output current and driving type the power dissipated by the IC can be easily evaluated, in order to establish which package should be used and how large must be the on-board copper dissipating area to guarantee a safe operating junction temperature (125 °C maximum).

**Figure 18. IC power dissipation vs output current with one full bridge ON at a time**

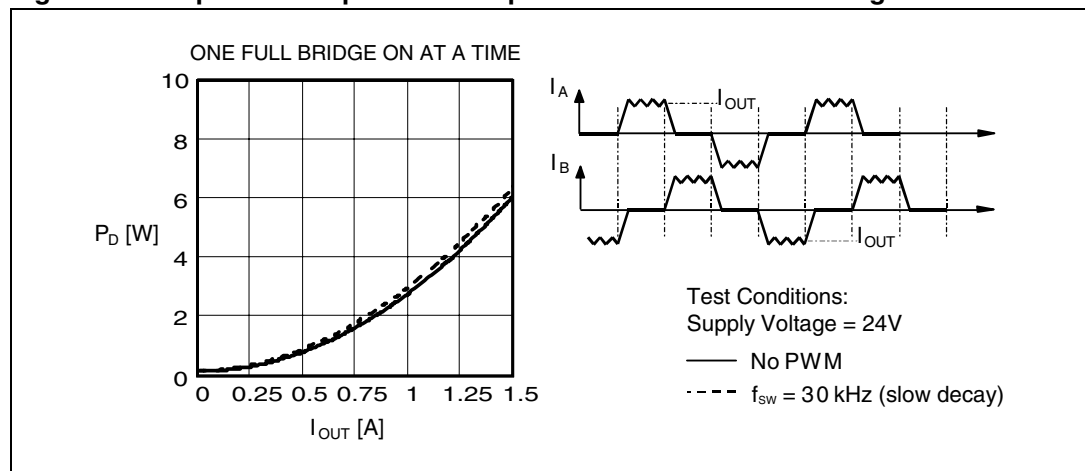

**Figure 19. IC power dissipation vs output current with two full bridges ON at the same time**

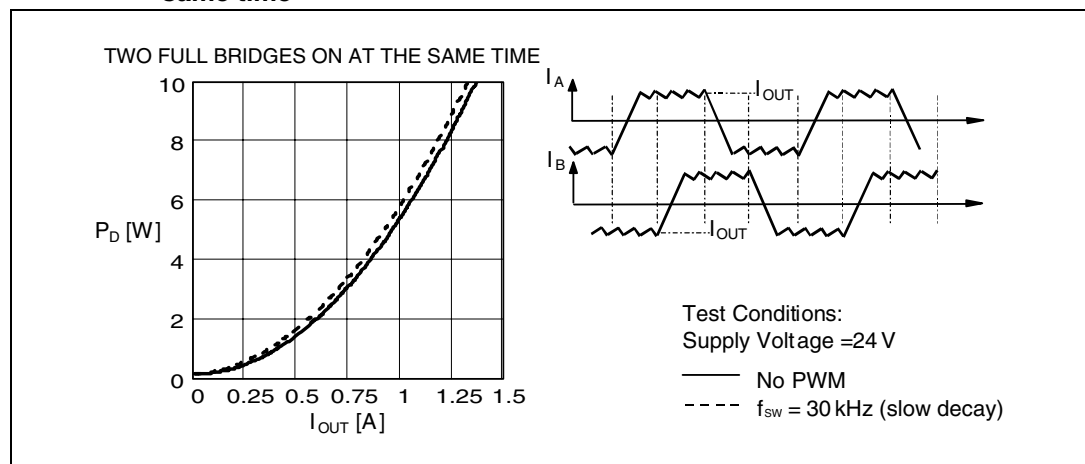

## 8 Thermal management

In most applications the power dissipation in the IC is the main factor that sets the maximum current that can be delivered by the device in a safe operating condition. Therefore, it has to be taken into account very carefully. Besides the available space on the PCB, the right package should be chosen considering the power dissipation. Heat sinking can be achieved using copper on the PCB with proper area and thickness. For instance, using a VFQFPN32L 5x5 package the typical  $R_{th(JA)}$  is about 42 °C/W when mounted on a double-layer FR4 PCB with a dissipating copper surface of 0.5 cm<sup>2</sup> on the top side plus 6 cm<sup>2</sup> ground layer connected through 18 via holes (9 below the IC).



## 9 Package mechanical data

In order to meet environmental requirements, ST offers these devices in different grades of ECOPACK® packages, depending on their level of environmental compliance. ECOPACK® specifications, grade definitions and product status are available at: [www.st.com](http://www.st.com). ECOPACK® is an ST trademark.

**Table 9. VFQFPN32 5x5x1.0 pitch 0.50**

Dim.	Databook (mm)		
	Min	Typ	Max
A	0.80	0.85	0.95
b	0.18	0.25	0.30
b1	0.165	0.175	0.185
D	4.85	5.00	5.15
D2	3.00	3.10	3.20
D3	1.10	1.20	1.30
E	4.85	5.00	5.15
E2	4.20	4.30	4.40
E3	0.60	0.70	0.80
e		0.50	
L	0.30	0.40	0.50
ddd			0.08

- Note:*
- 1 VFQFPN stands for thermally enhanced very thin profile fine pitch quad flat package no lead. Very thin profile:  $0.80 < A = 1.00$  mm.
  - 2 Details of terminal 1 are optional but must be located on the top surface of the package by using either a mold or marked features.

Figure 20. Package dimensions

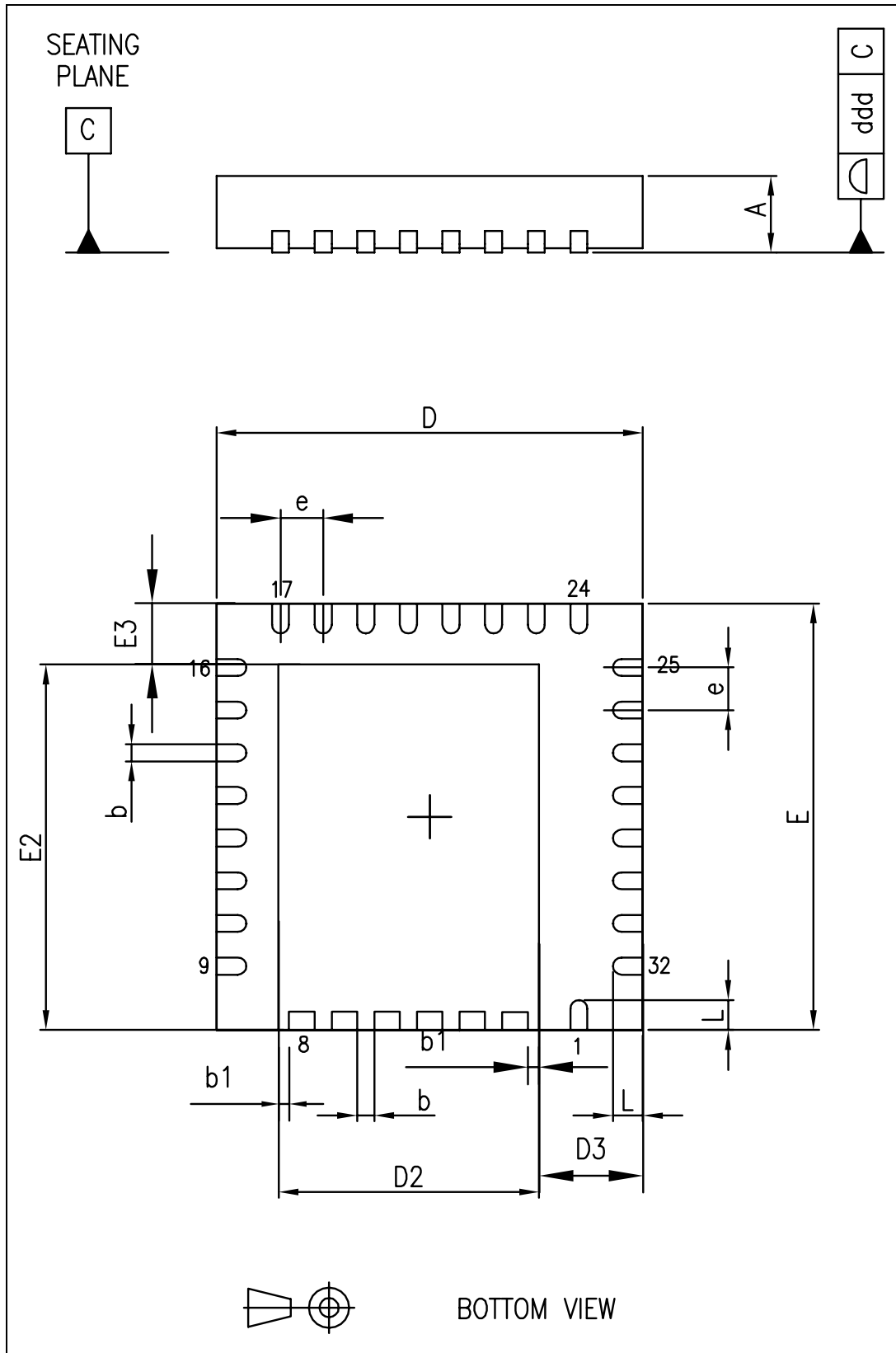

## 10 Order codes

Table 10. Order code

Order code	Package	Packaging
L6226Q	VFQFPN32 5x5x1.0	Tube
L6226QTR		Tape and reel

## 11 Revision history

**Table 11. Document revision history**

Date	Revision	Changes
18-Jan-2008	1	First release
10-Jun-2008	2	Updated: <i>Figure 14 on page 18, Figure 15 on page 20, Figure 16 on page 21 and Figure 17 on page 22</i> Added: <i>Note 1 on page 4</i>
28-Jan-2009	3	Updated value in <i>Table 3: Thermal data on page 4</i>
23-Sep-2009	4	Updated value in <i>Table 1: Absolute maximum ratings on page 3</i>
30-Aug-2010	5	Updated <i>Table 10</i>

**Please Read Carefully:**

Information in this document is provided solely in connection with ST products. STMicroelectronics NV and its subsidiaries ("ST") reserve the right to make changes, corrections, modifications or improvements, to this document, and the products and services described herein at any time, without notice.

All ST products are sold pursuant to ST's terms and conditions of sale.

Purchasers are solely responsible for the choice, selection and use of the ST products and services described herein, and ST assumes no liability whatsoever relating to the choice, selection or use of the ST products and services described herein.

No license, express or implied, by estoppel or otherwise, to any intellectual property rights is granted under this document. If any part of this document refers to any third party products or services it shall not be deemed a license grant by ST for the use of such third party products or services, or any intellectual property contained therein or considered as a warranty covering the use in any manner whatsoever of such third party products or services or any intellectual property contained therein.

**UNLESS OTHERWISE SET FORTH IN ST'S TERMS AND CONDITIONS OF SALE ST DISCLAIMS ANY EXPRESS OR IMPLIED WARRANTY WITH RESPECT TO THE USE AND/OR SALE OF ST PRODUCTS INCLUDING WITHOUT LIMITATION IMPLIED WARRANTIES OF MERCHANTABILITY, FITNESS FOR A PARTICULAR PURPOSE (AND THEIR EQUIVALENTS UNDER THE LAWS OF ANY JURISDICTION), OR INFRINGEMENT OF ANY PATENT, COPYRIGHT OR OTHER INTELLECTUAL PROPERTY RIGHT.**

**UNLESS EXPRESSLY APPROVED IN WRITING BY AN AUTHORIZED ST REPRESENTATIVE, ST PRODUCTS ARE NOT RECOMMENDED, AUTHORIZED OR WARRANTED FOR USE IN MILITARY, AIR CRAFT, SPACE, LIFE SAVING, OR LIFE SUSTAINING APPLICATIONS, NOR IN PRODUCTS OR SYSTEMS WHERE FAILURE OR MALFUNCTION MAY RESULT IN PERSONAL INJURY, DEATH, OR SEVERE PROPERTY OR ENVIRONMENTAL DAMAGE. ST PRODUCTS WHICH ARE NOT SPECIFIED AS "AUTOMOTIVE GRADE" MAY ONLY BE USED IN AUTOMOTIVE APPLICATIONS AT USER'S OWN RISK.**

Resale of ST products with provisions different from the statements and/or technical features set forth in this document shall immediately void any warranty granted by ST for the ST product or service described herein and shall not create or extend in any manner whatsoever, any liability of ST.

ST and the ST logo are trademarks or registered trademarks of ST in various countries.

Information in this document supersedes and replaces all information previously supplied.

The ST logo is a registered trademark of STMicroelectronics. All other names are the property of their respective owners.

© 2010 STMicroelectronics - All rights reserved

STMicroelectronics group of companies

Australia - Belgium - Brazil - Canada - China - Czech Republic - Finland - France - Germany - Hong Kong - India - Israel - Italy - Japan - Malaysia - Malta - Morocco - Philippines - Singapore - Spain - Sweden - Switzerland - United Kingdom - United States of America

[www.st.com](http://www.st.com)