

QUICK START GUIDE FOR DEMONSTRATION CIRCUIT 509

DUAL PHASE, SINGLE OUTPUT SYNCHRONOUS BUCK CONVERTER

LTC3729EUH

DESCRIPTION

Demonstration circuit 509 is a single output step down converter featuring the LTC3729EUH. The LTC3729EUH is a dual phase controller with a frequency range of 250kHz to 550kHz in a 32 lead 5mm × 5mm QFN package. The QFN package has an exposed bottom pad that is soldered to the PCB and provides the LTC3729EUH with low thermal impedance. The input voltage range of the DC509 is 5V to 14V and the output voltage is 2.5V with a load rating of 25A.

The DC509A also contains a footprint for a 5.5V boost converter bias supply whose output is connected to EXTVCC. See the “Optional Bias Supply” section below for more details.

Design files for this circuit board are available. Call the LTC factory.

Table 1. Performance Summary

PARAMETER	CONDITION	VALUE
Minimum Input Voltage		5V
Maximum Input Voltage		14V
V _{OUT}	V _{IN} = 5V to 14V, I _{OUT} = 0A to 25A	2.5V ± 3%

QUICK START PROCEDURE

Demonstration circuit 509 is easy to set up to evaluate the performance of the LTC3729EUH. Refer to Figure 1 for proper measurement equipment setup and follow the procedure below:

1. With power off, connect the input voltage source and the load. The input cables should be sized to carry current of at least 15A. The load cables need to be sized for at least 30A.
2. The jumpers should be placed in their default positions as shown in Figure 1.
3. If a constant current electronic load is used, preset the load current to about 1A or less before applying power to the input. Otherwise, the foldback current limit function of the LTC3729 will be triggered during startup and the converter will remain in current limit during steady-state operation.
4. Apply power to the input and set the input voltage to 12V. The output voltage should be 2.5V ± 3%. Increase the load to 25A. The output voltage should still be within regulation.
5. Keep the input voltage at 12.0V and the load at 25A. Measure the DC input current. It should be less than 6.1A.
6. Adjust the input voltage and load current to the desired levels within their limits and observe the regulation, output ripple, load step response, efficiency and other parameters.
7. If desired, the switching frequency of the converter may be adjusted with jumper JP1. The default position is 550kHz and the other position is 250kHz. “550kHz” is a slight misnomer; the actual PLLFLTR signal will be 1.8V and this will result in a typical switching frequency of roughly 500kHz. A typical switching frequency of 550kHz can be achieved by decreasing the value of R3 while in the 550kHz position. By placing the jumper in the 250kHz position, the PLLFLTR signal will be tied to ground. The typical switching frequency will then be 250kHz.
8. The phasing between controller #1 and CLKOUT and between controller #1 and #2 can be set with jumper JP2. The default position is 90, which will result in a

QUICK START GUIDE FOR DEMONSTRATION CIRCUIT 509

DUAL PHASE, SINGLE OUTPUT SYNCHRONOUS BUCK CONVERTER

90° phase shift between the CLKOUT signal and controller #1 and 180° phase shift between controllers #1 and #2. Refer to the LTC3729 data sheet for more details.

NOTE: When measuring the output voltage ripple, care must be taken to avoid a long ground lead on the oscilloscope probe. Make the connections as short as

possible and measure the output ripple directly across output capacitor C20 or C21. See Figure 2.

NOTE: For input voltages from 5V to 7V, connect the input voltage to EXT VCC. Otherwise, the INT VCC voltage will fall out of regulation and the operation of the circuit may be affected.

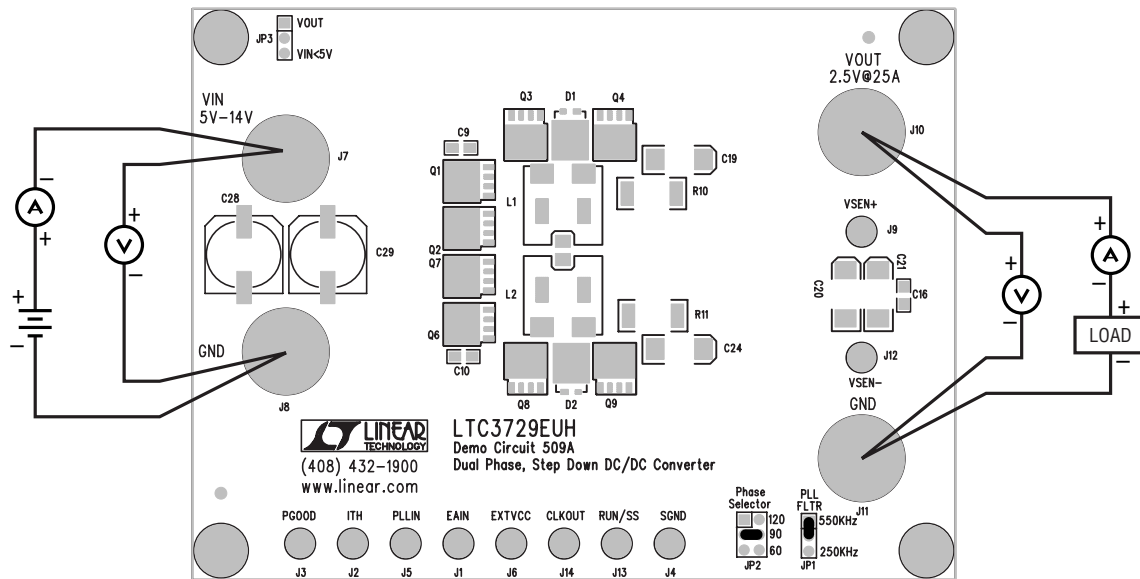

Figure 1. Proper Setup for Measurement Equipment

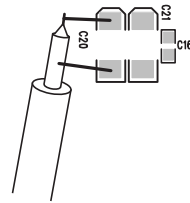

Figure 2. Measuring Output Ripple

OPTIONAL BIAS SUPPLY

The DC509A also contains a footprint for a 5.5V boost converter bias supply whose output is connected to EXTVCC. The input of this bias supply can be connected either to VIN, if $V_{IN} < 5V$, or to VOUT for $5V \leq V_{IN} \leq 14V$. The latter connection will provide higher efficiency. If this bias supply is stuffed, please keep the following points in mind:

1. The minimum input voltage for the optional bias supply is 3.0V using the LT1613. If the input voltage is less than 3.0V, the bias supply output may fall out of regulation. This means that the bias supply input cannot be connected to the main output if it is at the nominal 2.5V.
2. If the input voltage of the optional bias supply is connected to VIN, then the board will need to be slightly modified to ensure that EXTVCC does not exceed V_{IN} . These are the modifications:
 - a. Remove resistor R12.
 - b. Tie the (+) end of C14 to the (+) end of C15.
3. If the input voltage of the optional bias supply is connected to VOUT, precautions need to be taken to

make sure that EXTVCC does not exceed VIN during turn-on of the main converter. Follow these steps when turning on the main converter:

- a. Preset the load current to 1A or less.
 - b. Tie the RUN/SS pin to ground.
 - c. Turn-on the main input voltage and set to desired level.
 - d. Disconnect the RUN/SS pin from ground.
 - e. Apply the desired load to the output.
4. If a different power MOSFET configuration is used or the switching frequency is increased, then be sure to measure the current flowing into the EXTVCC pin and make sure the current will not exceed the maximum output current of the bias supply. At 3.3V input, the maximum output current of the bias supply is 200mA.

For further assistance, contact the factory.

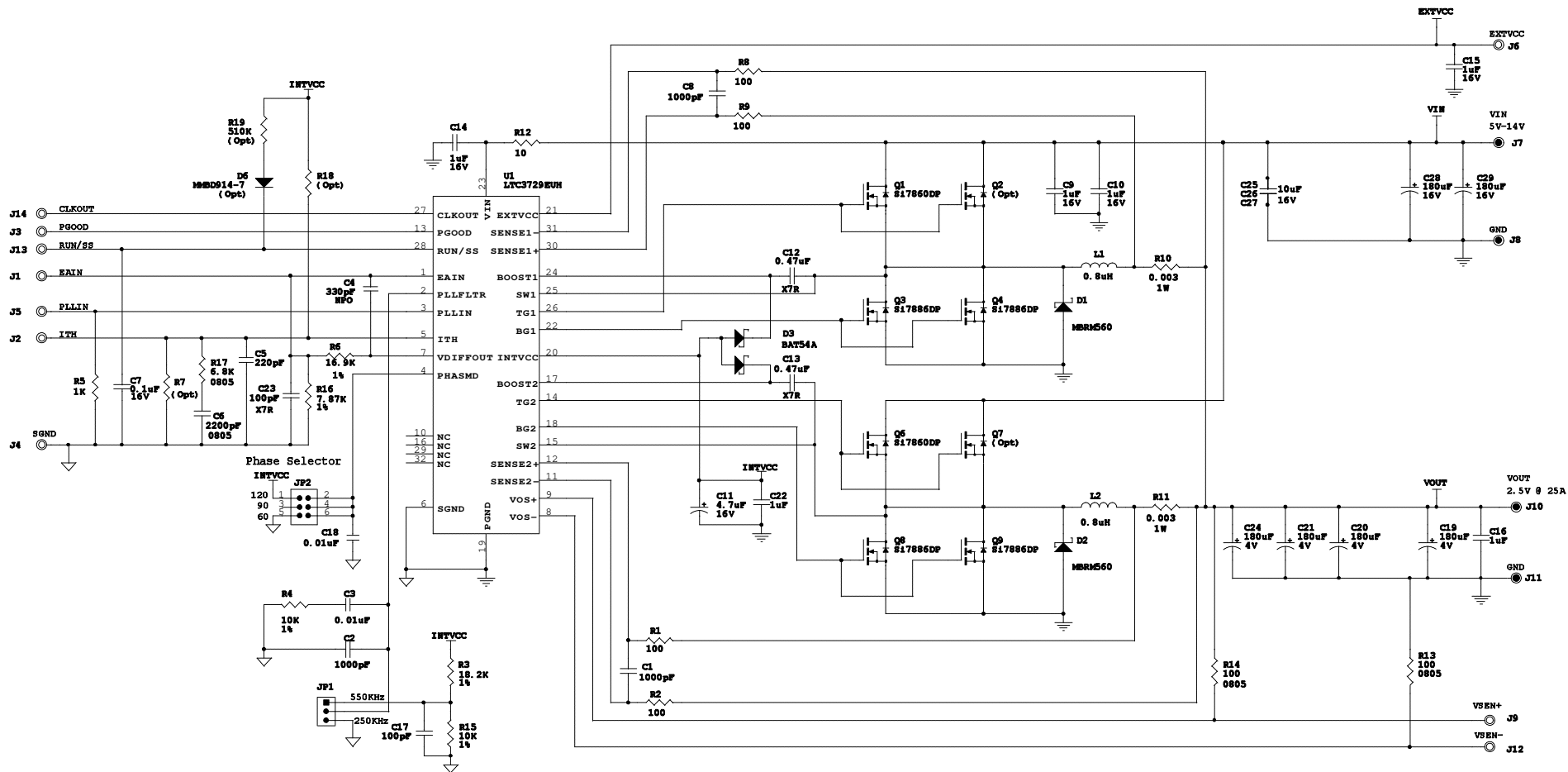

Optional Bias Circuit(DO NOT STUFF)

