

© 1967 BY AMP INCORPORATED. ALL RIGHTS RESERVED. AMP PRODUCTS COVERED BY PATENTS AND/OR PATENTS PENDING. APPROVED PER GOVT CONTRACT NO.

LOCATION FOR AMP-TAB FEMALE CONTACT

(1)-582589-1.1. SAME AS -1 EXCEPT TO HAVE CAVITY IDENTIFICATION ON TOP SURFACE OF HOUSING.

CAVITY IDENTIFICATION ON P/N (1)-582589-1 ONLY.

REVISIONS				
ZONE	LTR	DESCRIPTION	DATE	APPROVED
✓	Y	ECO-08-020973	PY 11-08	JW

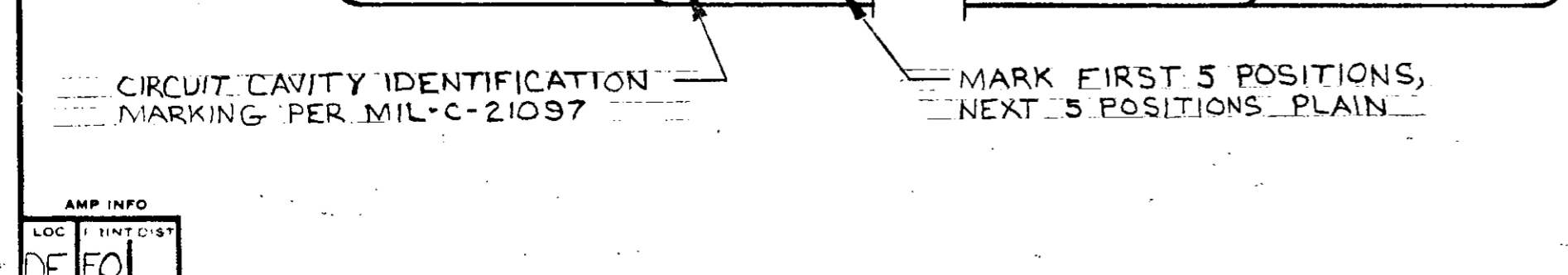
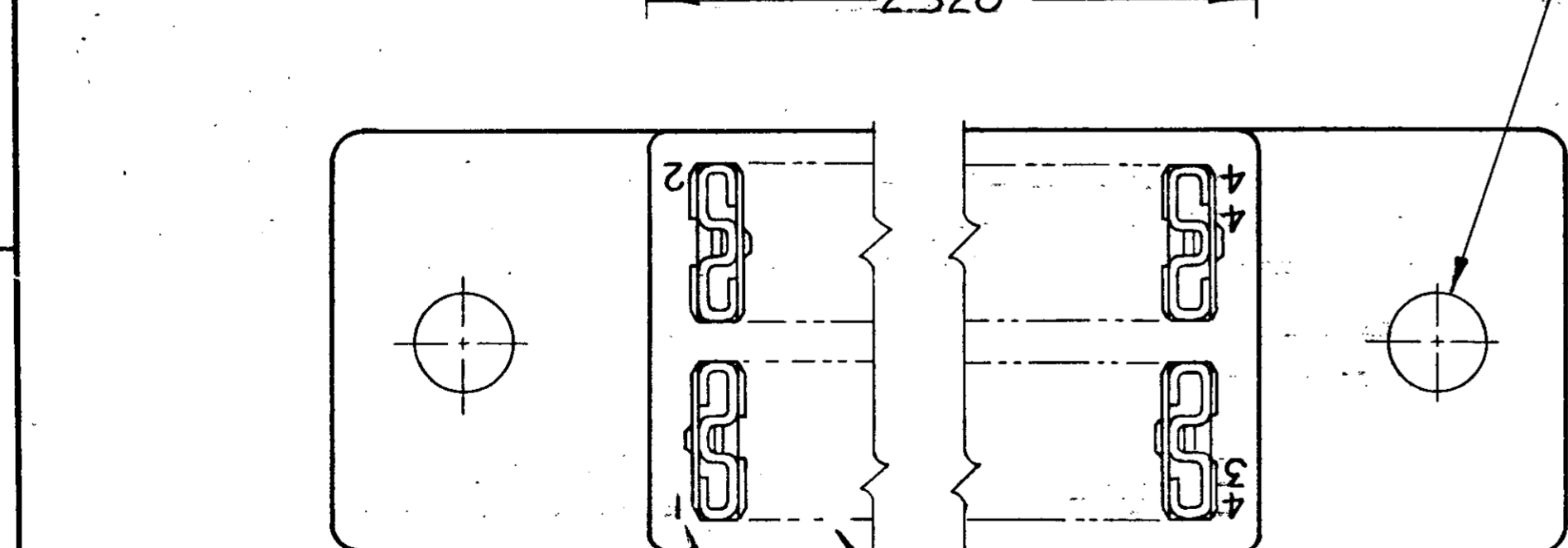
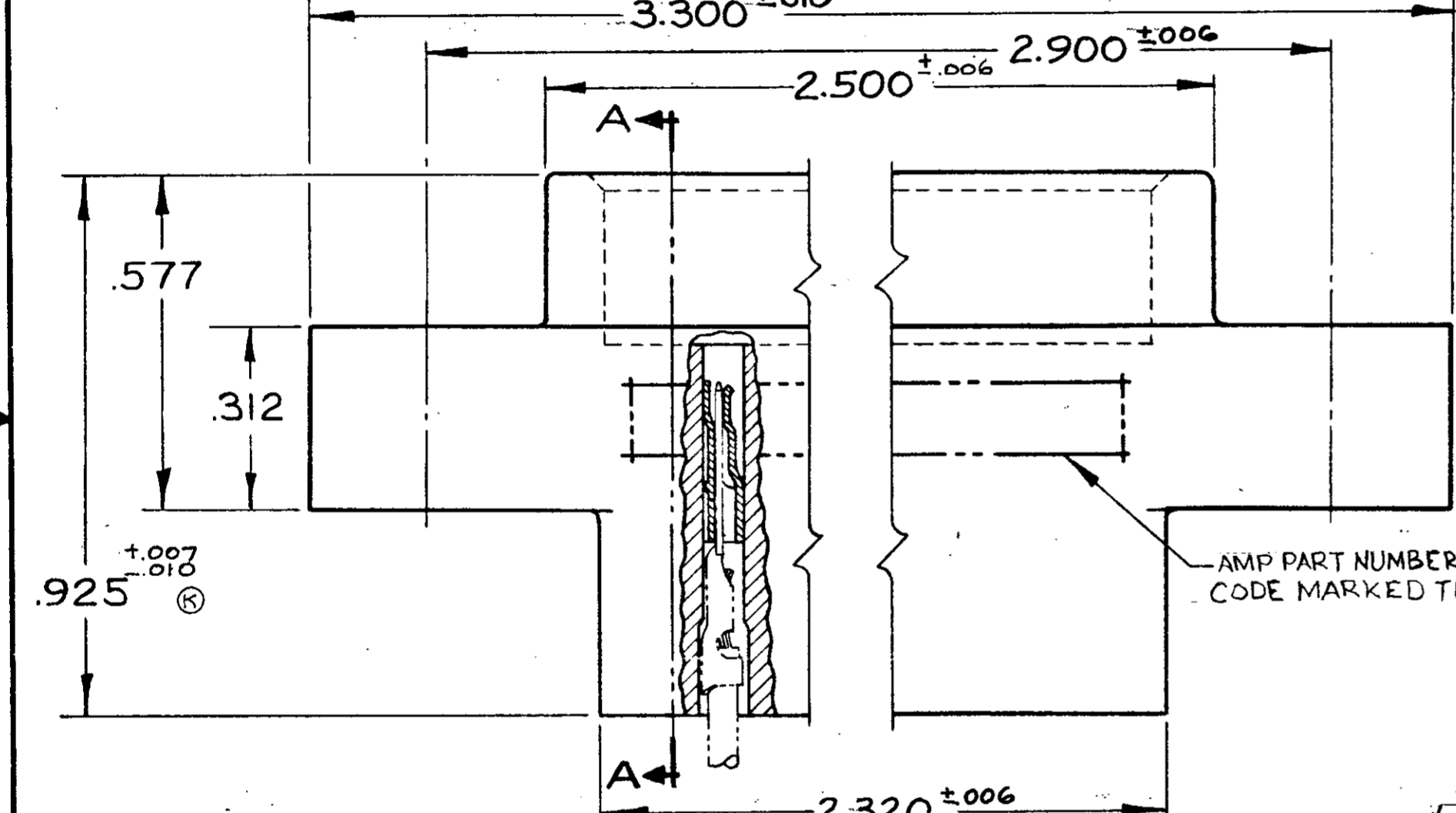
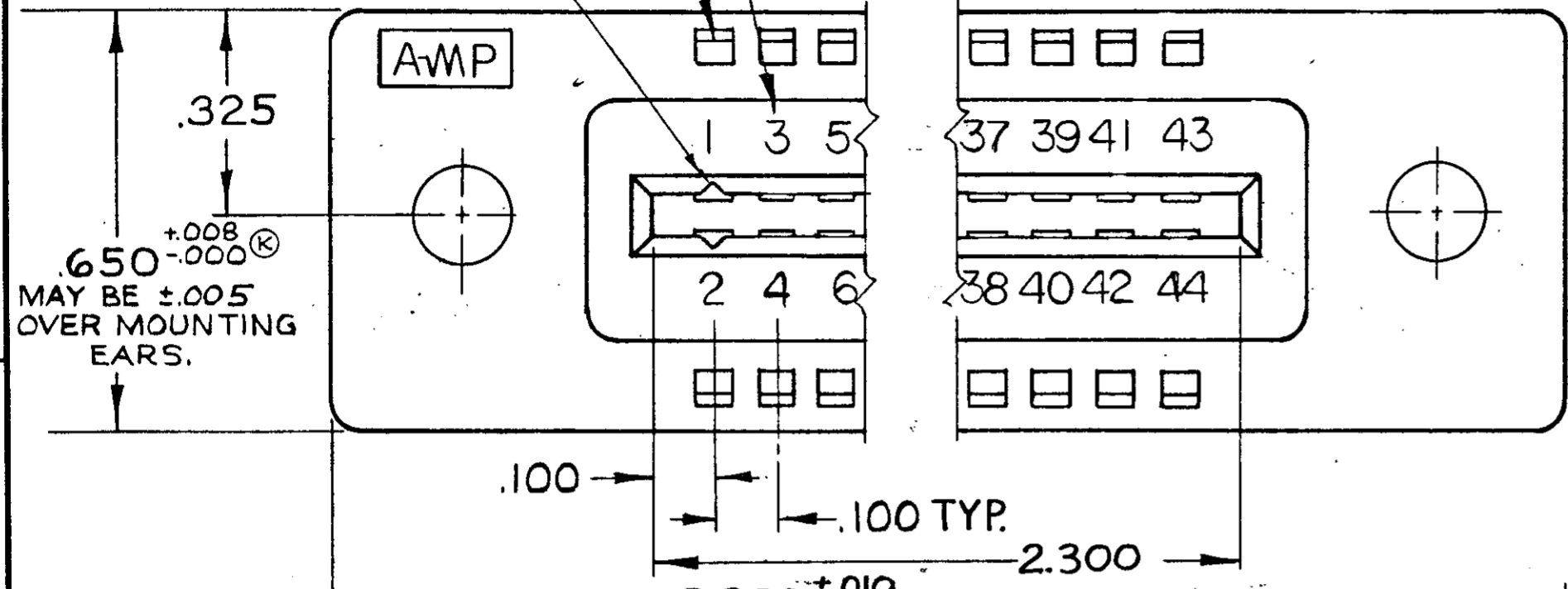

3. LASER MARKING ACCEPTABLE FOR ALL MARKING  
 △ GROOVES FOR "ON CONTACT KEYING" AMP'S OPTION DEPENDING ON METHOD OF MANUFACTURE. FOR "ON CONTACT" KEYING USE KEYING PLUG P/N 583487-1. (MUST BE ORDERED SEPARATELY.)  
 △ MOUNTING EAR CONFIGURATION AMP'S OPTION DEPENDS ON METHOD OF MANUFACTURE.

- 582589-1.1 AS SHOWN "J" DIA HOLES = .128
- OBS 582589-2.1 SAME AS -1 EXCEPT "J" DIA HOLES = .156
- OBS 582589-6 SAME AS 4 EXCEPT INK STAMPING ON TOP AND BOTTOM
- OBSOLETE 582589-4.1 SAME AS -1 EXCEPT: 2. FLOATING BUSHINGS
- OBS 582589-5.1 SAME AS 4 EXCEPT: FLOATING BUSHINGS REVERSED

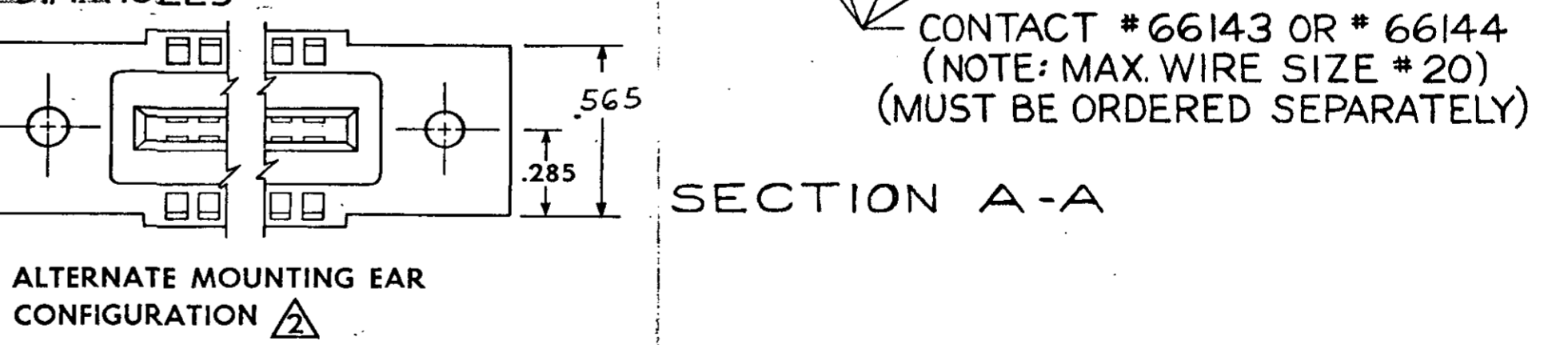
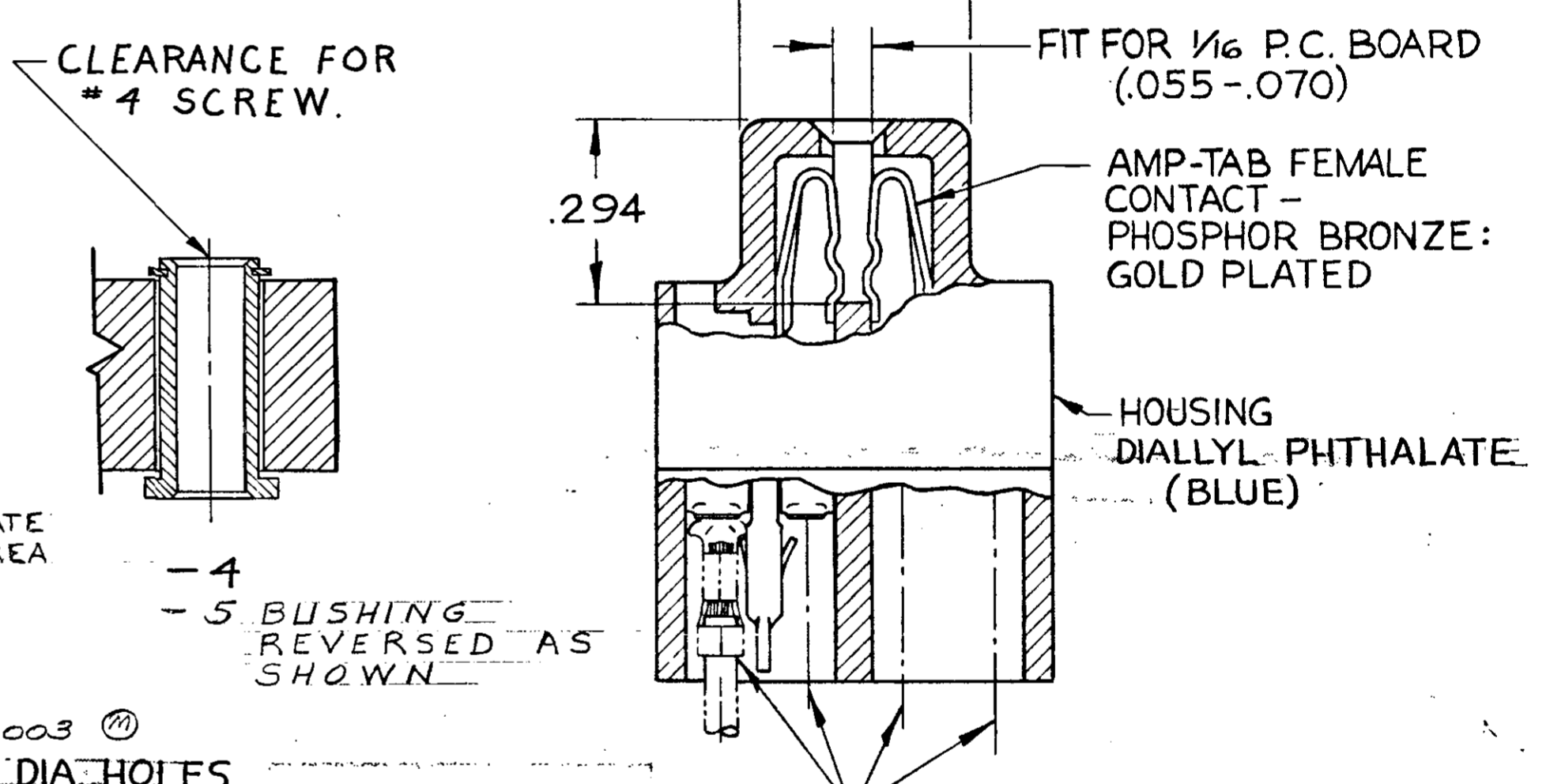

UNLESS OTHERWISE SPECIFIED DIMENSIONS ARE IN INCHES TOLERANCES ON		CONTRACT NO.		AMP INCORPORATED HARRISBURG, PENNSYLVANIA	
FRACTIONS	DECIMALS	ANGLES	DR	DATE	NAME
±	±.005	±	<i>J. Asch</i>	12-16-66	22 POSITION AMP-TAB CONNECTOR .100 CENTERS QUAD
MATERIAL	HEAT TREAT	FINISH	CHK	DATE	SIZE
SEE CALLOUT	—	SEE CALLOUT	<i>W. Burns</i>	1-5-67	C
			DSGN ENGR	DATE	CODE IDENT NO
			<i>J. Kaufman</i>	1-10-67	00779
			APPD	DATE	NUMBER
			<i>R. Showman</i>	1/10/67	582589
			OTHER APPD		REV
					Y
SCALE 4-1		WT		CALC	
				ACTUAL	
				SHEET	