

XBee Grove Development Board

The XBee Grove Development Board is a simple-to-use base unit. You can use it to evaluate XBee modules, as it connects any XBee/XBee-PRO module to a PC or microcontroller. One of the main features of the board is that it has several Grove connectors where you can plug in a Grove Module. You can learn more about the [Grove module](#) on the Seed Studio wiki.

There are two variants of the board: THT and SMT.

This guide includes the following topics:

- [Overview](#)

XBee THT Grove Development Board

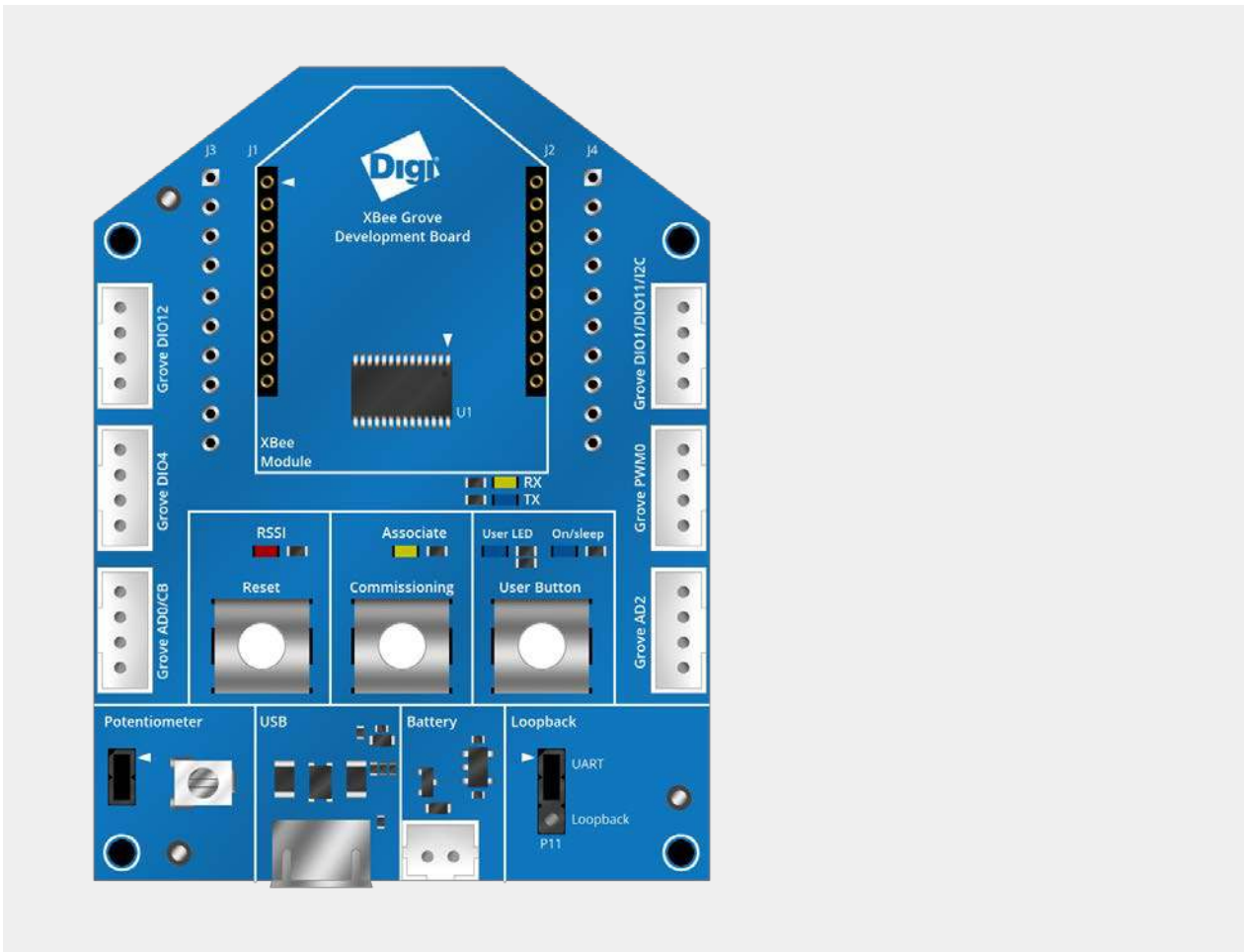

XBee SMT Grove Development Board

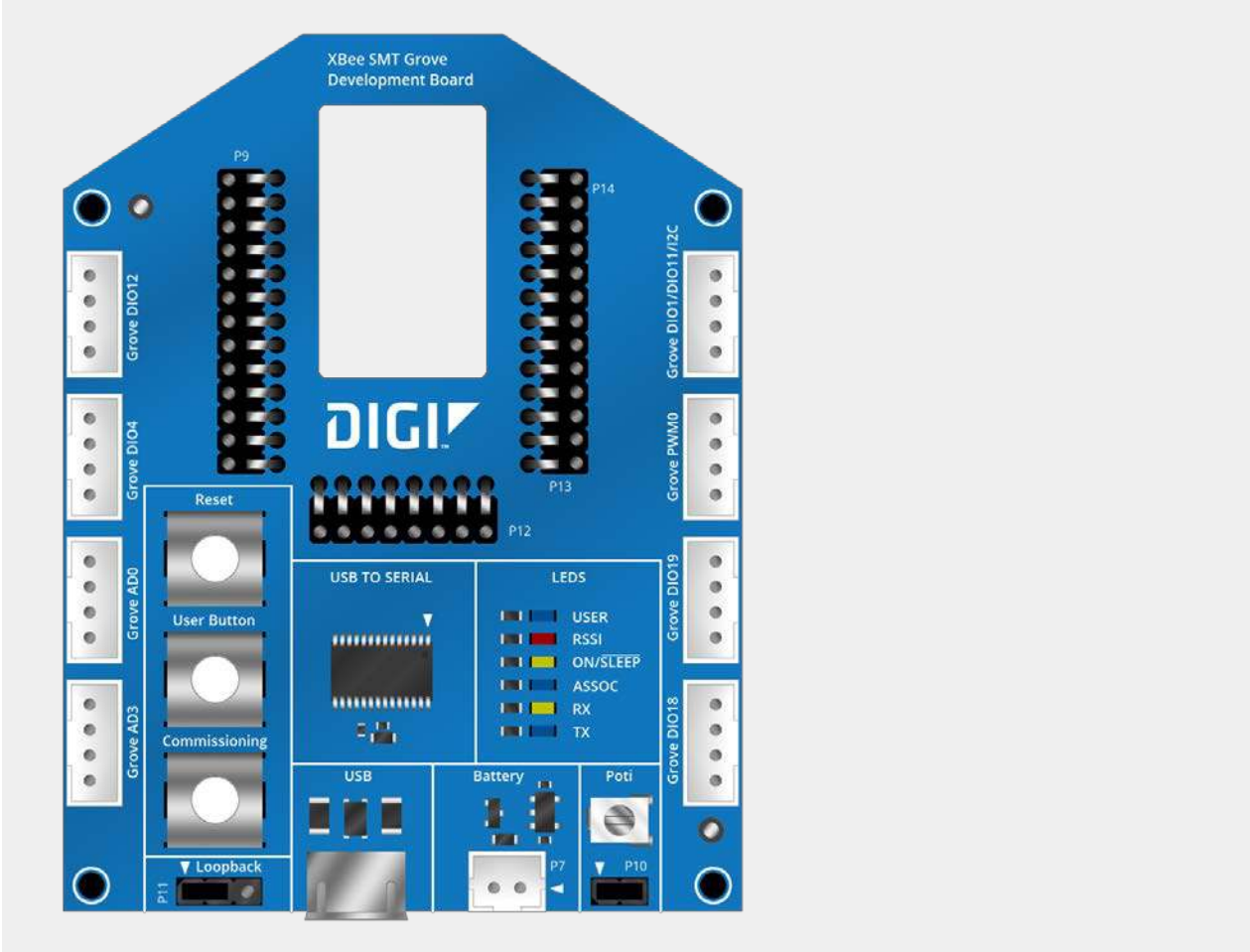

Overview

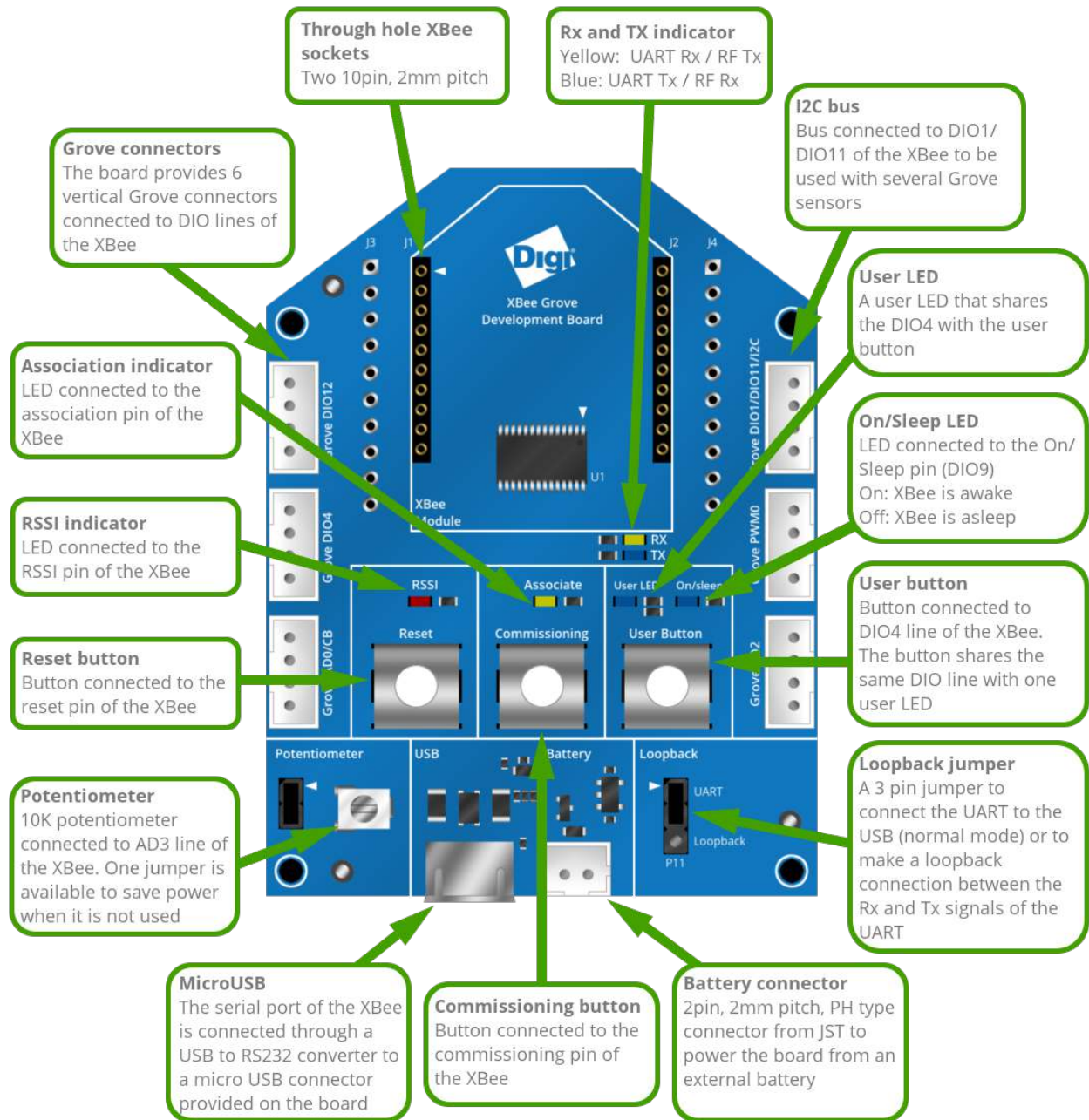

On this page:

- [Mechanical](#)
- [Power supply](#)
- [XBee connector](#)
- [USB](#)
- [Reset button](#)

- [Commissioning button](#)
- [Association LED](#)
- [RSSI LED](#)
- [User LED and User button](#)
- [On/Sleep LED](#)
- [Potentiometer](#)
- [I2C](#)
- [Grove connectors](#)
- [Loopback jumper](#)

Mechanical

The XBee Grove Development Board is 44.8mm x 66mm with a shape similar to a regular XBee module.

The board provides four 3.2 mm assemble drills.

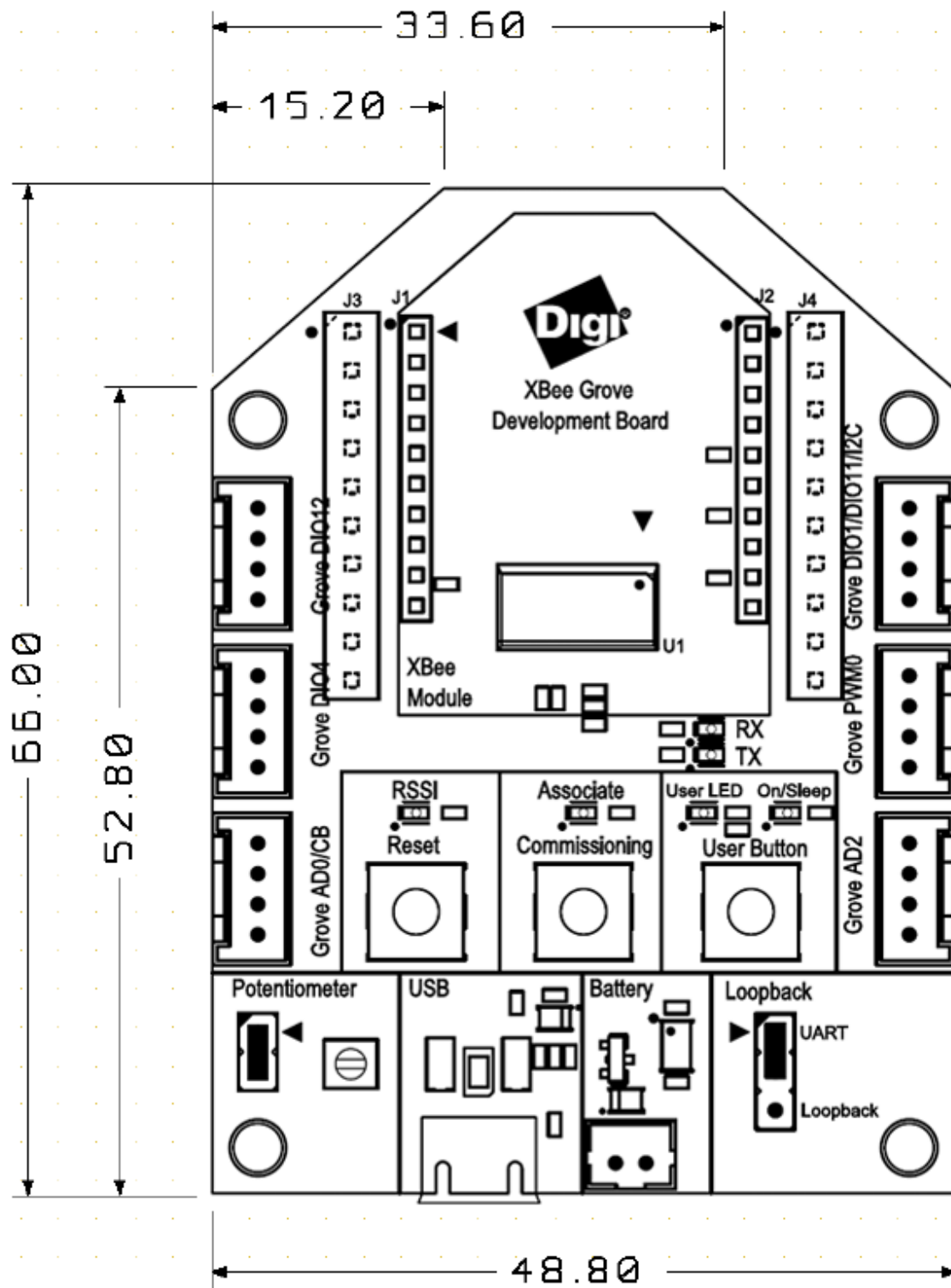

Power supply

The XBee Grove Development Board can be powered from the 5V supply available on the USB connector or from an external battery connected to a 2-pin, 2mm pitch, PH type connector from JST. When both supplies are available, the board is powered from the USB.

The board has a 3.3V regulator that generates 500mA supply.

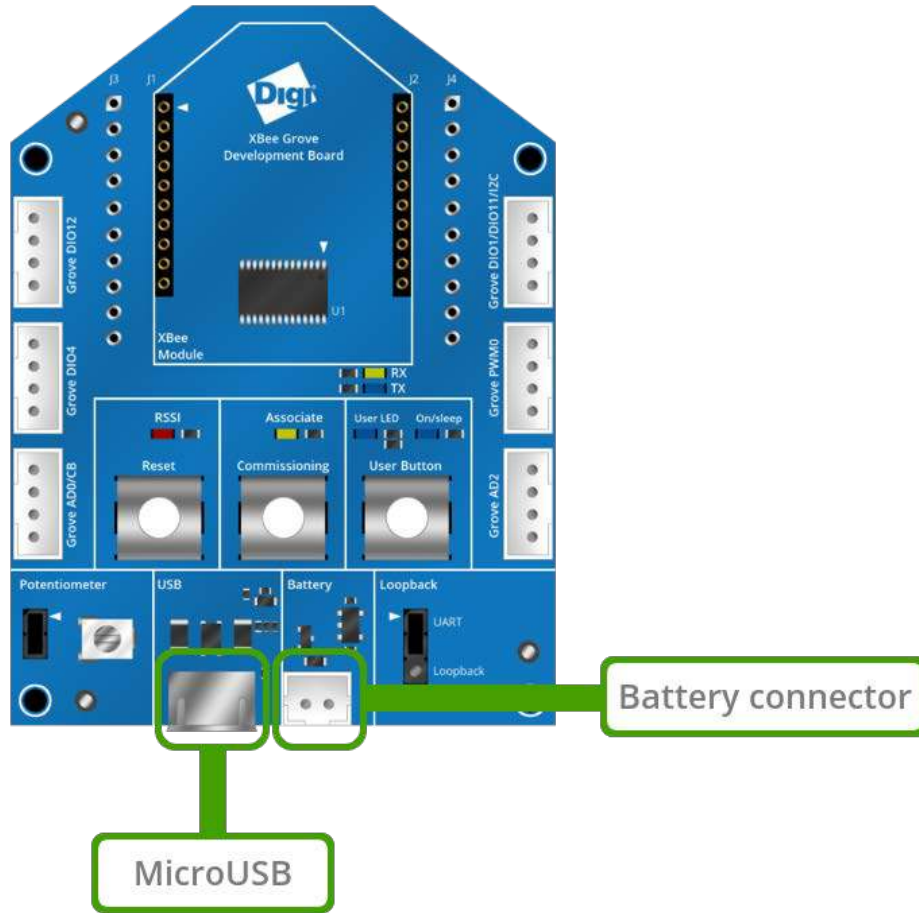

The following table shows the pinout of the battery connector:

Battery connector	Signal	Comments
1	VBAT	Battery supply input
2	GND	

XBee connector

The XBee Grove Development Board provides two 10-pin, THT, 2mm pitch sockets to connect a THT XBee module. It is compatible with both regular XBee/XBee-PRO and programmable XBee.

Footprints for two 10-pin, THT, 2.54mm pitch connectors are available on the board. These footprints can be used to solder a pin header on the top or bottom to access the XBee signals or to connect the XBee Grove Development Board to a bread board.

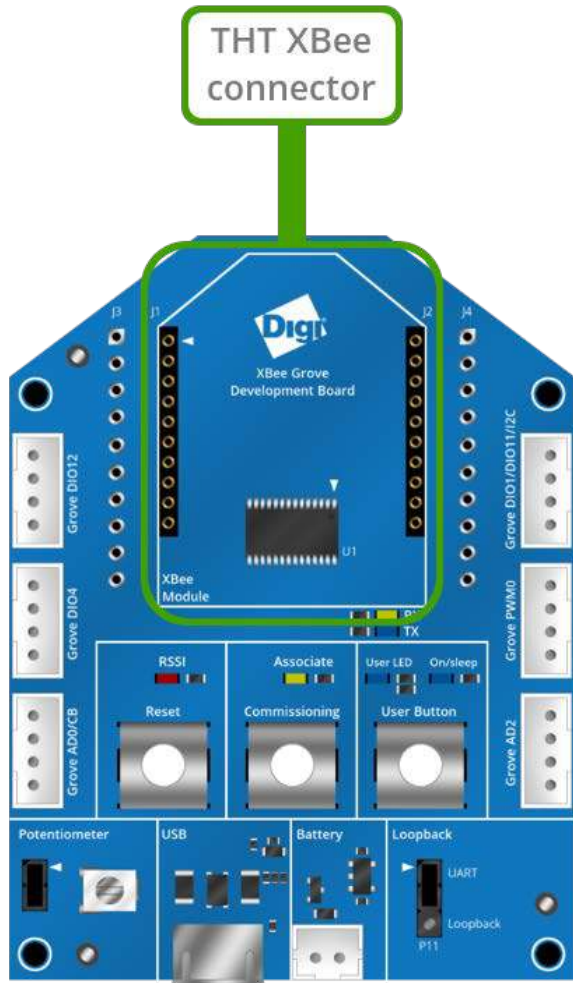

The following table shows the pinout of the XBee connector:

LEFT			RIGHT		
Pin	Signal	Comments	Pin	Signal	Comments
1	3.3V	XBee supply	1	DIO4	To GROVE_DIO4 and user LED/button
2	XBEE_TX	To serial to USB device	2	XBEE_CTS_N	To serial to USB device
3	XBEE_RX	To serial to USB device	3	DIO9	To On/Sleep LED
4	DIO12	To GROVE_DIO12	4	VREF	
5	RESET_N	To reset button	5	ASSOC_LED	To association LED
6	RSSI/PWM0	To RSSI LED and GROVE_PWM	6	XBEE_RTS_N	To serial to USB device

7	DIO11/I2C_SDA	To GROVE_I2C	7	AD3	To potentiometer
8	XBEE_PIN8	Connected to breadboard header	8	AD2	To GROVE_AD2
9	XBEE_DTR_N	To serial to USB device	9	DIO1/ISC_SCL	To GROVE_I2C
10	GND		10	AD0/CB	To commissioning button and GROVE_AD0

USB

The XBee Grove Development Board includes a microUSB connector and an FT232RL USB to RS232 converter to communicate with the serial port of the XBee.

A green LED and a yellow LED show the status of the TX and RX lines.

The hardware flow control signals of the XBee (XBee_RTS and XBee_CTS) are connected to the FT232RL device. Two serial 0R resistors disconnect the flow control of the chip if this functionality is not needed.

The XBEE_DTR_N signal is also connected to the FT232 chip. XCTU uses this signal to enter in the boot loader and will recover the module from incorrect firmware. A configurable 0R resistor disconnects this signal if the functionality is not needed.

A three-pin jumper configures the serial port in a loop back mode, connecting the RX and TX lines together. When positions 1-2 are closed, the serial port is configured in normal mode. In this mode, the serial port of the XBee is connected to the microUSB connector. If positions 2-3 are closed, the serial port will work in loopback mode. In this mode, the data transmitted by the XBee will be connected to the RX pin.

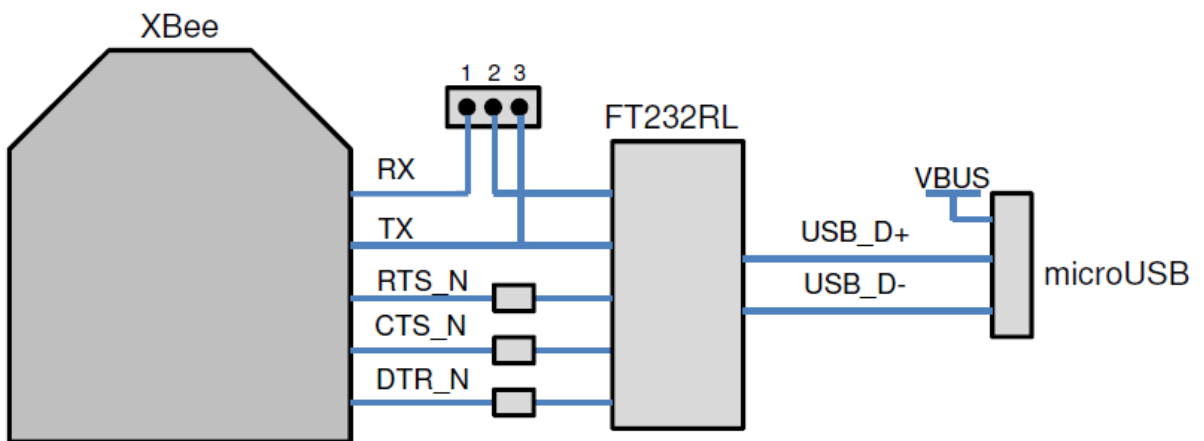
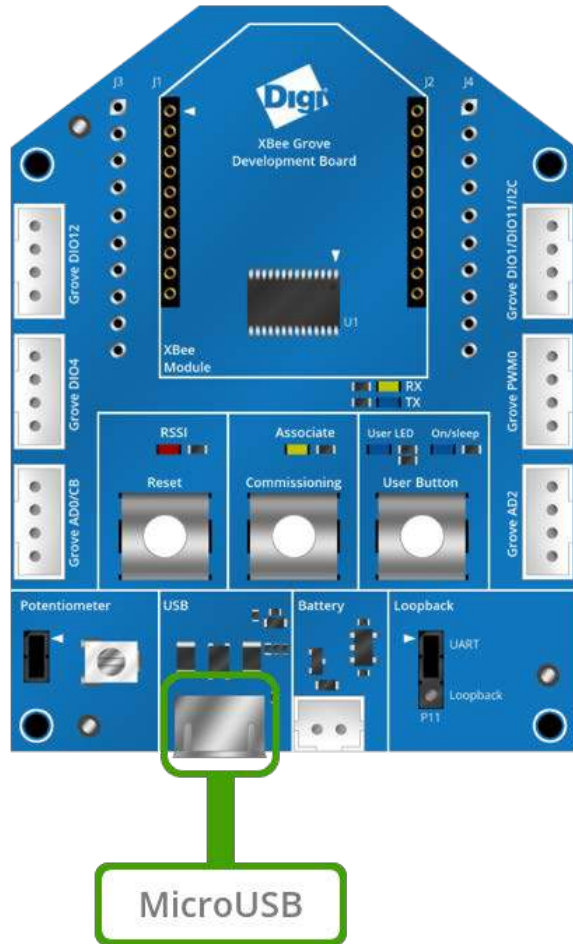

The USB connector is also used to power the board through the VBUS line.

Reset button

The XBee Grove Development Board has a reset button to reboot the XBee module.

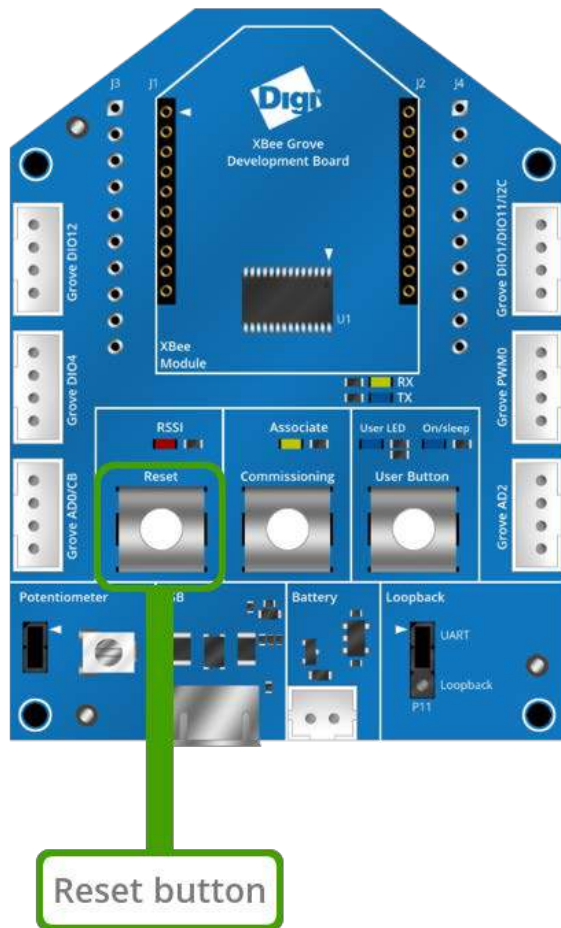

Commissioning button

The XBee Grove Development Board has a push button connected to the commissioning pin of the XBee module. The commissioning pin of the XBee is also connected to the Grove AD0 connector. You can use the commissioning push button in ZigBee or DigiMesh to aid in deploying devices in a network.

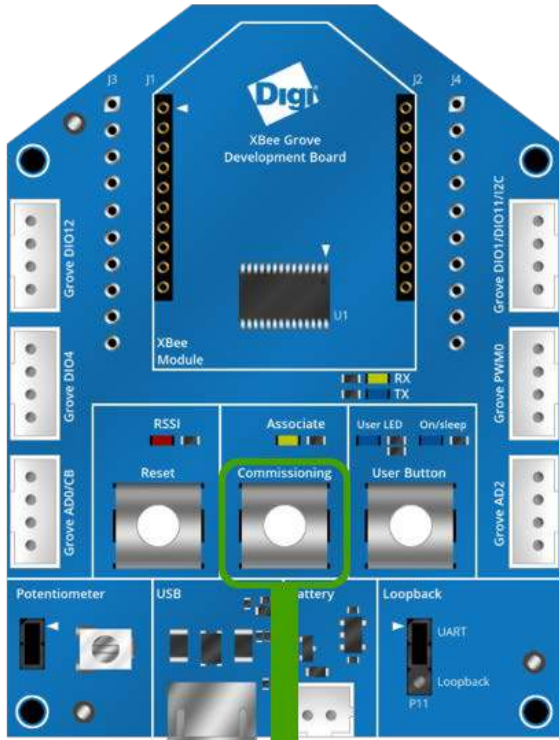

Commissioning button

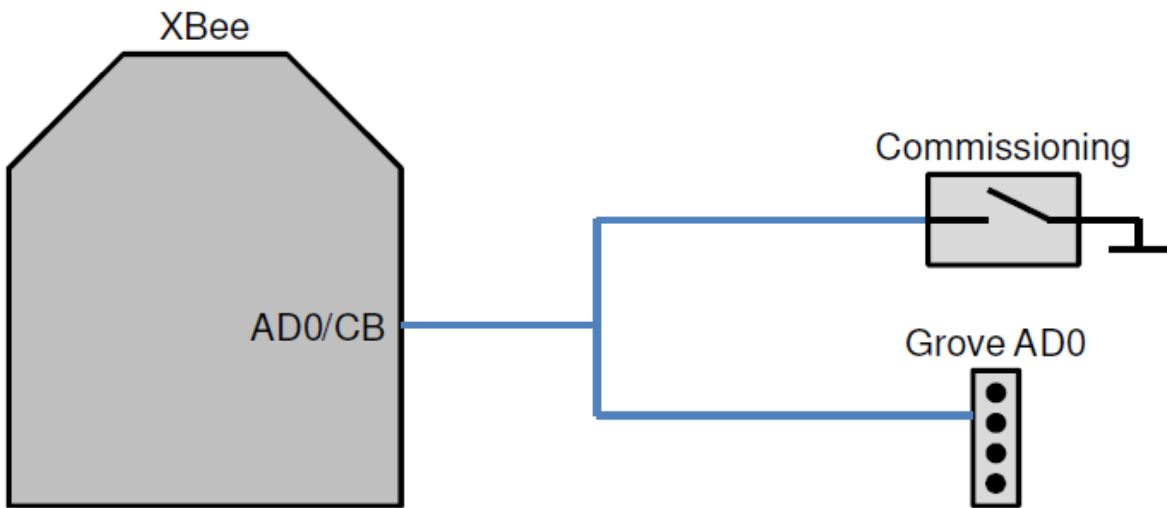

Association LED

The XBee Grove Development Board provides an LED connected to the association pin of the XBee module.

For more information about association, read the [XBee Product Manual](#).

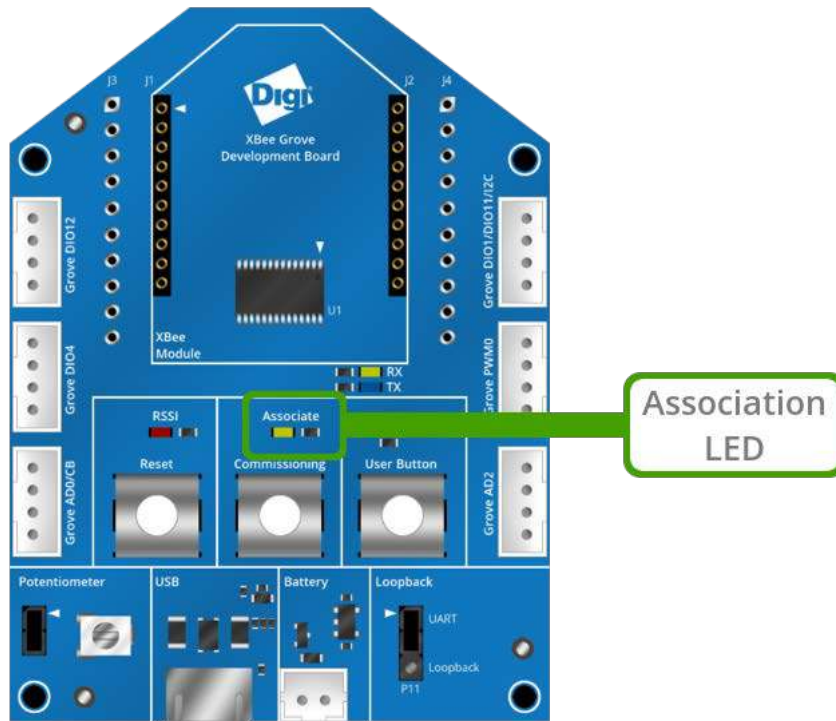

RSSI LED

The XBee Grove Development Board provides an LED connected to the RSSI/PWM0 pin of the XBee module. The RSSI/PWM signal is also connected to the PWM Grove connector.

If the PWM0 pin (P0) is configured as RSSI, the brightness of this LED will display the signal strength of the last packet received.

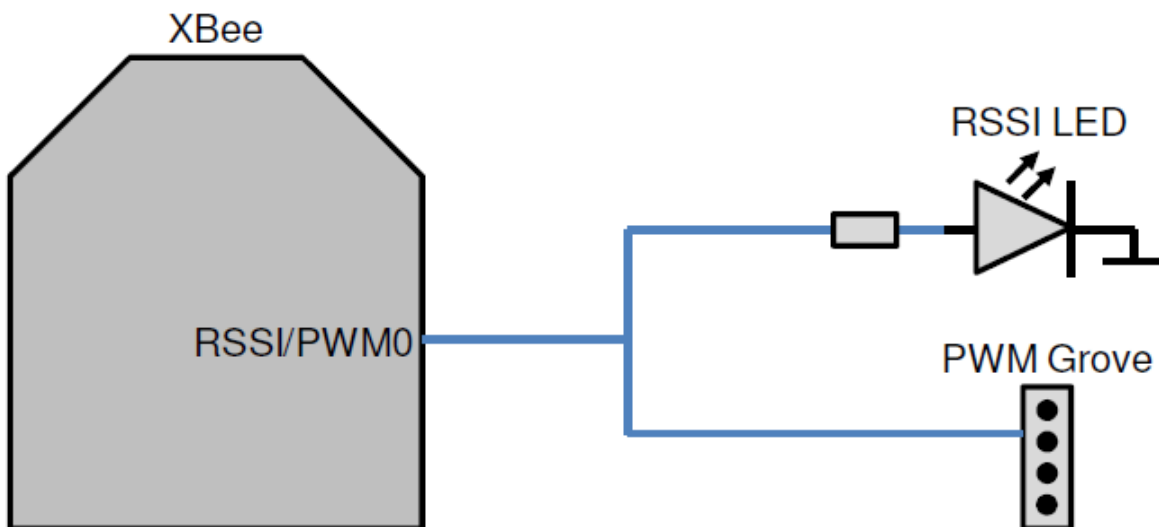
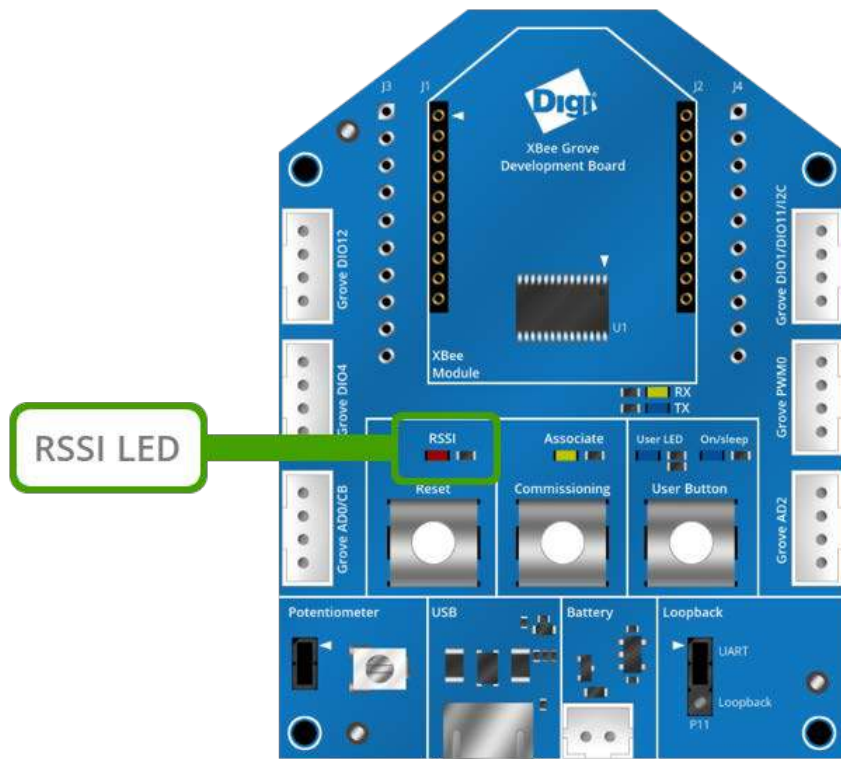

User LED and User button

The Xbee Grove Development Board provides a user LED and a user button. Both share the same Xbee I/O pin, DIO4.

Although the user LED and user button share the same pin, you can use only one at a time.

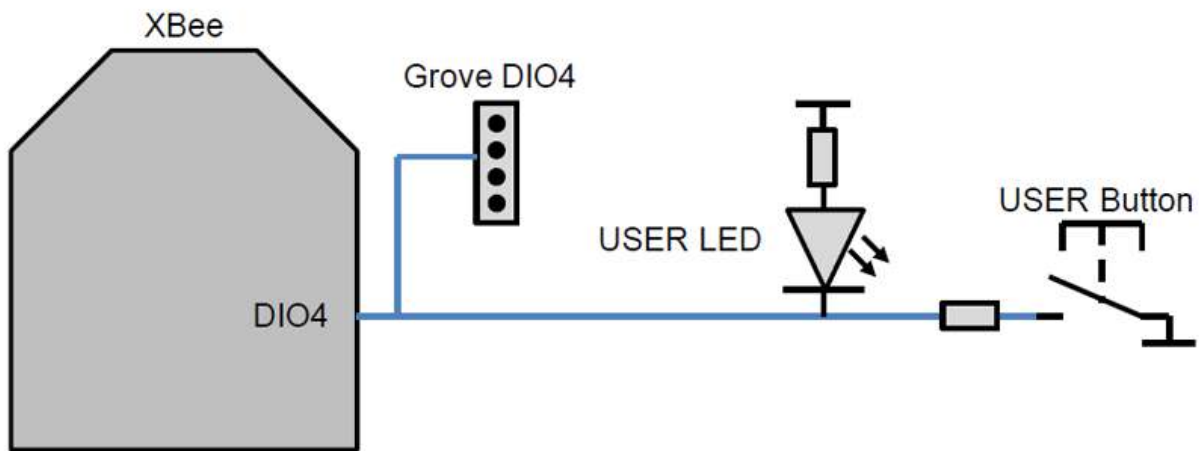
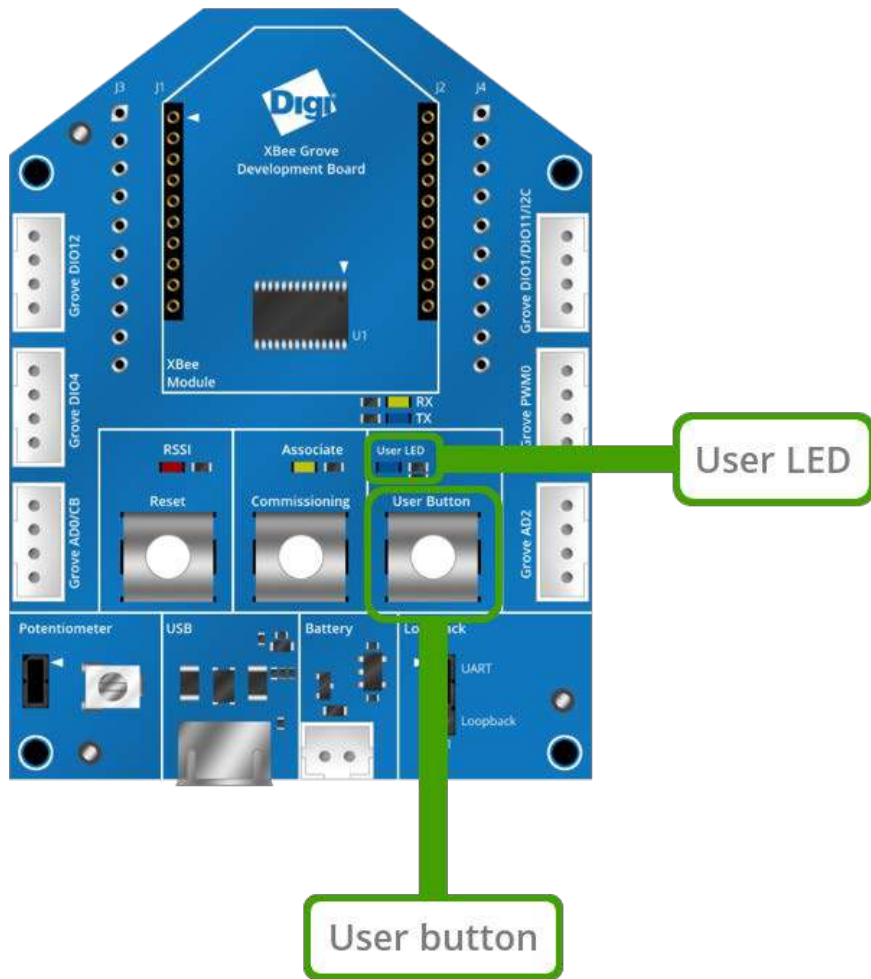

On/Sleep LED

The XBee Grove Development Board provides an LED connected to the On/Sleep pin (DIO9). This LED is on when the XBee module is awake, and off when it is asleep.

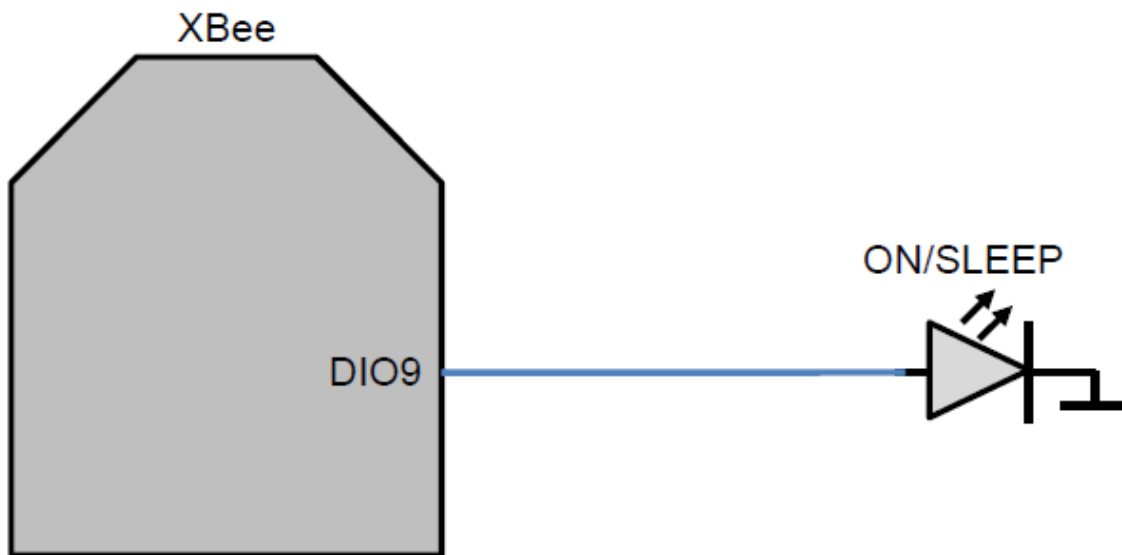
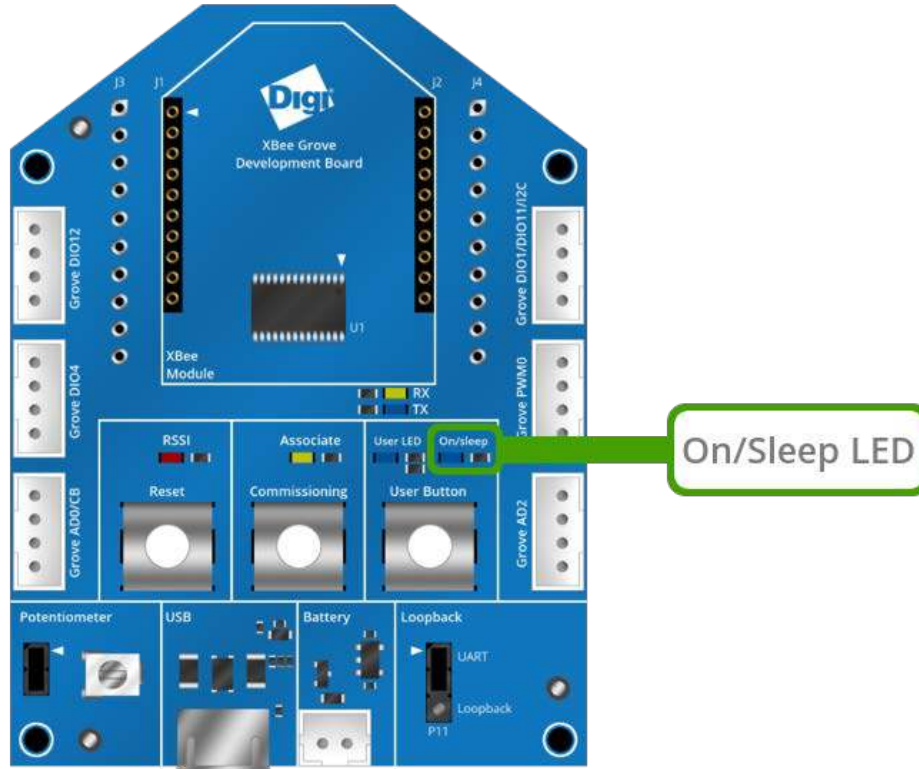

Potentiometer

The XBee Grove Development Board provides a 10K potentiometer to generate analog signal between 3.3V and 0V. The output of the potentiometer is connected to the AD3 pin (D3) of the XBee.

One jumper is used to disconnect the 3.3V supply from the potentiometer to save power when it's not used.

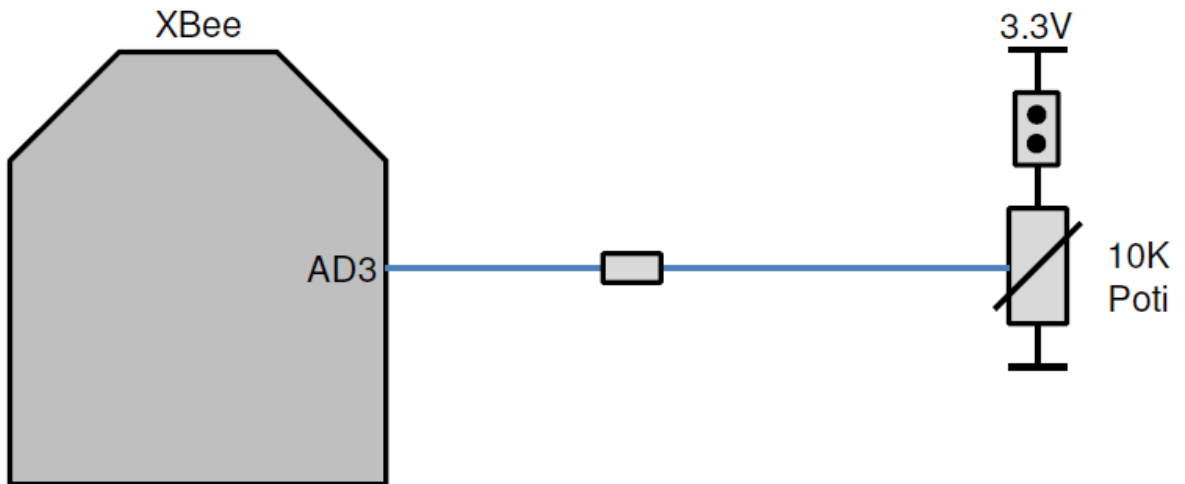
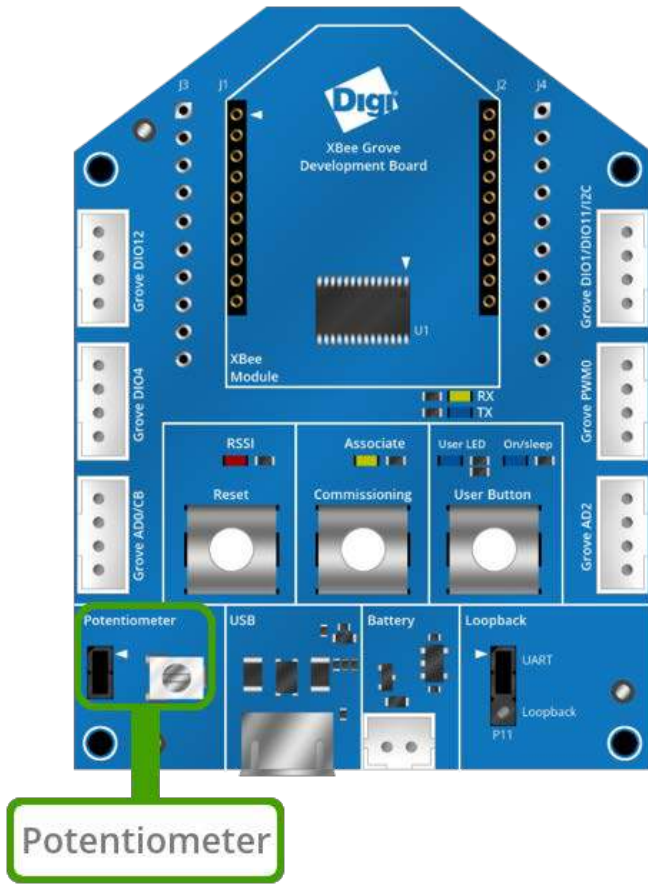

I2C

The XBee Grove Development Board provides an I2C bus. This I2C bus can be used with XBee programmable modules.

Regular XBee/XBee-PRO modules don't provide an I2C bus, but you can connect a digital Grove sensor.

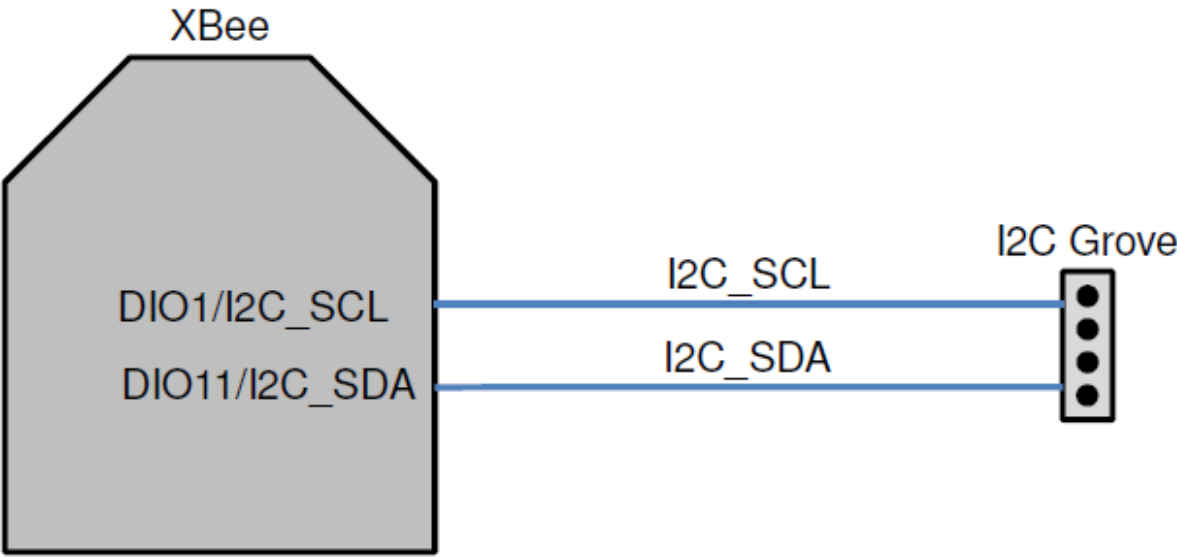
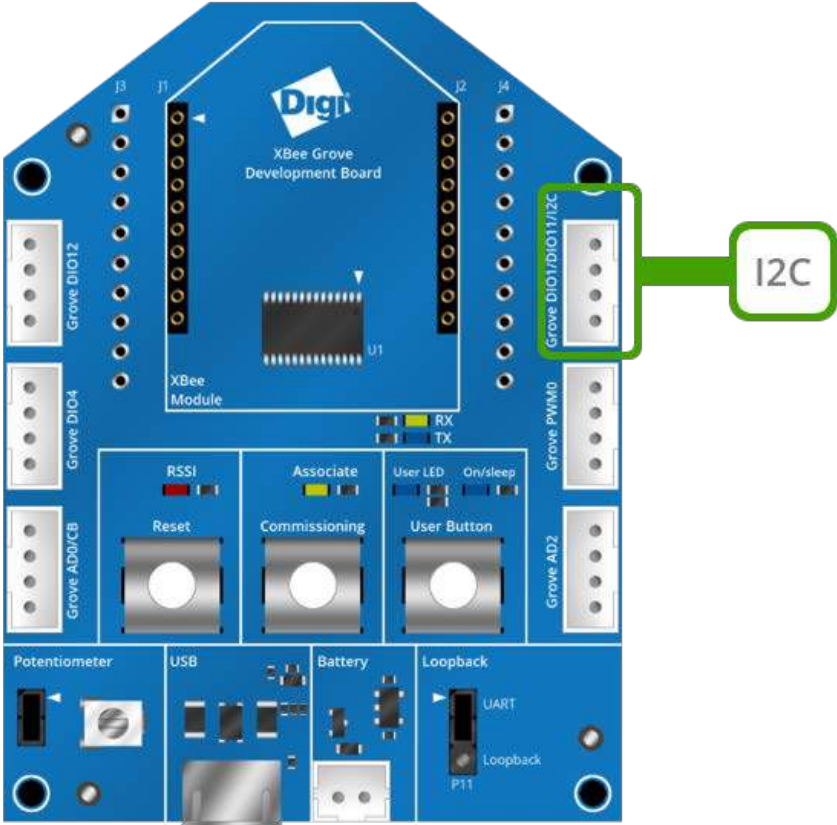

The following table shows the pinout of the Grove I2C connector:

Grove I2C	Signal	Comments
1	DIO1/I2C_SCL	
2	DIO11/I2C_SDA	
3	3.3V	
4	GND	

Grove connectors

The XBee Grove Development Board provides six Grove connectors connected to the XBee pins. Two connectors are connected to digital I/O pins, two connectors are connected to two digital/analog I/O pins, one connector is connected to the RSSI/PWM0 pin, and another is connected to the I2C bus of the microcontroller placed in the socket (programmable XBee.)

You can find a large list of Grove sensors and actuators that can be plugged in to these connectors [here](#).

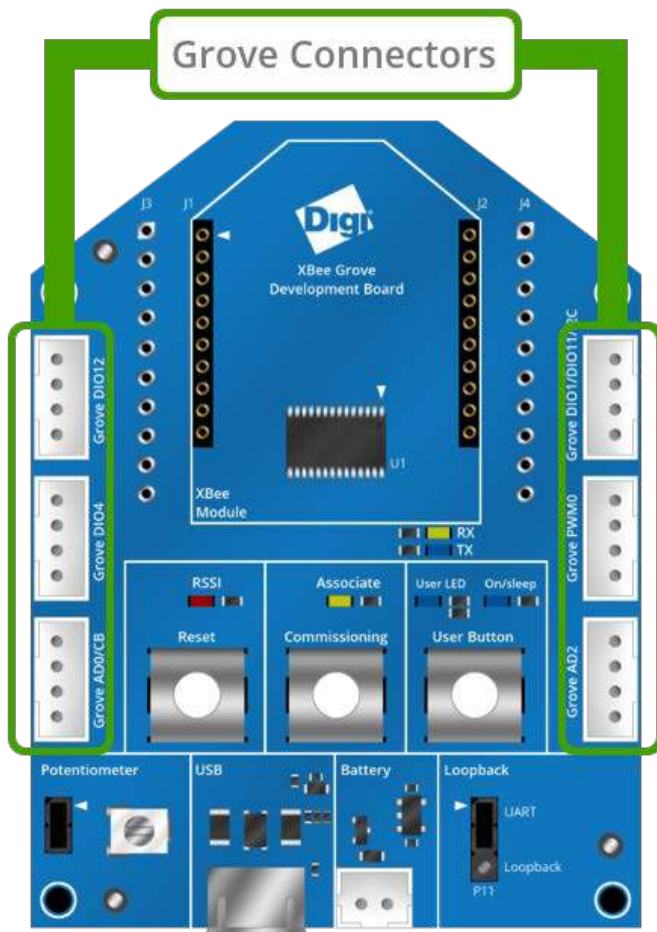

The following tables show the pinout of the Grove connectors:

Grove DIO12 Signal Comments

1	DIO12
2	-
3	3.3V
4	GND

Grove DIO4 Signal Comments

1	DIO4	Signal connected to user LED/button
2	-	
3	3.3V	
4	GND	

Grove AD0 Signal Comments

1	AD0/CB	Signal connected to commissioning button
2	-	
3	3.3V	
4	GND	

Grove I2C Signal Comments

1	DIO1/I2C_SCL	
2	DIO11/I2C_SDA	
3	3.3V	
4	GND	

Grove PWM0 Signal Comments

1	RSSI/PWM0	Signal connected to RSSI LED
2	-	
3	3.3V	
4	GND	

Grove AD2 Signal Comments

1	AD2
2	-
3	3.3V
4	GND

Loopback jumper

The XBee Grove Development Board provides a three-pin jumper to connect the UART to the USB (normal mode) or to make a loopback connection between the RX and TX signals of the UART.

In loopback mode, the RX line is connected to the TX line, which causes any received data to be transmitted back. This is used in transparent mode to check the signal strength and perform a range test.

