

| REVISIONS | | | | |
|-----------|-----|-------------|--------|----------|
| P/F | LTR | DESCRIPTION | DATE | APPROVED |
| ✓ | ✓ | REV-REDWJ | 5-2-83 | MS/2H |

THIS DRAWING IS UNPUBLISHED. RELEASED FOR PUBLICATION MAY 3, 1983. BY AMP INCORPORATED, HARRISBURG, PA. ALL INTERNATIONAL RIGHTS RESERVED. AMP PRODUCTS MAY BE COVERED BY U.S. AND FOREIGN PATENTS AND/OR PATENTS PENDING.

1. FOR USE WITH: RG-16/U, 179/U, 187/U CABLE.
2. CRIMPING TOOL: 69245-1.
3. SEE I.S. 1799-3.

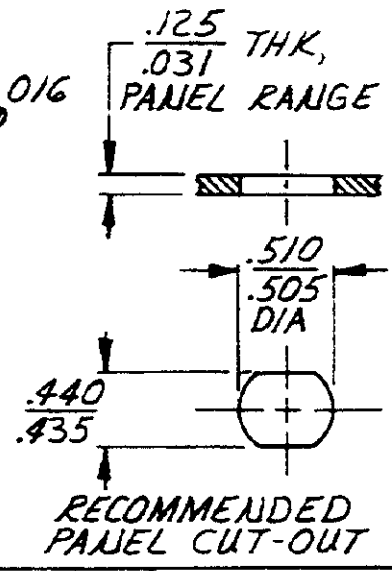
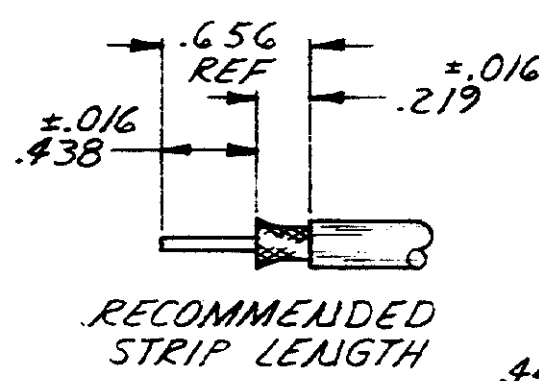
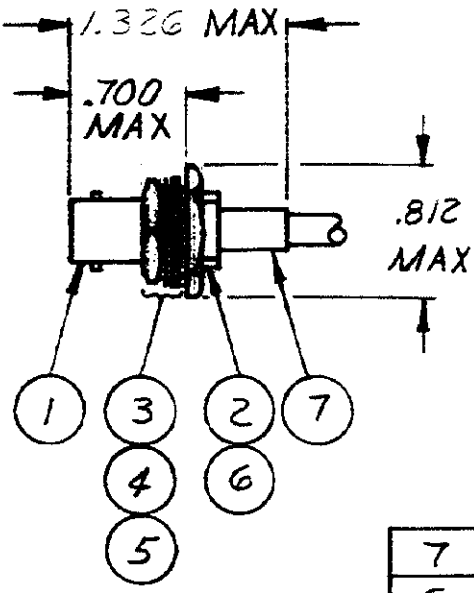

| ITEM | QTY | DESCRIPTION | PART NO |
|------|-----|----------------|------------|
| 7 | 1 | FERRULE | 328666 |
| 6 | 1 | GASKET | 2-329106-1 |
| 5 | 1 | LOCK WASHER | 329632 |
| 4 | 1 | JAM NUT | 329631 |
| 3 | 1 | GASKET | 329633 |
| 2 | 1 | CRIMP END ASSY | 50793-5 |
| 1 | 1 | JACK ASSY, BHD | 329800 |

UNLESS OTHERWISE SPECIFIED DIMENSIONS ARE IN INCHES. TOLERANCES ON: DECIMALS ± .005 ANGLES ± .005

CONTRACT NO _____

DR *M. E. ...* 5-3-83

CHK *S. S. Heide* 9/8/83

APPD *M. ...* 12/1/83

APPD *M. ...* 12/1/83

DSGN APPD _____

OTHER APPD _____

AMP | AMP INCORPORATED
Harrisburg, Pa. 17105

NAME **CONNECTOR, COAXIAL, RF, JACK, BHD, SERIES BNC**

SIZE **A** FSCM NO **00779** DRAWING NO **2-329458-1**

SCALE **NTS** SHEET _____