

SMA 2.9 MALE - SMP FEMALE STR.ADAPTER

R191.967.002

COND. 100

Série : ADAPT

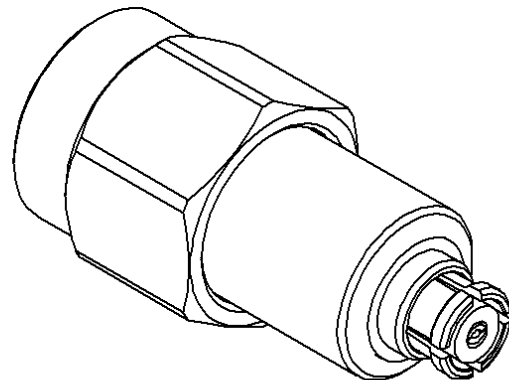
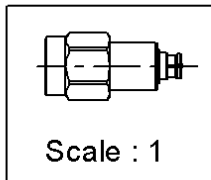
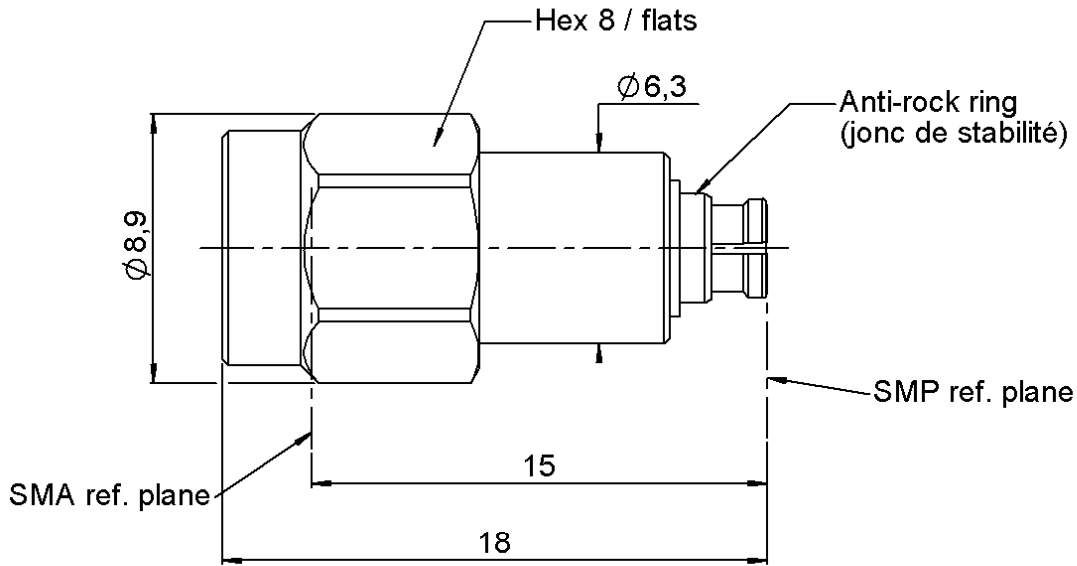

All dimensions are in mm.

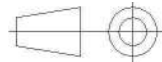

COMPONENTS	MATERIALS	PLATING (µm)
BODY	STAINLESS STEEL	PASSIVATED
CENTER CONTACT	BERYLLIUM COPPER	GOLD 1.27 OVER NICKEL 1.27
OUTER CONTACT	BERYLLIUM COPPER, BRASS	GOLD 0.2 OVER NICKEL 2
INSULATOR	PTFE+KAPTON	
GASKET	SILICONE RUBBER	
OTHERS PARTS	STAINLESS STEEL	PASSIVATED
-	-	-
-	-	-

Issue : 0823 B

In the effort to improve our products, we reserve the rights to make changes judged to be necessary.



SMA 2.9 MALE - SMP FEMALE STR.ADAPTER

R191.967.002

COND. 100

Série : ADAPT

PACKAGING

SPECIFICATION

Standard	Unit	Other
100	'W' option	Contact us

ELECTRICAL CHARACTERISTICS

ENVIRONMENTAL

Impedance	50	Ω
Frequency	0-40	GHz
VSWR	1.5 + 0,0000	x F(GHz) Maxi
Insertion loss	0.1	\sqrt{F} (GHz) dB Maxi
RF leakage	- (NA)	- F(GHz)) dB Maxi
Voltage rating	335	Veff Maxi
Dielectric withstanding voltage	500	Veff mini
Insulation resistance	5000	M Ω mini

Operating	-65/+165	$^{\circ}$ C
Hermetic seal	NA	Atm.cm3/s
Panel leakage	NA	

MECHANICAL CHARACTERISTICS

OTHER CHARACTERISTICS

Center contact retention		
Axial force – Mating end	27	N mini
Axial force – Opposite end	27	N mini
Torque	NA	N.cm mini
Recommended torque		
Mating	SMA2.	110 N.cm
	SMP	0 N.cm
	-	0 N.cm
Panel nut	NA	N.cm
Mating life	100	Cycles mini
Weight	3,5800	g

Issue : 0823 B

In the effort to improve our products, we reserve the rights to make changes judged to be necessary.

RADIAL 