



STEVAL-IHM011V1

IGBT power module kit - SEMITOP2[®] power board

Data Brief

Features

- 34-pin dedicated motor control connector
- 5-pins hall sensor/encoder input
- Tachometer sensor input
- Support for 5 V or 3.3 V microcontroller
- Three configurations for current detection:
 - 1 shunt resistor
 - 3 shunt resistors or
 - 3 external ICS (insulated current sensor)
- Current amplification network
- BEMF detecting network
- Hardware current protection
- Hardware thermal protection (using on-board temperature sensor)
- Resistive brake network



Description

The STEVAL-IHM011V1 evaluation board is a complete platform for evaluating the STMicroelectronics power module SEMITOP2[®] devices. Based on a cost-effective, flexible and open design, it is an evaluation platform which is compatible with the latest STMicroelectronics microcontroller-based solutions. It includes the 10A, 600 V STG3P2[™]111NSUB IGBT power module (see note 1). This evaluation board has a motor control connector (mc-connector) and hardware features for developing motor control applications. It also includes hardware protection features such as current and thermal protection.

Note: 1 *The kit has been designed and tested to work with European mains (maximum 380 V_{bc})*

March 2008

Rev 1

1/5

For further information contact your local STMicroelectronics sales office.

www.st.com

1 Board schematic

Figure 1. Schematic 1/2

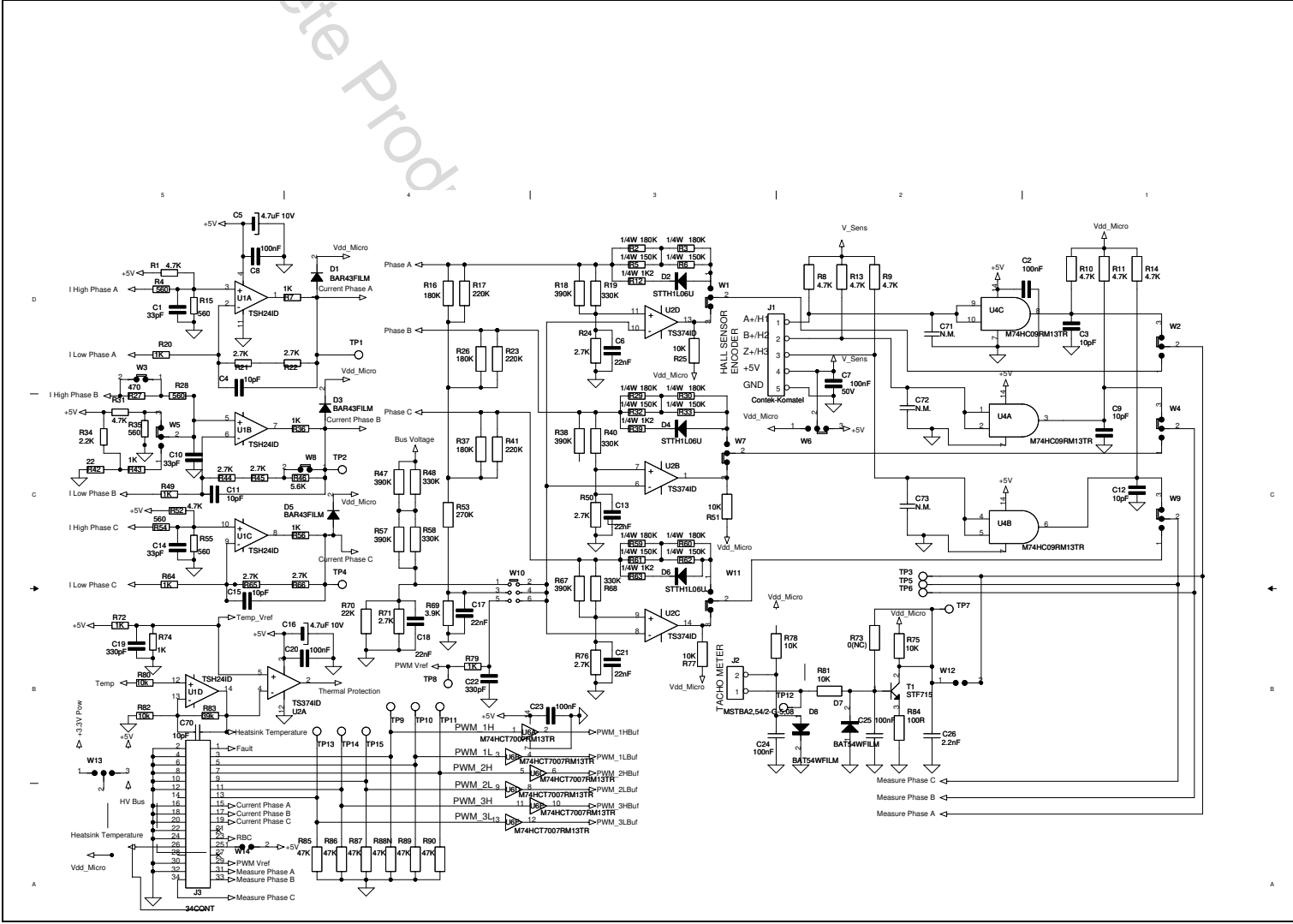
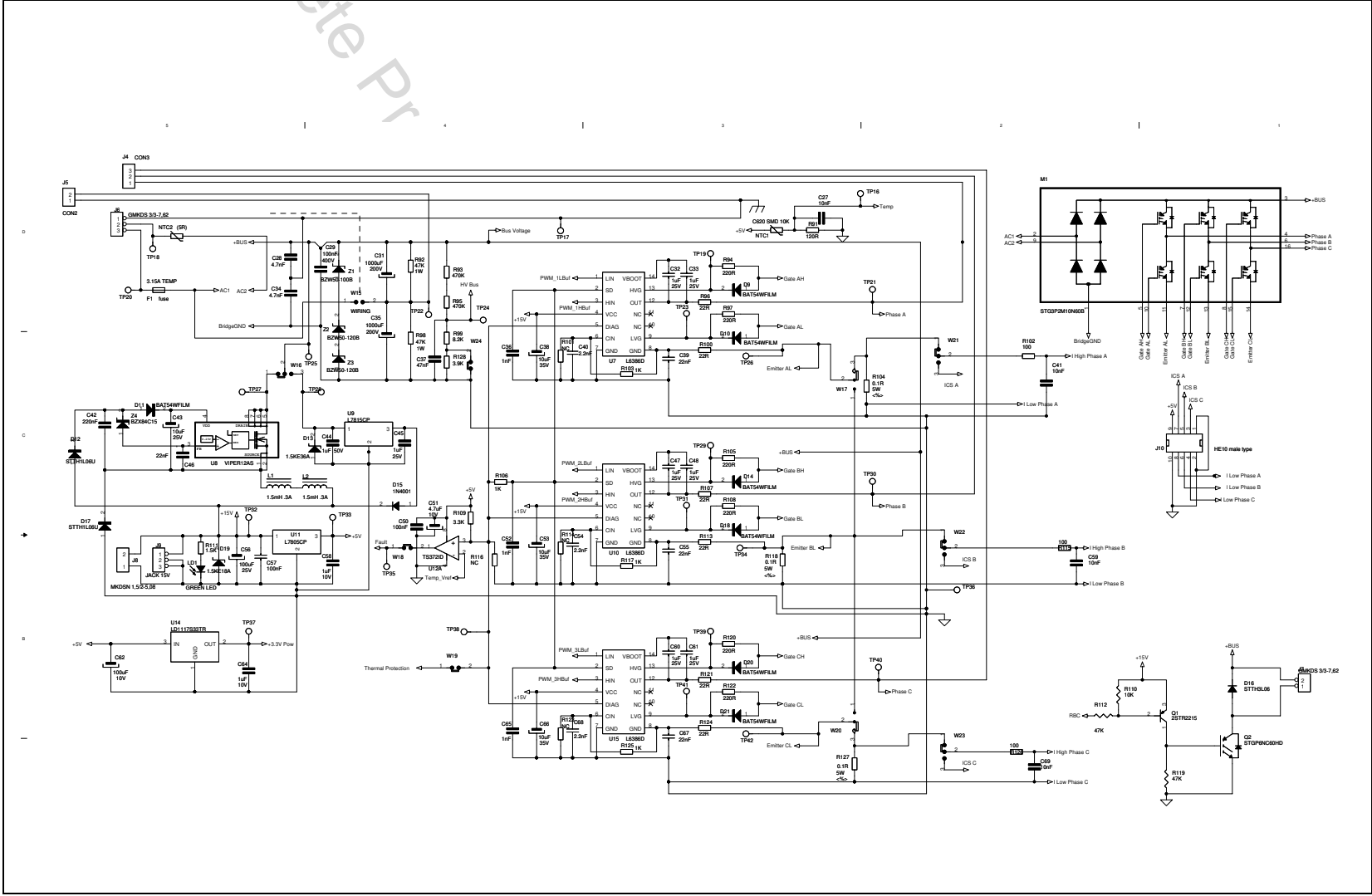

Figure 2. Schematic 1/2



2 Revision history

Table 1. Document revision history

Date	Revision	Changes
03-Mar-2008	1	Initial release.

Obsolete Product(s) - Obsolete Product(s)

Please Read Carefully:

Information in this document is provided solely in connection with ST products. STMicroelectronics NV and its subsidiaries ("ST") reserve the right to make changes, corrections, modifications or improvements, to this document, and the products and services described herein at any time, without notice.

All ST products are sold pursuant to ST's terms and conditions of sale.

Purchasers are solely responsible for the choice, selection and use of the ST products and services described herein, and ST assumes no liability whatsoever relating to the choice, selection or use of the ST products and services described herein.

No license, express or implied, by estoppel or otherwise, to any intellectual property rights is granted under this document. If any part of this document refers to any third party products or services it shall not be deemed a license grant by ST for the use of such third party products or services, or any intellectual property contained therein or considered as a warranty covering the use in any manner whatsoever of such third party products or services or any intellectual property contained therein.

UNLESS OTHERWISE SET FORTH IN ST'S TERMS AND CONDITIONS OF SALE ST DISCLAIMS ANY EXPRESS OR IMPLIED WARRANTY WITH RESPECT TO THE USE AND/OR SALE OF ST PRODUCTS INCLUDING WITHOUT LIMITATION IMPLIED WARRANTIES OF MERCHANTABILITY, FITNESS FOR A PARTICULAR PURPOSE (AND THEIR EQUIVALENTS UNDER THE LAWS OF ANY JURISDICTION), OR INFRINGEMENT OF ANY PATENT, COPYRIGHT OR OTHER INTELLECTUAL PROPERTY RIGHT. UNLESS EXPRESSLY APPROVED IN WRITING BY AN AUTHORIZED ST REPRESENTATIVE, ST PRODUCTS ARE NOT RECOMMENDED, AUTHORIZED OR WARRANTED FOR USE IN MILITARY, AIR CRAFT, SPACE, LIFE SAVING, OR LIFE SUSTAINING APPLICATIONS, NOR IN PRODUCTS OR SYSTEMS WHERE FAILURE OR MALFUNCTION MAY RESULT IN PERSONAL INJURY, DEATH, OR SEVERE PROPERTY OR ENVIRONMENTAL DAMAGE. ST PRODUCTS WHICH ARE NOT SPECIFIED AS "AUTOMOTIVE GRADE" MAY ONLY BE USED IN AUTOMOTIVE APPLICATIONS AT USER'S OWN RISK.

Resale of ST products with provisions different from the statements and/or technical features set forth in this document shall immediately void any warranty granted by ST for the ST product or service described herein and shall not create or extend in any manner whatsoever, any liability of ST.

ST and the ST logo are trademarks or registered trademarks of ST in various countries.

Information in this document supersedes and replaces all information previously supplied.

The ST logo is a registered trademark of STMicroelectronics. All other names are the property of their respective owners.



© 2008 STMicroelectronics - All rights reserved

STMicroelectronics group of companies

Australia - Belgium - Brazil - Canada - China - Czech Republic - Finland - France - Germany - Hong Kong - India - Israel - Italy - Japan - Malaysia - Malta - Morocco - Singapore - Spain - Sweden - Switzerland - United Kingdom - United States of America

www.st.com

