

AFE74xxEVM User's Guide

This user guide demonstrates how to program an AFE7422EVM or AFE7444EVM (AFE74xxEVM). Details on configurable modes are included in Table 1. Throughout this document, the terms evaluation board, evaluation module, and EVM are synonymous with the AFE74xxEVM.

Table 1. RF DAC and ADC Operating Mode Configurations for the AFE7422

Mode #	Single/ Dual Band	Max Signal BW (TX/RX) (MHz)	Serdes Rate (Gbps)	FS _{DAC} (Gsp/s)	TX Resolution (bit)	Inter- polation	TX LMFS	FS _{ADC} (Gsp/s)	RX Resolution (bit)	Deci- mation	RX LMFS
1	1	1200/1500	15	9	16	6x	84111	3	16	-	82240
2		800	10	9	16	9x	84111	3	16	3x	84220
3			15	9	12	9x	44320	3	12	3x	44320
4		600	15	9	16	12x	44210	3	16	4x	44210
5			15	6	16	8x	44210	3	16	4x	44210
6		300	7.5	9	16	24x	44210	3	16	8x	44210
7		200	10	9	16	36x	24410	3	16	12x	24410
8			10	9	16	36x	24410	2.25	16	9x	24410
9			10	6	16	24x	24410	3	16	12x	24410
10			10	9	16	36x	48410	3	16	12x	48410
11	2	200	10	9	16	36x	48410	2.25	16	9	48410

Contents

1	Introduction	3
2	Hardware.....	3
	2.1 AFE74xxEVM Orientation	3
	2.2 Equipment	4
	2.3 Test Setup	5
3	Software.....	6
	3.1 Install the High Speed Data Converter (HSDC) Pro Software	6
	3.2 Install HSDC Pro Patch Files	6
	3.3 Install the Configuration GUI Software	6
4	Setup	7
	4.1 Connect the EVM and TSW14J57EVM.....	7
	4.2 Connect the Power Supplies	7
	4.3 Connect the Signal Generators	7
	4.4 Connect the Spectrum Analyzer	7
	4.5 Turn On the TSW14J57EVM Power Supply and Connect to the PC	7
	4.6 Turn On the AFE74xxEVM Power Supply and Connect to the PC	7
5	Programming	8
	5.1 Program the TSW14J57EVM	8
	5.2 Send Tone	9
	5.3 Clock Modes	10
	5.4 Verify DAC Output on Spectrum Analyzer	19
	5.5 Capture Tone	20
	5.6 AFE74xx NCO and DSA Settings	21

List of Figures

1	AFE74xxEVM Top View	3
2	Test Setup	5
3	HSDCPro Patch v4.90.01	6
4	HSDC Pro GUI Connecting to the TSW14J57EVM	8
5	HSDC Pro DAC Tone Setup	9
6	Location of Jumper J9 Circled in Yellow	10
7	AFE External Clock-In (AFECLK) Location	10
8	Optional Reference Clock Source Input Location	11
9	EVM Selection Page	12
10	External Clock Selection Page	12
11	External DAC Clock Selection	13
12	External Clock: ADC Clock Selection	13
13	AFE Mode Selection Page	14
14	Set Mode and Run Complete Startup Sequence	14
15	Quick-Start Page	15
16	Clock Selection Page	16
17	AFE Mode Selection Page Displaying Mode 4.....	17
18	Set Mode and Run Complete Startup Sequence	18
19	Two-Tone DAC Output Centered at 1710 MHz and Spaced 5 MHz Apart.....	19
20	Troubleshooting the AFE74xxEVM DAC	19
21	HSDC Pro ADC Settings	20
22	Tone Capture Centered at 30 MHz	20
23	NCO and DSA Settings Location	21
24	NCO Adjustment Settings	21
25	DSA Adjustment Settings	22

Trademarks

Windows is a trademark of Microsoft Corporation.
All other trademarks are the property of their respective owners.

1 Introduction

The AFE74xxEVM is an evaluation board used to evaluate the AFE74xxEVM family (AFE7422 and AFE7444) of analog-to-digital converters (ADC) from Texas Instruments.

The AFE74xxEVM is a dual- or quad-channel, wideband, RF sampling transceiver based on 14-bit, 9-GSPS DACs and 14-bit, 3-GSPS ADCs. Operating at RF frequencies up to 5.2 GHz, these devices enable direct RF sampling through the C-band without the need for additional frequency-conversion stages. The AFE74xxEVM contains an 8-lane (8 TX + 8 RX), subclass 1 compliant JESD204B204B interface capable of operating as high as 15 Gbps. A bypassable on-chip PLL simplifies clocking with optional clock output.

The digital data from the AFE74xxEVM board is quickly and easily captured with the [TSW14J57EVM](#) or [TSW14J56EVM](#) data capture boards. The TSW14J57EVM captures the high-speed serial data, decodes the data, stores the data in memory, and then uploads the data to a connected PC through a USB interface for analysis. The *High-Speed Data Converter Pro* (HSDC Pro) software on the PC communicates with the hardware and processes the data. With proper hardware selection in the HSDC Pro software, the TSW14J57 device is automatically configured to support the wide range of operating speeds of the AFE74xxEVM. In the following sections of this document, the AFE74xxEVM is referred to as the EVM and the AFE74xx device is referred to as the AFE. The TSW14J57EVM is referred to as the TSW14J57EVM. This document describes how to setup the EVM on the bench with the proper equipment to evaluate the full performance of the ADC device.

2 Hardware

2.1 AFE74xxEVM Orientation

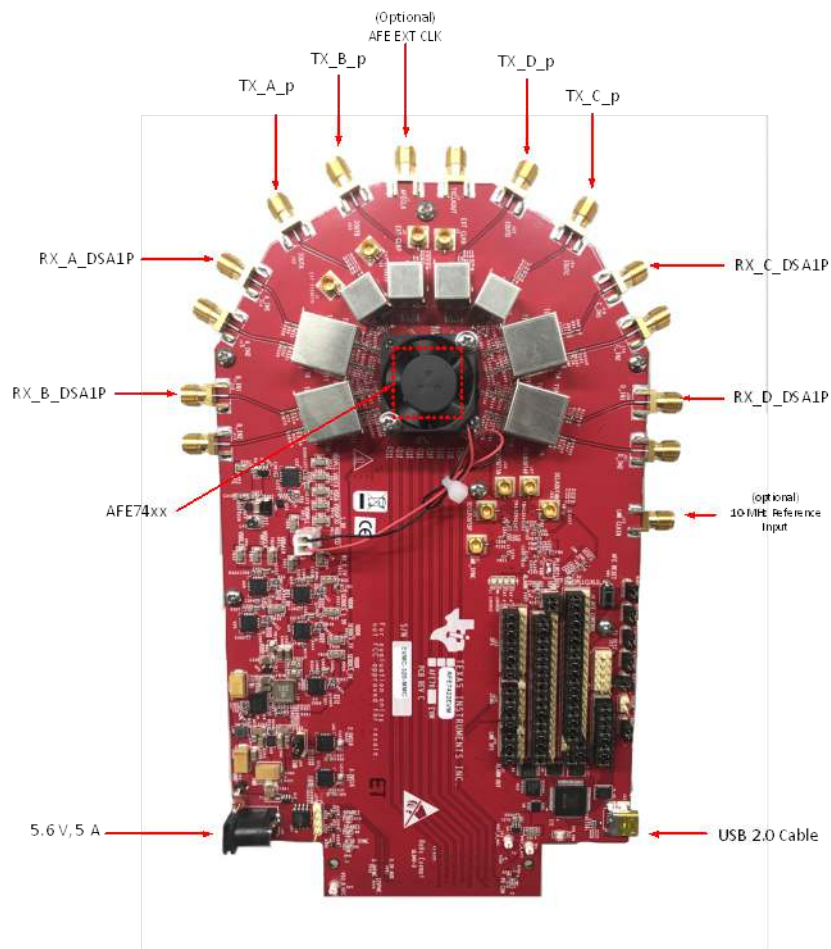

Figure 1. AFE74xxEVM Top View

2.2 Equipment

The following equipment and documents are included in the EVM evaluation kit:

- Evaluation board (EVM)
- Mini-USB cable
- Power cable

The following equipment is not included in the EVM evaluation kit, but is required for evaluation of this product:

- TSW14J57EVM or TSW14J56EVM data capture board and related items
- HSDC Pro software
- PC computer running Windows™ XP, 7, or 8 operating systems
- One low-noise signal generator for analog input. TI recommends the following generators:
 - Keysight E8663D
 - Rohde and Schwarz SMA100A
- One spectrum analyzer
- Bandpass filter for analog input signal (1730 MHz or desired frequency). The following filters are recommended:
 - Bandpass filter, greater than or equal to 60-dB harmonic attenuation, less than or equal to 5% bandwidth, greater than 18-dBm power, less than 5-dB insertion loss
 - Trilithic™ 5VH-series tunable BPF
 - K&L Microwave™ BT-series tunable BPF
 - TTE KC6 or KC7-series fixed BPF
- Signal-path cables, SMA or BNC (or both SMA and BNC)

By default, the AFE74xxEVM has an onboard clocking solution. A single onboard jumper modification is required to enable external clocking. Make sure Jumper JP9 on the AFE74xxEVM is set (2.5 VCLK_ENB) to position 1-2. If external clocking is used, the following equipment is recommended:

- Two low-noise signal generators. TI recommends models similar to the analog input source.
- A bandpass filter for the DEVCLK input. TI recommends a filter similar to the analog-input path filter.

2.3 Test Setup

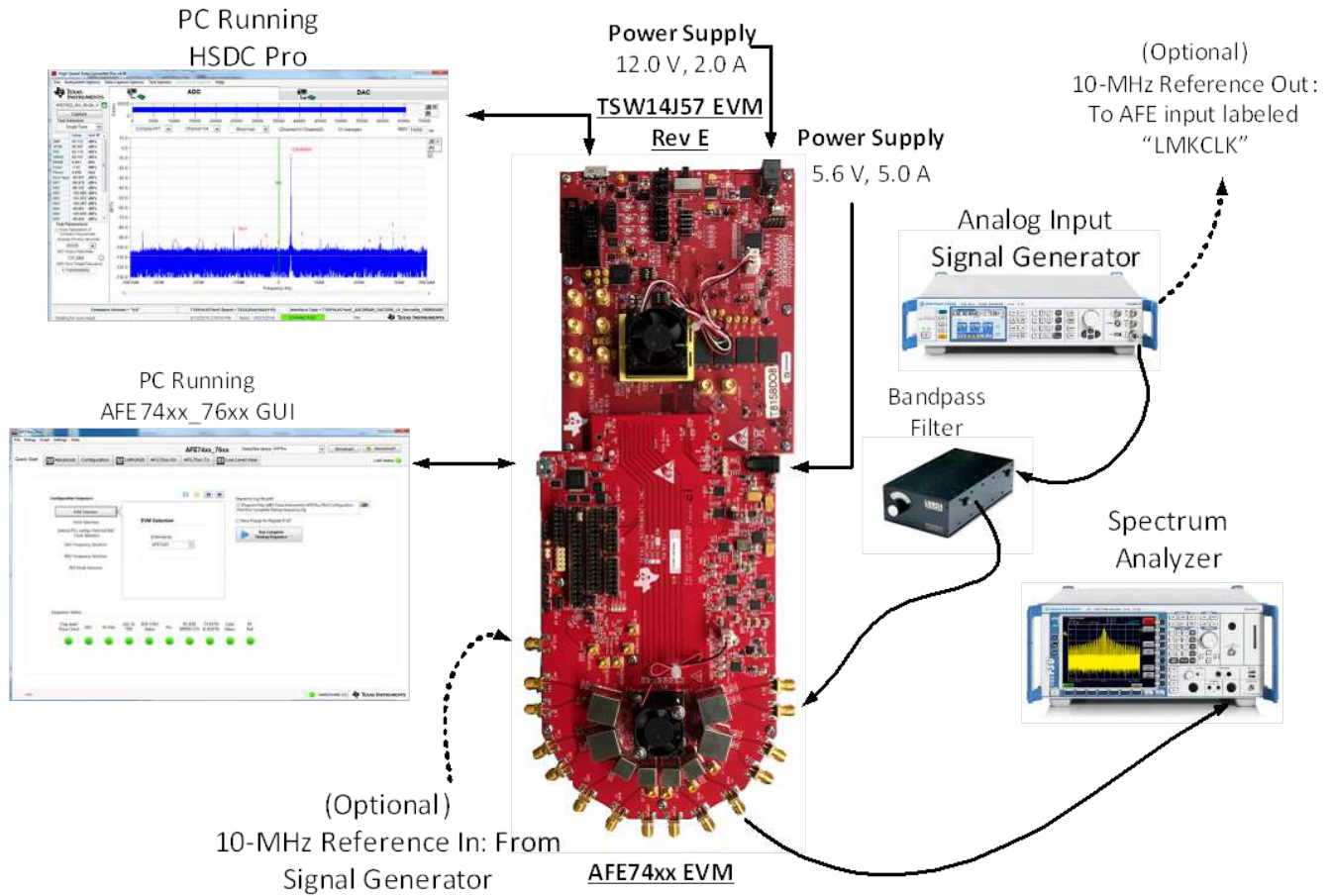

Figure 2. Test Setup

3 Software

All required software are available for download at the following link:
www.ti.com/licreg/docs/swlicexportcontrol.tsp?form_id=288371&prod_no=AFE7422-DESIGN&ref_url=asc_dc_hsc

After completing the export control form, the link takes you to a list of additional application links. Click each link and follow the instructions to install the associated software. The following subsections provide additional installation instructions.

3.1 Install the High Speed Data Converter (HSDC) Pro Software

Click the link labeled *High Speed Data Converter Pro - Installer vx.x.exe* to download the latest version of the HSDC Pro software, where *vx.x* is the latest version number.

3.2 Install HSDC Pro Patch Files

1. Launch *HSDCPro Patch vx.x.exe*
2. As shown in [Figure 3](#), copy and paste the following path into the program:
C:\Program Files (x86)\Texas Instruments\High Speed Data Converter Pro
3. Press *Next*

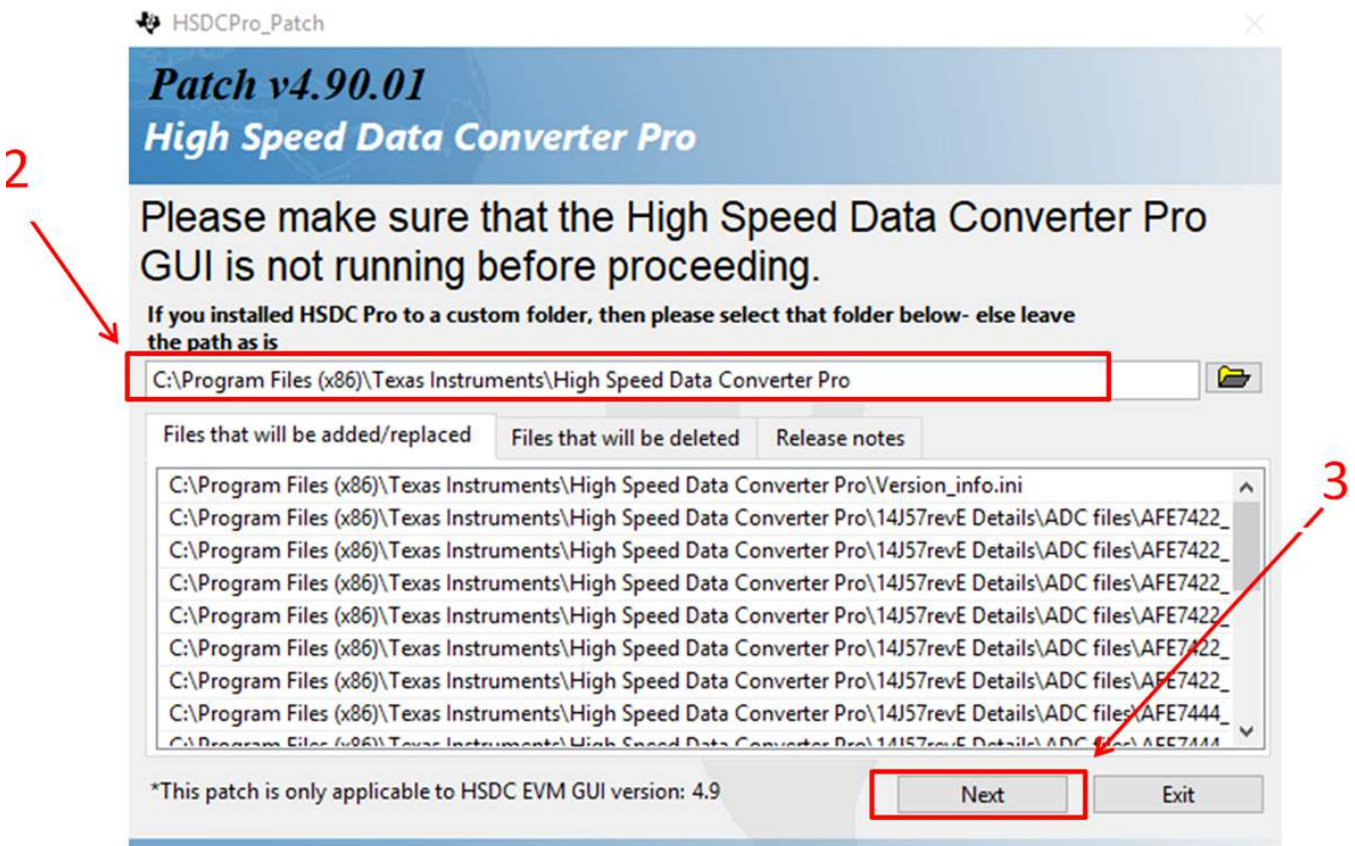

Figure 3. HSDCPro Patch v4.90.01

3.3 Install the Configuration GUI Software

Launch *Setup_AFE74xx_76xx_EVM.exe* to download the AFE74xxEVM GUI software, and follow the instructions.

4 Setup

4.1 Connect the EVM and TSW14J57EVM

1. Confirm that the power switch on the TSW14J57EVM is in the off position. Connect the power cable to a 12-V DC (minimum 3 A) power supply. Make sure the proper supply polarity by confirming that the outer surface of the barrel connector is GND and the inner portion of the connector is 12 V. Connect the power cable to the EVM power connector.
2. Confirm that the power supply on the AFE74xxEVM is off. Connect the power cable to a 5.6-V DC (minimum 5 A) power supply.

4.2 Connect the Power Supplies

With the power off, connect the AFE74xxEVM to the TSW14J57EVM through the FMC connector, as shown in the test setup display of [Figure 2](#). Make sure that the standoffs provide the proper height for robust connector connections.

4.3 Connect the Signal Generators

With the RF output signal generator disabled, connect a signal generator to the I_IN_A input of the AFE74xxEVM through a bandpass filter and attenuator at the SMA connector. This signal generator must be low noise. TI recommends a Trilithic-tunable bandpass filter to filter the signal from the generator. Configure the signal generator for 1730 MHz, -11 dBm.

4.3.1 Connect an External Clock (Optional)

1. Connect a signal generator to the AFECLK input of the EVM through a bandpass filter. *Do not power on until instructed.* This signal generator must be a low-noise signal generator. TI recommends a Trilithic-tunable bandpass filter to filter the signal coming from the generator. Configure the signal generator for the desired clock frequency in the range of 0.8 GHz to 9 GHz. For best performance when using an RF signal generator, the power input to the CLK SMA connector must be 18 dBm. The signal generator must increase above 18 dB by an amount equal to any additional attenuation in the clock signal path, such as the insertion loss of the bandpass filter. For example, if the filter insertion loss is 2 dB, the signal generator must be set to $18 \text{ dBm} + 2 \text{ dB} = 20 \text{ dBm}$.
2. Connect the 10-MHz reference out signal from the signal generator used to clock the AFE74xxEVM to the LMKCLK input of the EVM.

4.4 Connect the Spectrum Analyzer

1. Connect a spectrum analyzer to the I_OUTA output of the EVM with an SMA cable.
2. Set the center frequency of the spectrum analyzer to 1710 MHz with a span of 50 MHz to 100 MHz.

4.5 Turn On the TSW14J57EVM Power Supply and Connect to the PC

1. Turn on the power switch of the TSW14J57EVM.
2. Connect a mini-USB cable from the PC to the TSW14J57EVM
3. If this is the first time connecting the TSW14J57EVM to the PC, follow the onscreen instructions to automatically install the device drivers. See the [TSW14J57EVM user's guide](#) for specific instructions.

4.6 Turn On the AFE74xxEVM Power Supply and Connect to the PC

1. Turn on the 5-V power supply to power up the EVM.
2. Connect the EVM to the PC with the mini-USB cable.

5 Programming

For the cases in this section, mode 4 is used. Other modes can be used following the same steps. See [Table 1](#) for a list of modes.

5.1 Program the TSW14J57EVM

1. Open the HSDC Pro software. Your screen should look like [Figure 4](#).
2. Click *OK* to confirm the serial number of the TSW14J57EVM device. If multiple TSWxxxx boards are connected, select the model and serial number of the board connected to the AFE74xxEVM 3.
3. When prompted, click *Yes* to update the firmware.

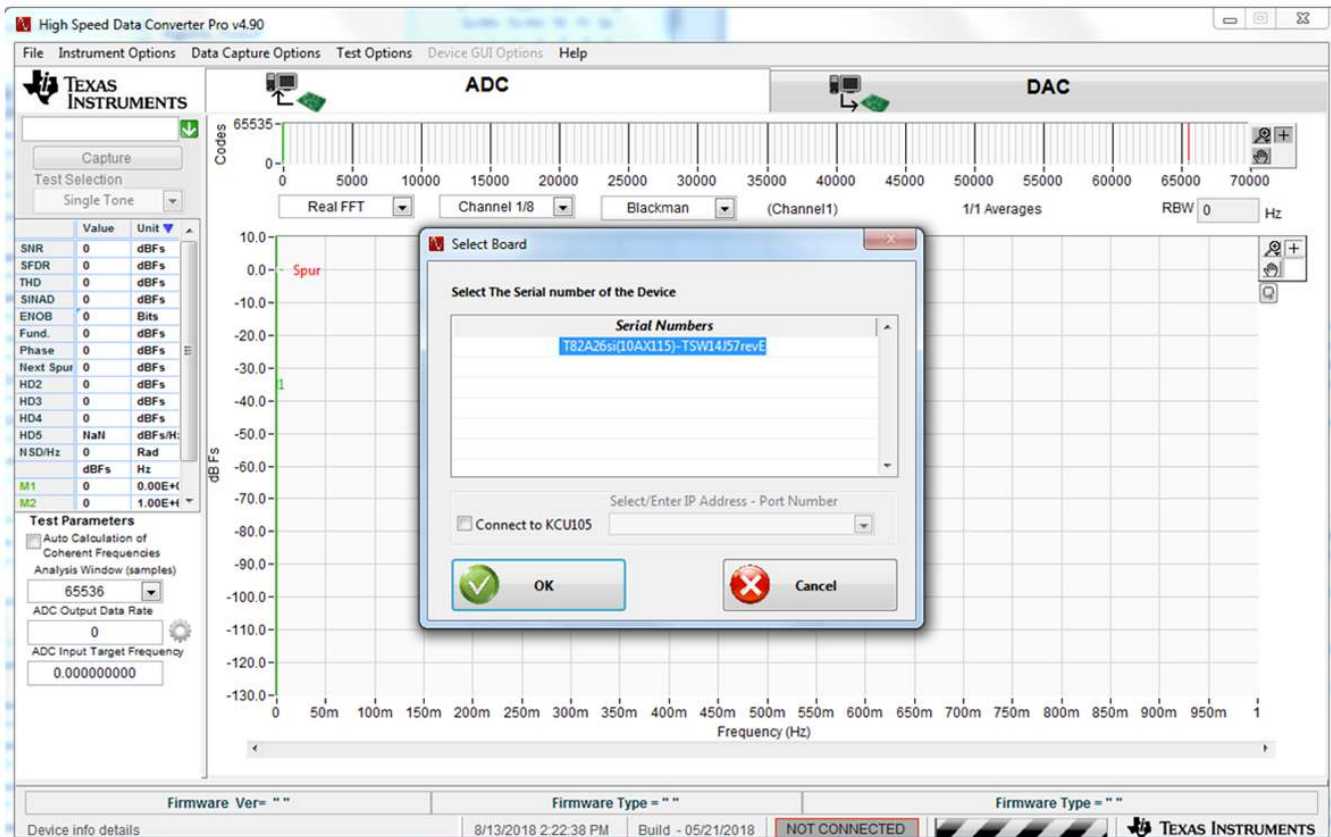

Figure 4. HSDC Pro GUI Connecting to the TSW14J57EVM

5.2 Send Tone

1. Navigate to the *DAC* tab.
2. Select the ini file from the drop-down menu, and then select the *AFE74xx_TX_Mode_4* file, as shown in [Figure 5](#)).
3. Enter the DAC output data rate, which is 737.28M for mode 4. This number must be equal to sample rate of the DAC divided by the interpolation factor.
4. Enter the following parameters to generate two tones, as shown in [Figure 5](#).
 - Tone BW = 5 M
 - # = 2
 - Tone Center = 10 M
 - Tone Selection = complex
5. Press *Create Tones*
6. Press *Send* after the LMK is programmed through the AFE74xx GUI

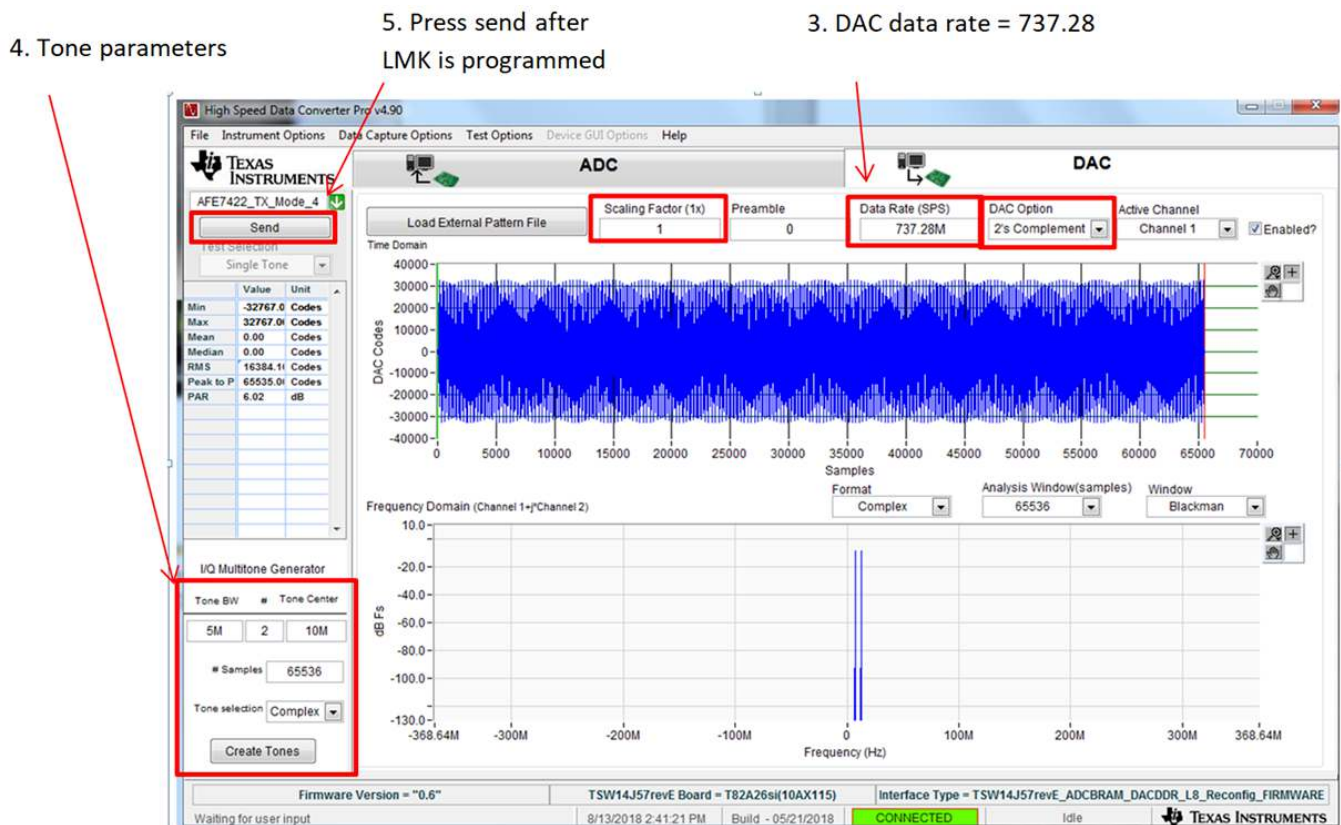

Figure 5. HSDC Pro DAC Tone Setup

5.3 Clock Modes

5.3.1 External Clock Mode

5.3.1.1 Hardware Adjustments for External Clock Mode

NOTE: To use the external clock, move jumper JP9 to position 1-2. Jumper JP9 is located near the AFE74xxEVM power supply, and is circled in yellow in [Figure 6](#).

Jumper JP9



Figure 6. Location of Jumper J9 Circled in Yellow

1. Place the external clock signal at the AFE EXT CLK SMA input, as shown in [Figure 7](#). Make sure the frequency of this signal matches the desired DAC clock frequency. Set the signal power to 20 dBm.

NOTE: Do not power on the external clock signal generator until after the LMK is programmed.

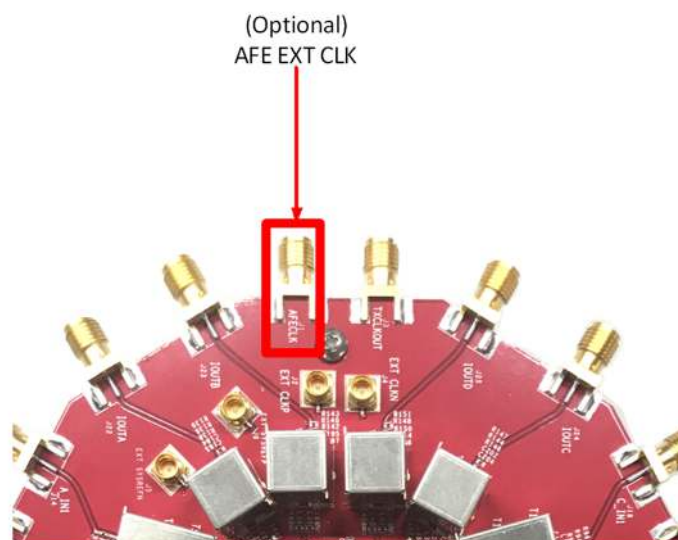

Figure 7. AFE External Clock-In (AFECLK) Location

- Place the 10-MHz reference out signal from the signal generator that is providing the DAC clock, and connect the signal to the LMK CLKIN SMA connector. [Figure 8](#) shows this connector highlighted by a red box.

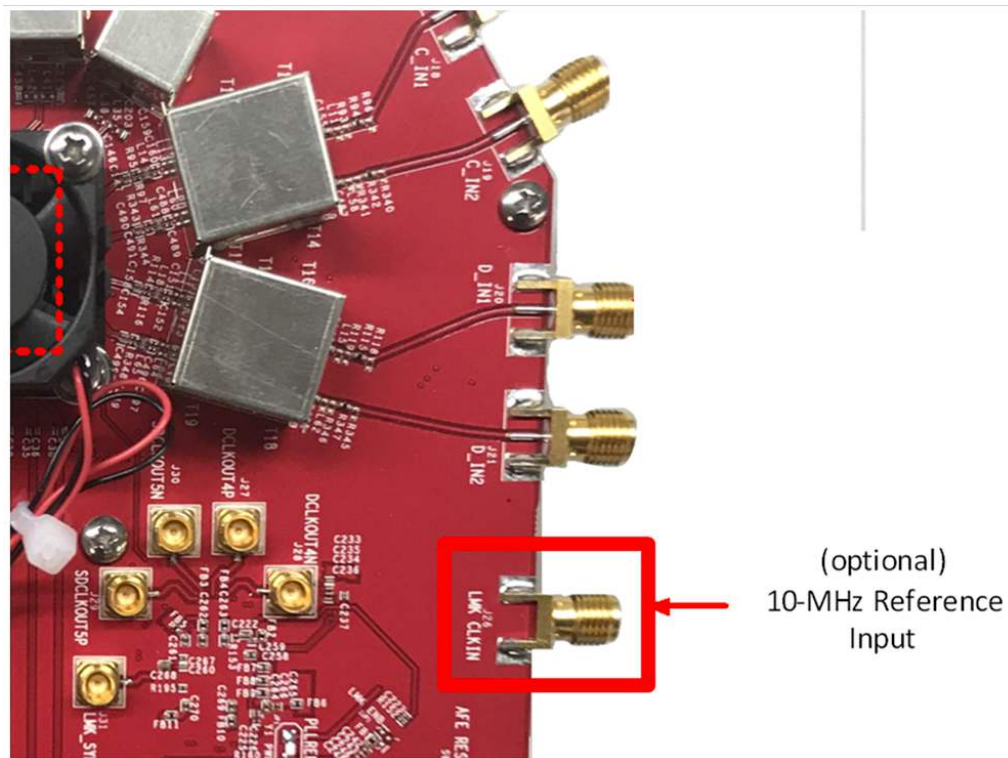

Figure 8. Optional Reference Clock Source Input Location

5.3.1.2 Program the AFE74xxEVM in External Mode

NOTE: To use an external clock, make sure JP9 is moved to position 1-2 (see [Figure 6](#)) and verify that AFE CLK signal source is turned off.

1. Run the AFE74xx EVM_76xx GUI as administrator. The quick start page shown in [Figure 9](#) appears.
2. Under *EVM Selection*, verify that the EVM name shown matches the EVM in operation, labeled as 2 in [Figure 9](#)

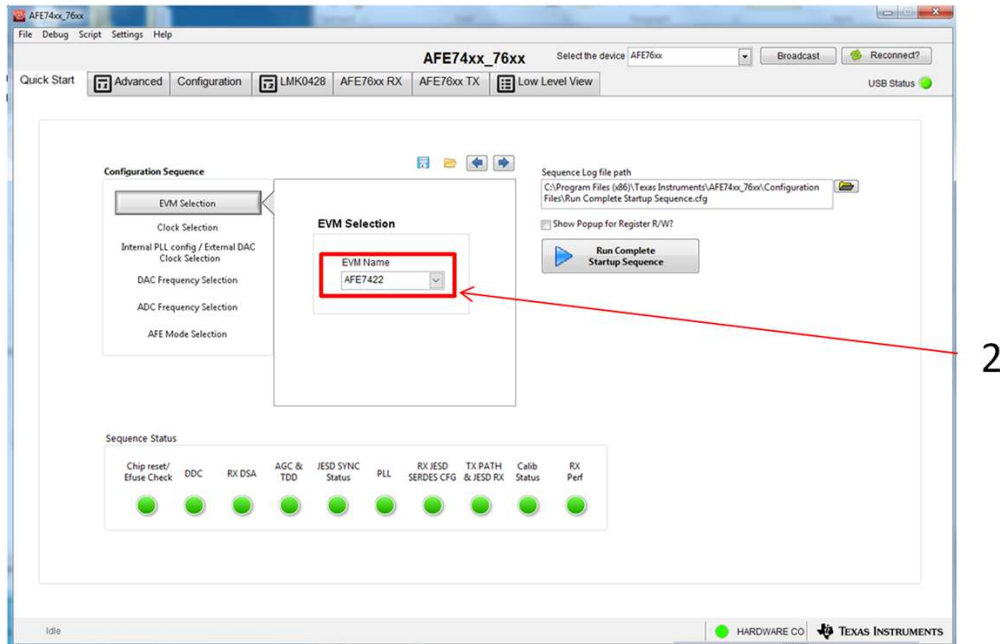

Figure 9. EVM Selection Page

3. Navigate to the *Clock Selection* page, labeled as 3 in [Figure 10](#)
4. Under the *CLK Option* drop-down menu, select *External CLK*, labeled as 4 in [Figure 10](#).

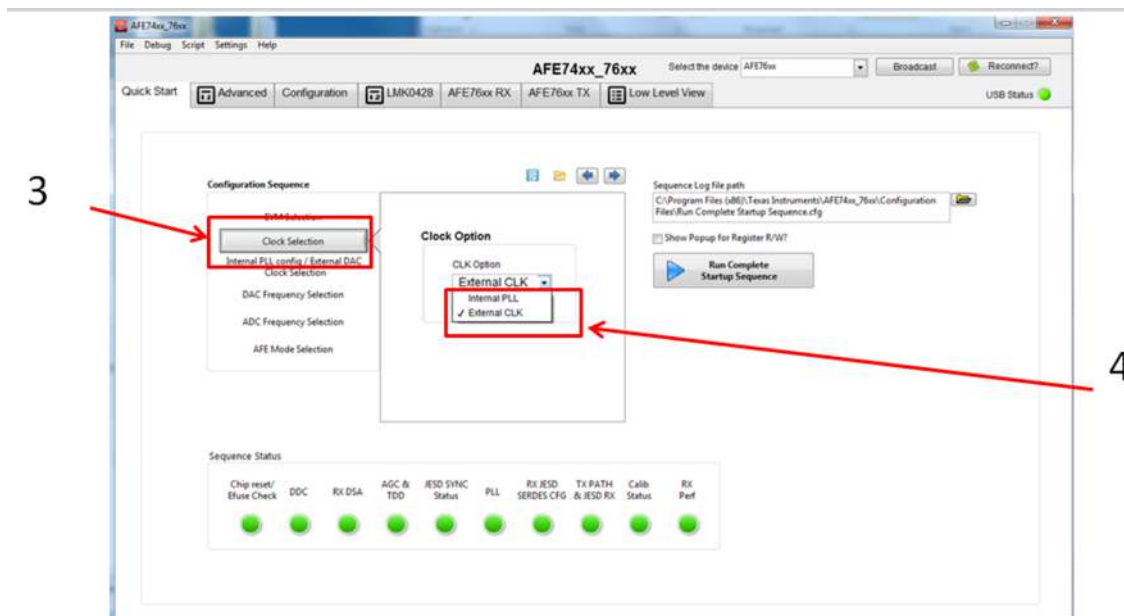

Figure 10. External Clock Selection Page

5. Navigate to the *Internal PLL config / External DAC Clock Selection* page, labeled as 5 in [Figure 11](#).
6. As shown by label 6 in [Figure 11](#), type in *8847.36* and press enter.

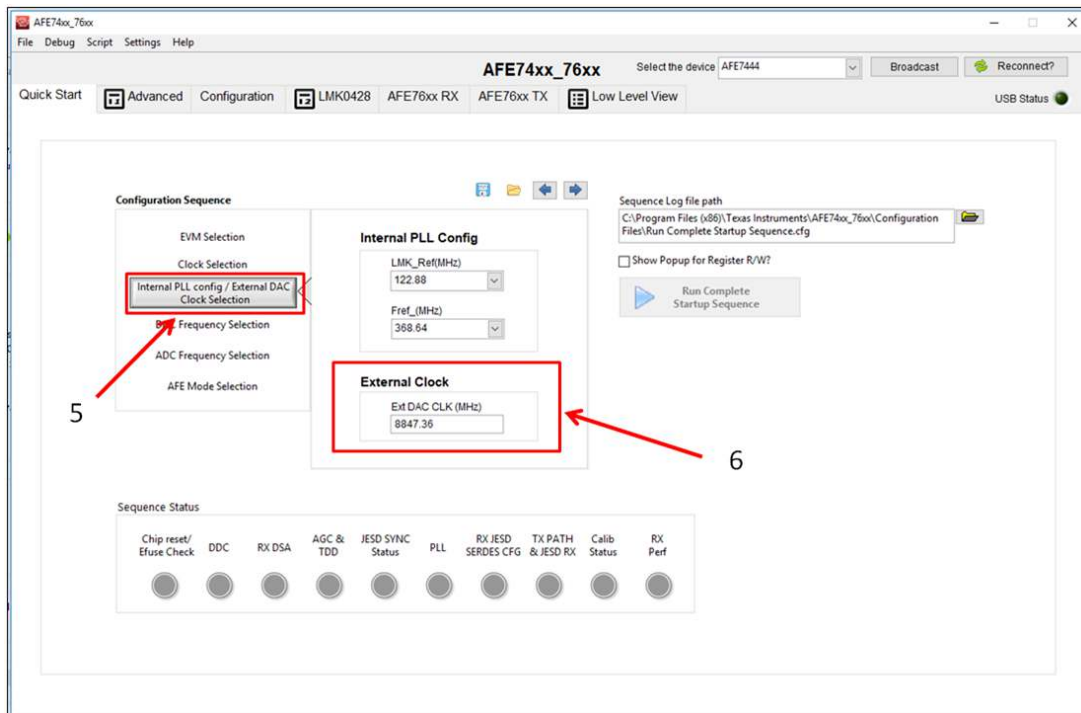

Figure 11. External DAC Clock Selection

7. Navigate to the *ADC Frequency Selection* page, labeled as 7 in [Figure 12](#).
8. Select a DIV value of 3, labeled as 8 in [Figure 12](#).

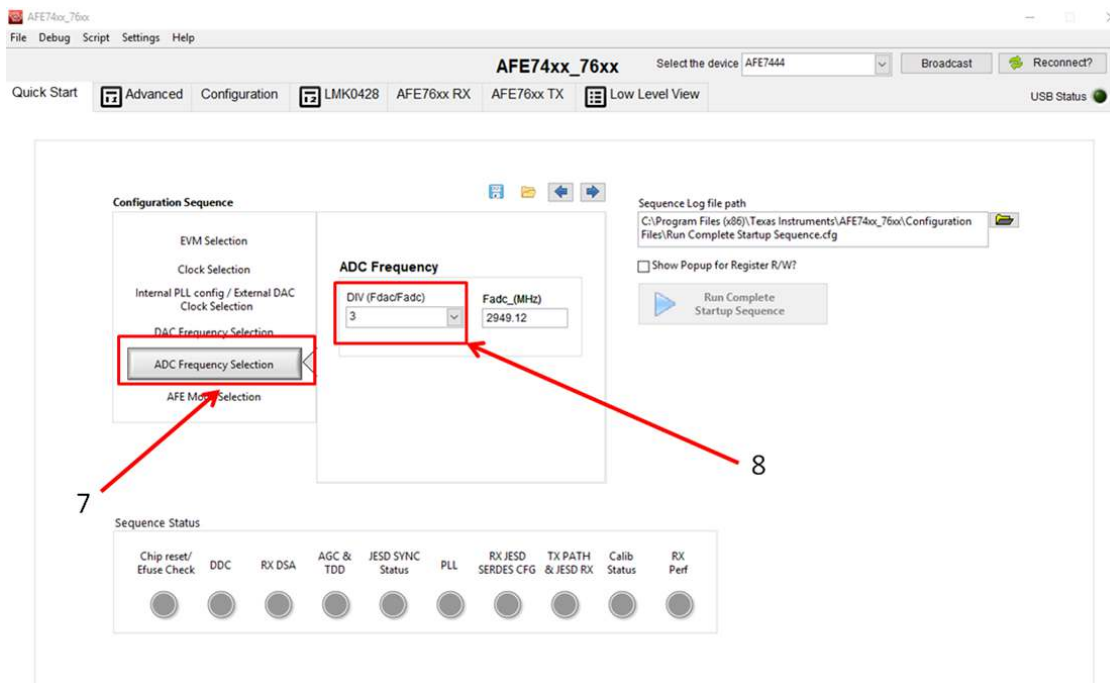

Figure 12. External Clock: ADC Clock Selection

9. Navigate to the *AFE Mode Selection* page, labeled as 9 in [Figure 13](#).
The *AFE EVM Mode Selection* page displays a list of the potential AFE74xxEVM configurations based on the previously selected inputs (Fdac, Fadc, and so on). The number displayed by the name is the digital bandwidth that the mode supports. Hover over the modes to see the details of each configuration, such as JESD204b settings, interpolation, decimation factor, and more. The grayed-out modes are not available.
10. Select *Mode 4 (600 MHz)*, labeled as 10 in [Figure 13](#).

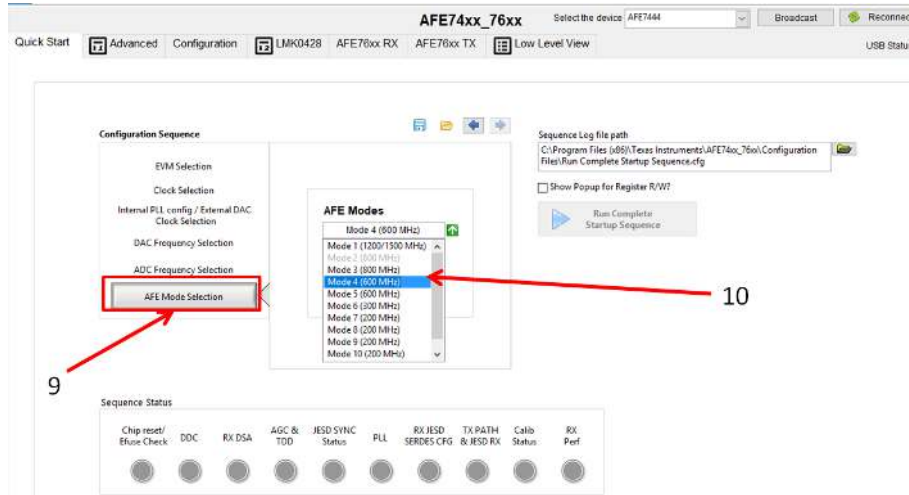

Figure 13. AFE Mode Selection Page

11. Click the *Set Mode* button, labeled as 11 in [Figure 14](#). *Set Mode* initializes the AFE74xxEVM and programs the LMK for the selected mode. Verify that the LMK on the EVM is locked by checking that LED D7 titled *LMK Lock* is illuminated.
 - a. Turn on the AFE external clock signal generator.
 - b. Navigate back to HSDC Pro and click *Send*, labeled as 5 in [Figure 5](#).
12. Click *Run Complete Startup Sequence*, labeled as 12 in [Figure 14](#). *Run Complete Startup Sequence* begins to program the AFE74xxEVM when pressed. Programming the AFE74xx EVM only takes a couple of seconds.

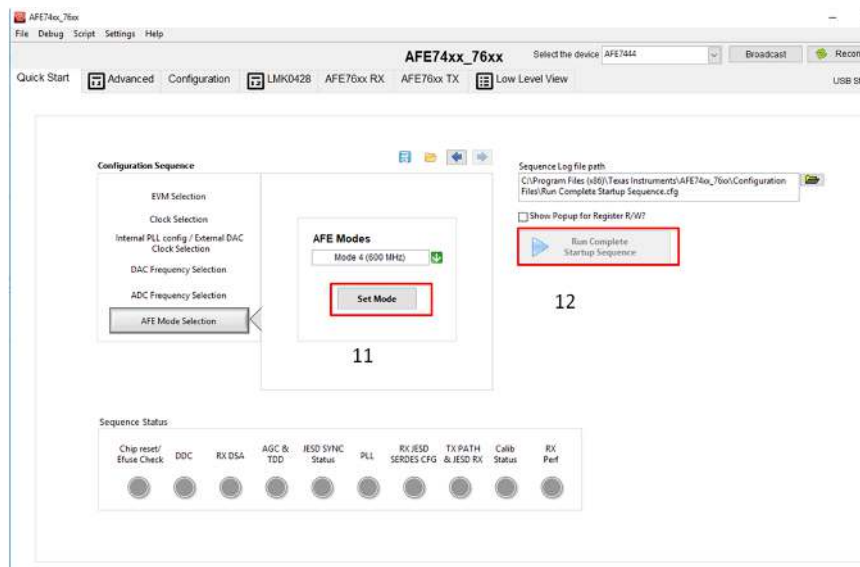

Figure 14. Set Mode and Run Complete Startup Sequence

13. After this process is complete, navigate to [Section 5.4](#), and read on from there.

5.3.2 Internal PLL Clock Mode

1. Run the AFE74xx EVM _76xx GUI as administrator. The quick-start page shown in [Figure 15](#) appears.
2. Under EVM Selection, verify that the EVM name matches the EVM in operation, shown by label 2 in [Figure 15](#).

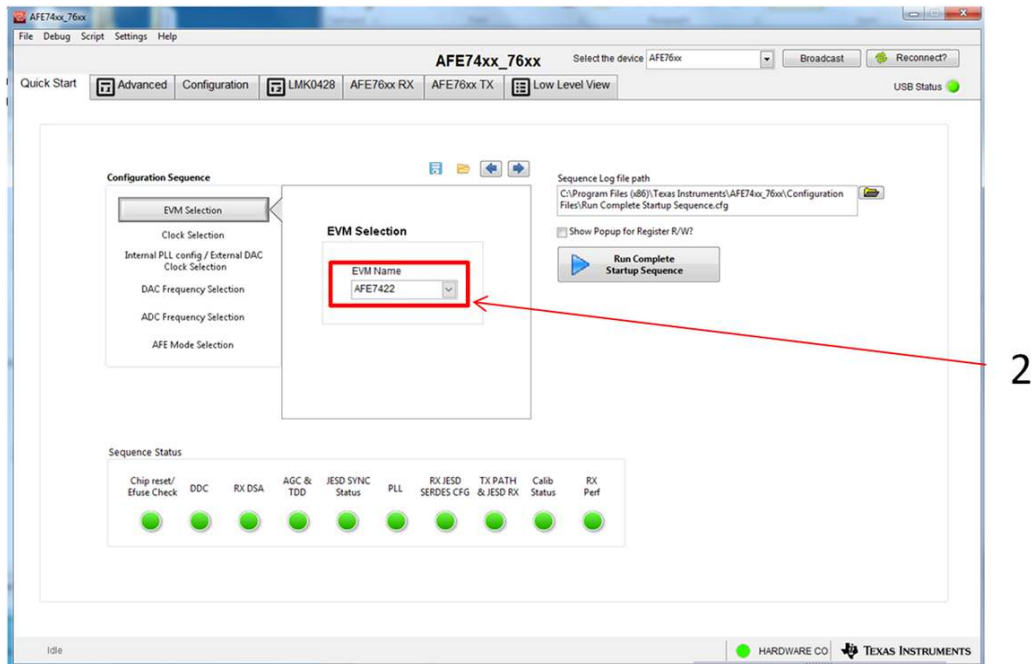

Figure 15. Quick-Start Page

3. Navigate to the *Clock Selection* page, labeled as 3 in [Figure 16](#). The *Clock Selection* page determines whether to clock the AFE74xxEVM with an external clock or use the internal PLL.
4. Select *Internal Clock* under the *CLK Option* drop-down menu, labeled as 4 in [Figure 16](#).

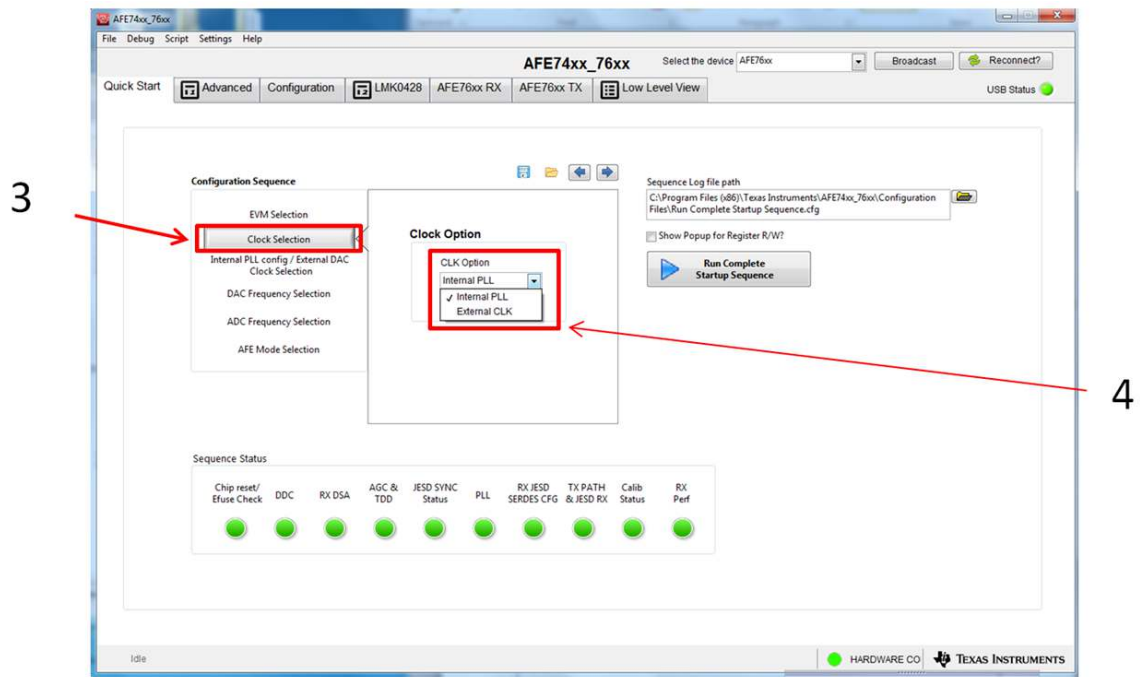

Figure 16. Clock Selection Page

5. Navigate to the *AFE Mode Selection* page, labeled as 5 in [Figure 17](#).
The *AFE Mode Selection* page displays a list of potential AFE74xxEVM configurations based on the selected Fdac and Fadc in the previous pages labeled *DAC Frequency Selection* and *ADC Frequency*. The number displayed by the name is the digital bandwidth that the mode supports. Hover over the modes to see the details of each configuration, such as JESD204b settings, interpolation, decimation factor, and so on. The grayed-out modes are not available.
6. Select Mode 4, shown as label 6 in [Figure 17](#).

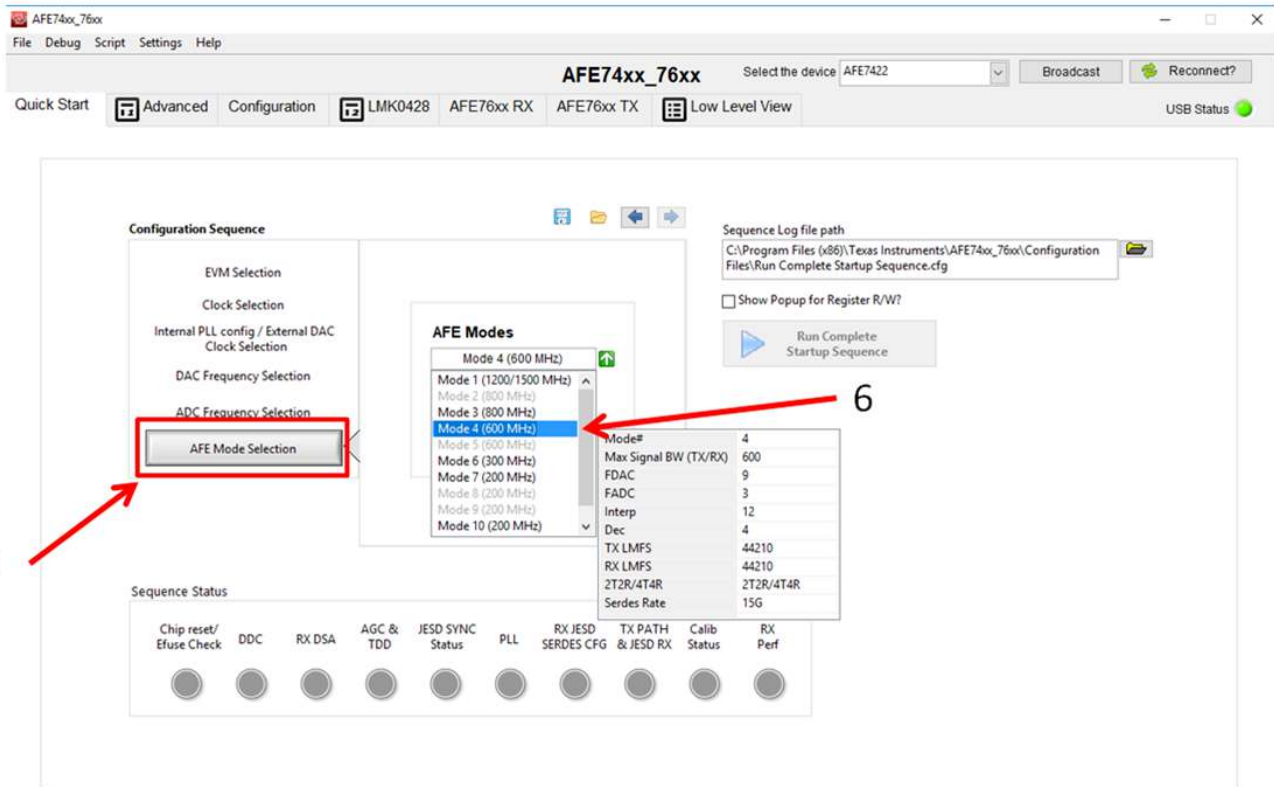

Figure 17. AFE Mode Selection Page Displaying Mode 4

7. After the GUI is finished programming, click *Set Mode*, labeled as 7 in [Figure 18](#). *Set Mode* initializes the AFE74xxEVM and programs the LMK for the selected mode. Verify that the LMK on the EVM is locked by checking that LED D7 titled *LMK Lock* is illuminated.
8. Navigate back to HSDC Pro and click *Send*, labeled as 5 in [Figure 5](#)
9. Click *Run Complete Startup Sequence*, labeled as 8 in [Figure 18](#). *Run Complete Startup Sequence* begins to program the AFE74xx EVM when pressed. Programming the AFE74xxEVM takes only a couple of seconds.

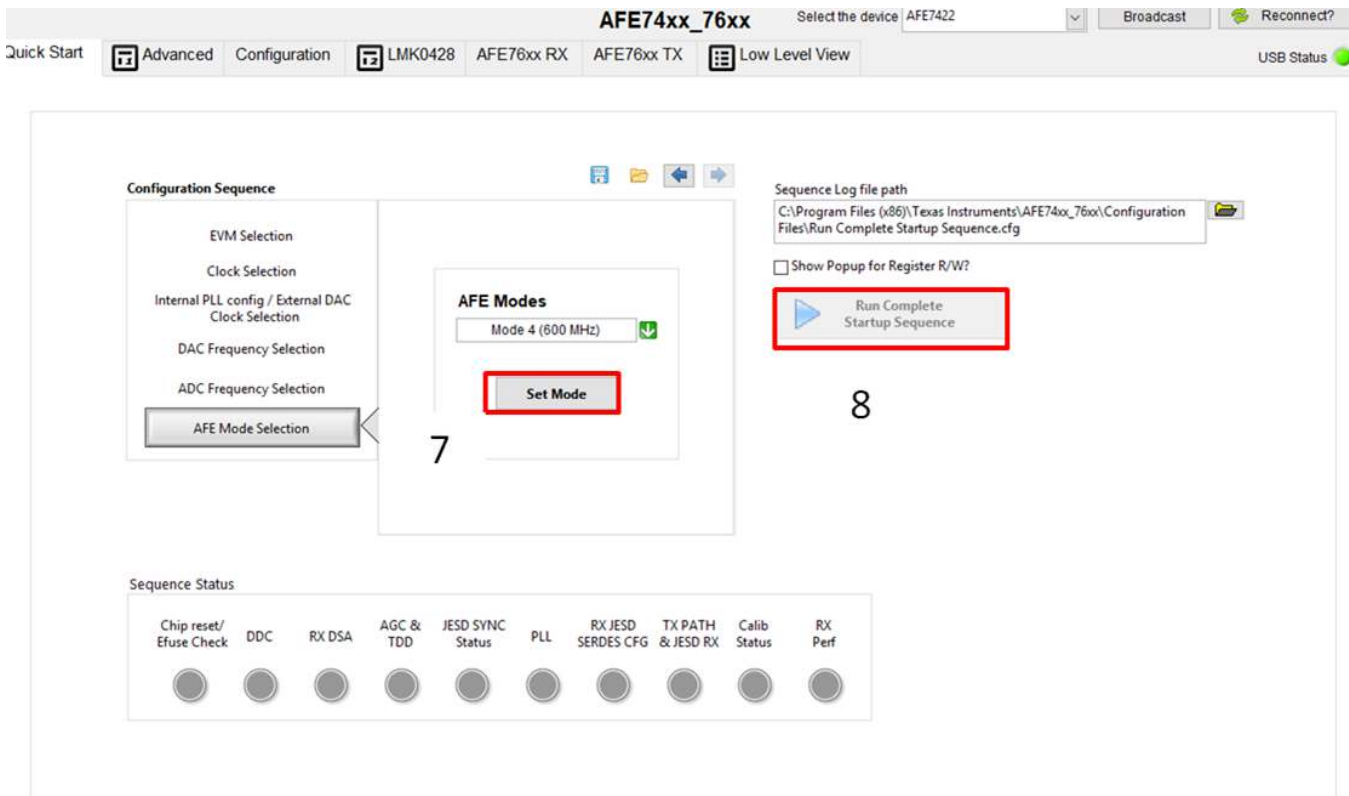

Figure 18. Set Mode and Run Complete Startup Sequence

At this point, green LEDs D6 and D7 are lit. D6 indicates that PLL loop 1 of the LMK04828 is locked. D7 indicates that PLL loop 2 of the LMK04828 is locked. The EVM is still functional without PLL loop 1 running, but PLL loop 2 is necessary for successful bringup.

- If PLL loop 1 is not running, check the 10-MHz reference. This is needed to achieve signal coherency with the signal generators and spectrum analyzer.
- If PLL loop 2 is not locked, contact TI applications for additional support.

5.4 Verify DAC Output on Spectrum Analyzer

Verify that the DAC is outputting two-tones centered at 1710 MHz and spaced 5 MHz apart on spectrum analyzer, as shown in Figure 19.

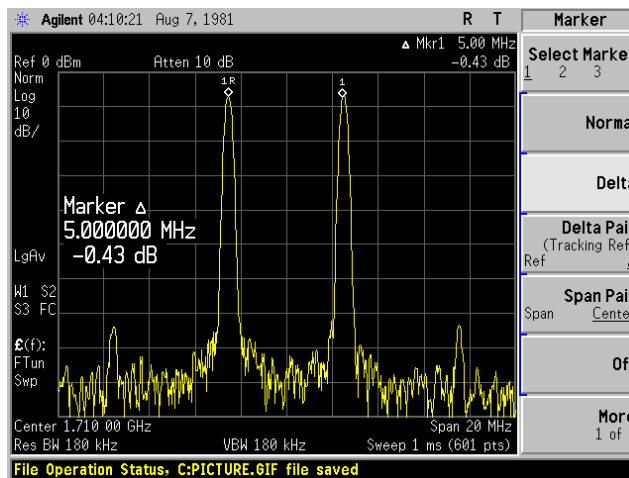

Figure 19. Two-Tone DAC Output Centered at 1710 MHz and Spaced 5 MHz Apart

5.4.1 AFE74xxEVM DAC Troubleshooting

1. If you do not see tones on the output, navigate back to the HSDC pro window and click the send button again. Check to see if the tones are now visible on the spectrum analyzer
2. If Step 1 does not work, navigate to the advanced panel in the GUI labeled 1 in Figure 20. Click the buttons labeled 2, 3, and 4 in that order. These buttons manually force a handshake of the JESD204B204B links. Check to see if the tones are now visible on the spectrum analyzer.

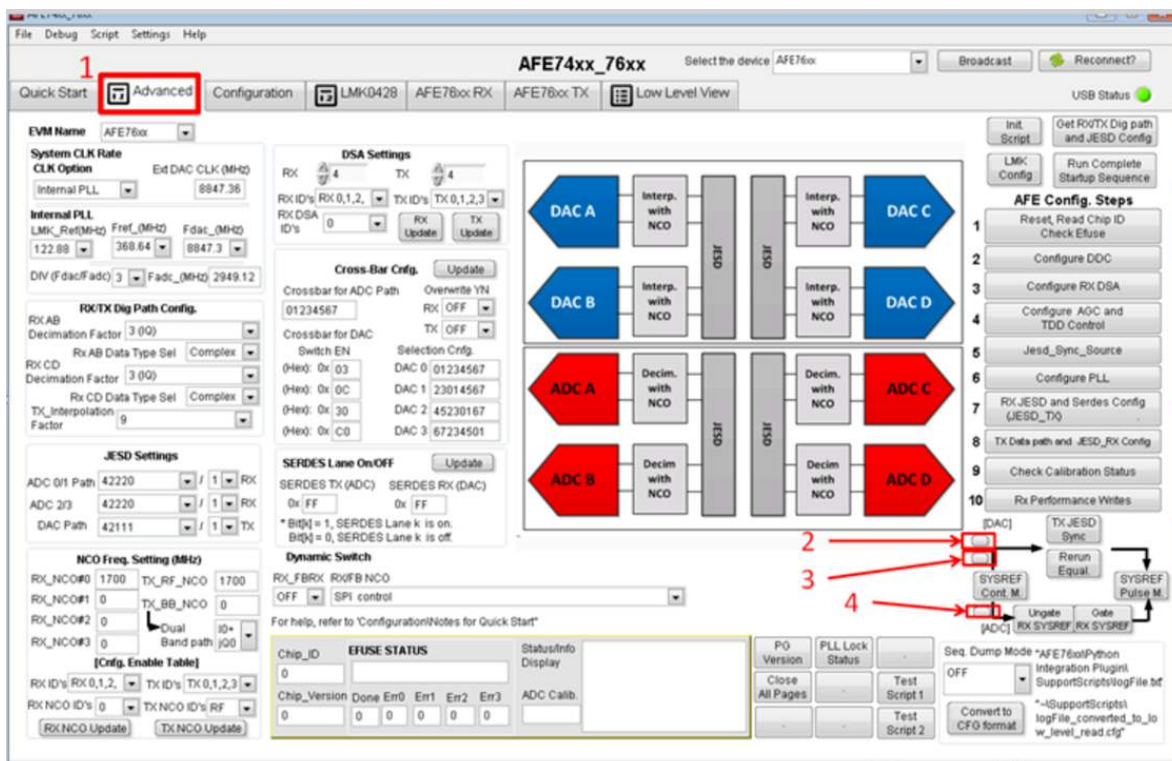

Figure 20. Troubleshooting the AFE74xxEVM DAC

5.5 Capture Tone

1. Switch back to the HSDC Pro window, select the ADC tab, and select the *AFE74xx_RX_Mode_4* file, shown as label 1 in Figure 21.
2. In the drop-down list that shows *Real FFT* selected by default, select the *Complex FFT* option.
3. Click the settings (gear) button located next to the *ADC Output Data Rate* field, and fill in the following parameters:
 - a. Check the enable box (label 2 in Figure 21)
 - b. ADC Sampling Rate = 2.94912G (label 3 in Figure 21)
 - c. ADC Input Frequency = 1.73G (label 4 in Figure 21)
 - d. NCO = -1.7G (label 5 in Figure 21)
 - e. Decimation = 4 (label 6 in Figure 21)
 - f. Press OK.
4. Verify that the ADC output data rate is 737.28M.
5. Click the *Capture* button located below the displayed ini file in Figure 21)

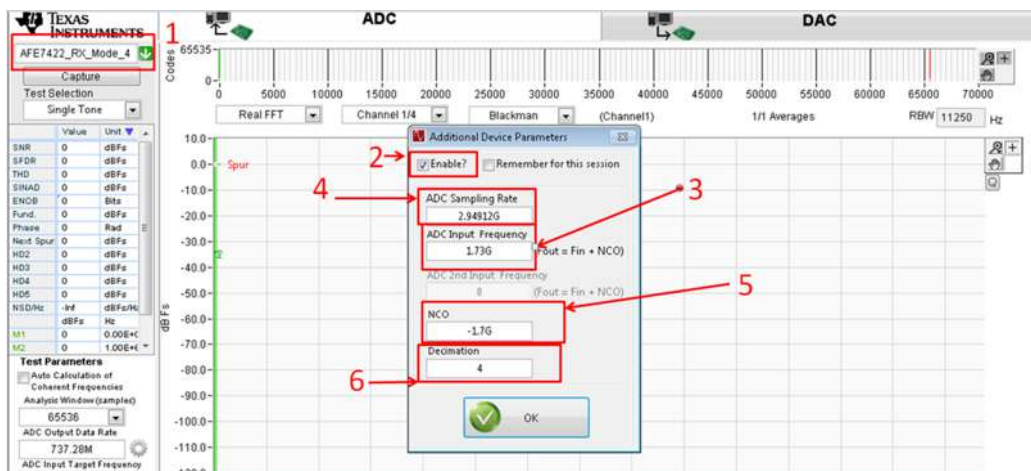

Figure 21. HSDC Pro ADC Settings

6. Verify that the tone is centered at 30 MHz, as shown in Figure 22.

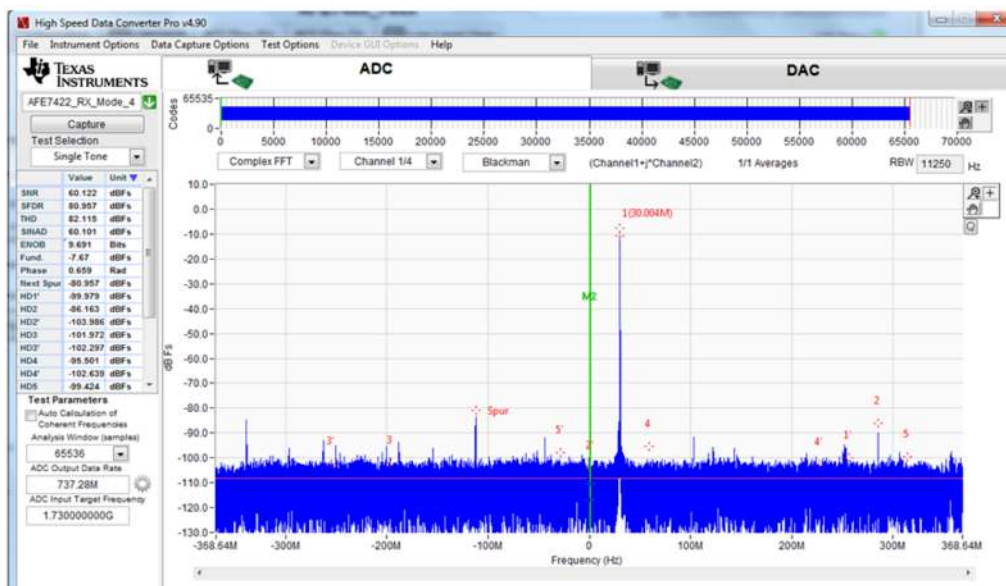

Figure 22. Tone Capture Centered at 30 MHz

5.6 AFE74xx NCO and DSA Settings

Figure 23 shows where the NCO and DSA settings are located in the GUI.

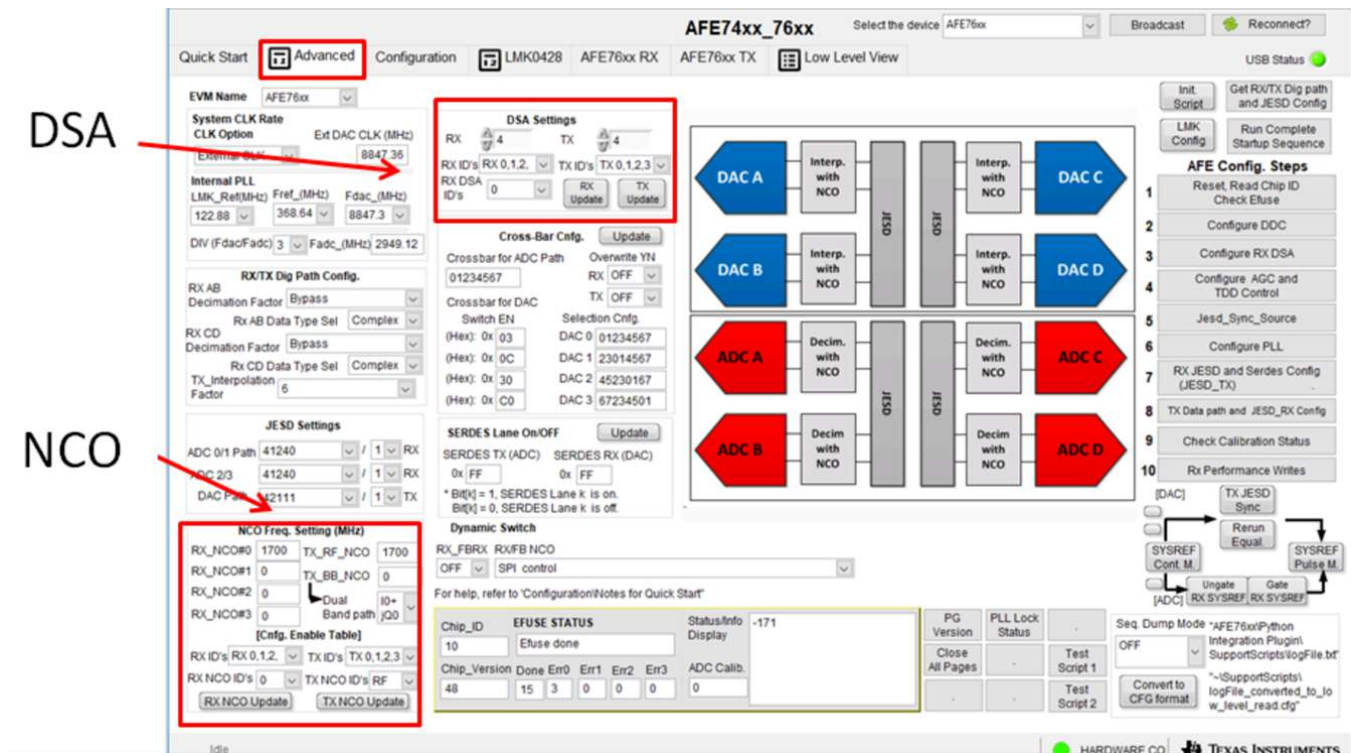

Figure 23. NCO and DSA Settings Location

5.6.1 Adjusting NCO

After a successful capture, the RX NCO can be adjusted using the *Advanced* tab. To change the RF frequency, enter a number in the *RX_RF_NCO* box, and click on the *RX NCO Update* button, shown in Figure 24.

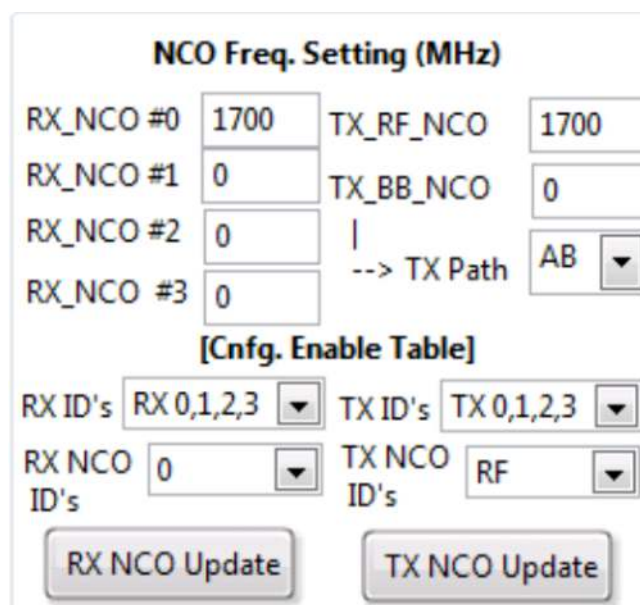

Figure 24. NCO Adjustment Settings

5.6.2 Adjusting DSA

After a successful capture, the RXDSA can be adjusted on *Advanced* tab page. To lower the RX power , enter a number at the RX DSA box, and click on the *RX Update* button shown in [Figure 25](#). The RX DSA has a range of 0 dB to 28 dB in 1-dB steps each. Enter the numbers in a dB scale.

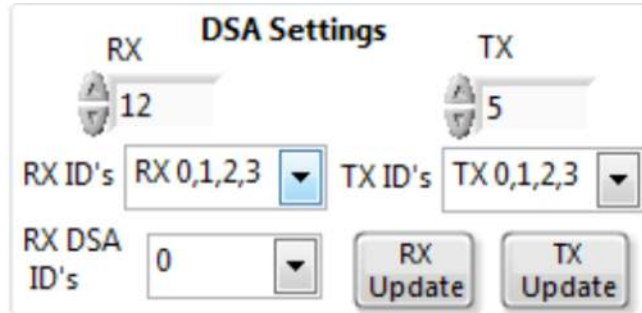

Figure 25. DSA Adjustment Settings

STANDARD TERMS FOR EVALUATION MODULES

1. *Delivery:* TI delivers TI evaluation boards, kits, or modules, including any accompanying demonstration software, components, and/or documentation which may be provided together or separately (collectively, an "EVM" or "EVMs") to the User ("User") in accordance with the terms set forth herein. User's acceptance of the EVM is expressly subject to the following terms.
 - 1.1 EVMs are intended solely for product or software developers for use in a research and development setting to facilitate feasibility evaluation, experimentation, or scientific analysis of TI semiconductor products. EVMs have no direct function and are not finished products. EVMs shall not be directly or indirectly assembled as a part or subassembly in any finished product. For clarification, any software or software tools provided with the EVM ("Software") shall not be subject to the terms and conditions set forth herein but rather shall be subject to the applicable terms that accompany such Software
 - 1.2 EVMs are not intended for consumer or household use. EVMs may not be sold, sublicensed, leased, rented, loaned, assigned, or otherwise distributed for commercial purposes by Users, in whole or in part, or used in any finished product or production system.
2. *Limited Warranty and Related Remedies/Disclaimers:*
 - 2.1 These terms do not apply to Software. The warranty, if any, for Software is covered in the applicable Software License Agreement.
 - 2.2 TI warrants that the TI EVM will conform to TI's published specifications for ninety (90) days after the date TI delivers such EVM to User. Notwithstanding the foregoing, TI shall not be liable for a nonconforming EVM if (a) the nonconformity was caused by neglect, misuse or mistreatment by an entity other than TI, including improper installation or testing, or for any EVMs that have been altered or modified in any way by an entity other than TI, (b) the nonconformity resulted from User's design, specifications or instructions for such EVMs or improper system design, or (c) User has not paid on time. Testing and other quality control techniques are used to the extent TI deems necessary. TI does not test all parameters of each EVM. User's claims against TI under this Section 2 are void if User fails to notify TI of any apparent defects in the EVMs within ten (10) business days after delivery, or of any hidden defects with ten (10) business days after the defect has been detected.
 - 2.3 TI's sole liability shall be at its option to repair or replace EVMs that fail to conform to the warranty set forth above, or credit User's account for such EVM. TI's liability under this warranty shall be limited to EVMs that are returned during the warranty period to the address designated by TI and that are determined by TI not to conform to such warranty. If TI elects to repair or replace such EVM, TI shall have a reasonable time to repair such EVM or provide replacements. Repaired EVMs shall be warranted for the remainder of the original warranty period. Replaced EVMs shall be warranted for a new full ninety (90) day warranty period.
3. *Regulatory Notices:*
 - 3.1 *United States*
 - 3.1.1 *Notice applicable to EVMs not FCC-Approved:*

FCC NOTICE: This kit is designed to allow product developers to evaluate electronic components, circuitry, or software associated with the kit to determine whether to incorporate such items in a finished product and software developers to write software applications for use with the end product. This kit is not a finished product and when assembled may not be resold or otherwise marketed unless all required FCC equipment authorizations are first obtained. Operation is subject to the condition that this product not cause harmful interference to licensed radio stations and that this product accept harmful interference. Unless the assembled kit is designed to operate under part 15, part 18 or part 95 of this chapter, the operator of the kit must operate under the authority of an FCC license holder or must secure an experimental authorization under part 5 of this chapter.
 - 3.1.2 *For EVMs annotated as FCC – FEDERAL COMMUNICATIONS COMMISSION Part 15 Compliant:*

CAUTION

This device complies with part 15 of the FCC Rules. Operation is subject to the following two conditions: (1) This device may not cause harmful interference, and (2) this device must accept any interference received, including interference that may cause undesired operation.

Changes or modifications not expressly approved by the party responsible for compliance could void the user's authority to operate the equipment.

FCC Interference Statement for Class A EVM devices

NOTE: This equipment has been tested and found to comply with the limits for a Class A digital device, pursuant to part 15 of the FCC Rules. These limits are designed to provide reasonable protection against harmful interference when the equipment is operated in a commercial environment. This equipment generates, uses, and can radiate radio frequency energy and, if not installed and used in accordance with the instruction manual, may cause harmful interference to radio communications. Operation of this equipment in a residential area is likely to cause harmful interference in which case the user will be required to correct the interference at his own expense.

FCC Interference Statement for Class B EVM devices

NOTE: This equipment has been tested and found to comply with the limits for a Class B digital device, pursuant to part 15 of the FCC Rules. These limits are designed to provide reasonable protection against harmful interference in a residential installation. This equipment generates, uses and can radiate radio frequency energy and, if not installed and used in accordance with the instructions, may cause harmful interference to radio communications. However, there is no guarantee that interference will not occur in a particular installation. If this equipment does cause harmful interference to radio or television reception, which can be determined by turning the equipment off and on, the user is encouraged to try to correct the interference by one or more of the following measures:

- Reorient or relocate the receiving antenna.
- Increase the separation between the equipment and receiver.
- Connect the equipment into an outlet on a circuit different from that to which the receiver is connected.
- Consult the dealer or an experienced radio/TV technician for help.

3.2 Canada

3.2.1 For EVMs issued with an Industry Canada Certificate of Conformance to RSS-210 or RSS-247

Concerning EVMs Including Radio Transmitters:

This device complies with Industry Canada license-exempt RSSs. Operation is subject to the following two conditions:

(1) this device may not cause interference, and (2) this device must accept any interference, including interference that may cause undesired operation of the device.

Concernant les EVMs avec appareils radio:

Le présent appareil est conforme aux CNR d'Industrie Canada applicables aux appareils radio exempts de licence. L'exploitation est autorisée aux deux conditions suivantes: (1) l'appareil ne doit pas produire de brouillage, et (2) l'utilisateur de l'appareil doit accepter tout brouillage radioélectrique subi, même si le brouillage est susceptible d'en compromettre le fonctionnement.

Concerning EVMs Including Detachable Antennas:

Under Industry Canada regulations, this radio transmitter may only operate using an antenna of a type and maximum (or lesser) gain approved for the transmitter by Industry Canada. To reduce potential radio interference to other users, the antenna type and its gain should be so chosen that the equivalent isotropically radiated power (e.i.r.p.) is not more than that necessary for successful communication. This radio transmitter has been approved by Industry Canada to operate with the antenna types listed in the user guide with the maximum permissible gain and required antenna impedance for each antenna type indicated. Antenna types not included in this list, having a gain greater than the maximum gain indicated for that type, are strictly prohibited for use with this device.

Concernant les EVMs avec antennes détachables

Conformément à la réglementation d'Industrie Canada, le présent émetteur radio peut fonctionner avec une antenne d'un type et d'un gain maximal (ou inférieur) approuvé pour l'émetteur par Industrie Canada. Dans le but de réduire les risques de brouillage radioélectrique à l'intention des autres utilisateurs, il faut choisir le type d'antenne et son gain de sorte que la puissance isotrope rayonnée équivalente (p.i.r.e.) ne dépasse pas l'intensité nécessaire à l'établissement d'une communication satisfaisante. Le présent émetteur radio a été approuvé par Industrie Canada pour fonctionner avec les types d'antenne énumérés dans le manuel d'usage et ayant un gain admissible maximal et l'impédance requise pour chaque type d'antenne. Les types d'antenne non inclus dans cette liste, ou dont le gain est supérieur au gain maximal indiqué, sont strictement interdits pour l'exploitation de l'émetteur.

3.3 Japan

3.3.1 *Notice for EVMs delivered in Japan:* Please see http://www.tij.co.jp/lstds/ti_ja/general/eStore/notice_01.page 日本国内に輸入される評価用キット、ボードについては、次のところをご覧ください。
http://www.tij.co.jp/lstds/ti_ja/general/eStore/notice_01.page

3.3.2 *Notice for Users of EVMs Considered "Radio Frequency Products" in Japan:* EVMs entering Japan may not be certified by TI as conforming to Technical Regulations of Radio Law of Japan.

If User uses EVMs in Japan, not certified to Technical Regulations of Radio Law of Japan, User is required to follow the instructions set forth by Radio Law of Japan, which includes, but is not limited to, the instructions below with respect to EVMs (which for the avoidance of doubt are stated strictly for convenience and should be verified by User):

1. Use EVMs in a shielded room or any other test facility as defined in the notification #173 issued by Ministry of Internal Affairs and Communications on March 28, 2006, based on Sub-section 1.1 of Article 6 of the Ministry's Rule for Enforcement of Radio Law of Japan,
2. Use EVMs only after User obtains the license of Test Radio Station as provided in Radio Law of Japan with respect to EVMs, or
3. Use of EVMs only after User obtains the Technical Regulations Conformity Certification as provided in Radio Law of Japan with respect to EVMs. Also, do not transfer EVMs, unless User gives the same notice above to the transferee. Please note that if User does not follow the instructions above, User will be subject to penalties of Radio Law of Japan.

【無線電波を送信する製品の開発キットをお使いになる際の注意事項】 開発キットの中には技術基準適合証明を受けていないものがあります。技術適合証明を受けていないものご使用に際しては、電波法遵守のため、以下のいずれかの措置を取っていただく必要がありますのでご注意ください。

1. 電波法施行規則第6条第1項第1号に基づく平成18年3月28日総務省告示第173号で定められた電波暗室等の試験設備でご使用いただく。
2. 実験局の免許を取得後ご使用いただく。
3. 技術基準適合証明を取得後ご使用いただく。

なお、本製品は、上記の「ご使用にあたっての注意」を譲渡先、移転先に通知しない限り、譲渡、移転できないものとします。

上記を遵守頂けない場合は、電波法の罰則が適用される可能性があることをご留意ください。日本テキサス・インスツルメンツ株式会社
東京都新宿区西新宿 6 丁目 2 4 番 1 号
西新宿三井ビル

3.3.3 *Notice for EVMs for Power Line Communication:* Please see http://www.tij.co.jp/llds/ti_ja/general/eStore/notice_02.page
電力線搬送波通信についての開発キットをお使いになる際の注意事項については、次のところをご覧ください。 http://www.tij.co.jp/llds/ti_ja/general/eStore/notice_02.page

3.4 *European Union*

3.4.1 *For EVMs subject to EU Directive 2014/30/EU (Electromagnetic Compatibility Directive):*

This is a class A product intended for use in environments other than domestic environments that are connected to a low-voltage power-supply network that supplies buildings used for domestic purposes. In a domestic environment this product may cause radio interference in which case the user may be required to take adequate measures.

4 *EVM Use Restrictions and Warnings:*

4.1 EVMS ARE NOT FOR USE IN FUNCTIONAL SAFETY AND/OR SAFETY CRITICAL EVALUATIONS, INCLUDING BUT NOT LIMITED TO EVALUATIONS OF LIFE SUPPORT APPLICATIONS.

4.2 User must read and apply the user guide and other available documentation provided by TI regarding the EVM prior to handling or using the EVM, including without limitation any warning or restriction notices. The notices contain important safety information related to, for example, temperatures and voltages.

4.3 *Safety-Related Warnings and Restrictions:*

4.3.1 User shall operate the EVM within TI's recommended specifications and environmental considerations stated in the user guide, other available documentation provided by TI, and any other applicable requirements and employ reasonable and customary safeguards. Exceeding the specified performance ratings and specifications (including but not limited to input and output voltage, current, power, and environmental ranges) for the EVM may cause personal injury or death, or property damage. If there are questions concerning performance ratings and specifications, User should contact a TI field representative prior to connecting interface electronics including input power and intended loads. Any loads applied outside of the specified output range may also result in unintended and/or inaccurate operation and/or possible permanent damage to the EVM and/or interface electronics. Please consult the EVM user guide prior to connecting any load to the EVM output. If there is uncertainty as to the load specification, please contact a TI field representative. During normal operation, even with the inputs and outputs kept within the specified allowable ranges, some circuit components may have elevated case temperatures. These components include but are not limited to linear regulators, switching transistors, pass transistors, current sense resistors, and heat sinks, which can be identified using the information in the associated documentation. When working with the EVM, please be aware that the EVM may become very warm.

4.3.2 EVMs are intended solely for use by technically qualified, professional electronics experts who are familiar with the dangers and application risks associated with handling electrical mechanical components, systems, and subsystems. User assumes all responsibility and liability for proper and safe handling and use of the EVM by User or its employees, affiliates, contractors or designees. User assumes all responsibility and liability to ensure that any interfaces (electronic and/or mechanical) between the EVM and any human body are designed with suitable isolation and means to safely limit accessible leakage currents to minimize the risk of electrical shock hazard. User assumes all responsibility and liability for any improper or unsafe handling or use of the EVM by User or its employees, affiliates, contractors or designees.

4.4 User assumes all responsibility and liability to determine whether the EVM is subject to any applicable international, federal, state, or local laws and regulations related to User's handling and use of the EVM and, if applicable, User assumes all responsibility and liability for compliance in all respects with such laws and regulations. User assumes all responsibility and liability for proper disposal and recycling of the EVM consistent with all applicable international, federal, state, and local requirements.

5. *Accuracy of Information:* To the extent TI provides information on the availability and function of EVMs, TI attempts to be as accurate as possible. However, TI does not warrant the accuracy of EVM descriptions, EVM availability or other information on its websites as accurate, complete, reliable, current, or error-free.

6. *Disclaimers:*
- 6.1 EXCEPT AS SET FORTH ABOVE, EVMS AND ANY MATERIALS PROVIDED WITH THE EVM (INCLUDING, BUT NOT LIMITED TO, REFERENCE DESIGNS AND THE DESIGN OF THE EVM ITSELF) ARE PROVIDED "AS IS" AND "WITH ALL FAULTS." TI DISCLAIMS ALL OTHER WARRANTIES, EXPRESS OR IMPLIED, REGARDING SUCH ITEMS, INCLUDING BUT NOT LIMITED TO ANY EPIDEMIC FAILURE WARRANTY OR IMPLIED WARRANTIES OF MERCHANTABILITY OR FITNESS FOR A PARTICULAR PURPOSE OR NON-INFRINGEMENT OF ANY THIRD PARTY PATENTS, COPYRIGHTS, TRADE SECRETS OR OTHER INTELLECTUAL PROPERTY RIGHTS.
- 6.2 EXCEPT FOR THE LIMITED RIGHT TO USE THE EVM SET FORTH HEREIN, NOTHING IN THESE TERMS SHALL BE CONSTRUED AS GRANTING OR CONFERRING ANY RIGHTS BY LICENSE, PATENT, OR ANY OTHER INDUSTRIAL OR INTELLECTUAL PROPERTY RIGHT OF TI, ITS SUPPLIERS/LICENSORS OR ANY OTHER THIRD PARTY, TO USE THE EVM IN ANY FINISHED END-USER OR READY-TO-USE FINAL PRODUCT, OR FOR ANY INVENTION, DISCOVERY OR IMPROVEMENT, REGARDLESS OF WHEN MADE, CONCEIVED OR ACQUIRED.
7. *USER'S INDEMNITY OBLIGATIONS AND REPRESENTATIONS.* USER WILL DEFEND, INDEMNIFY AND HOLD TI, ITS LICENSORS AND THEIR REPRESENTATIVES HARMLESS FROM AND AGAINST ANY AND ALL CLAIMS, DAMAGES, LOSSES, EXPENSES, COSTS AND LIABILITIES (COLLECTIVELY, "CLAIMS") ARISING OUT OF OR IN CONNECTION WITH ANY HANDLING OR USE OF THE EVM THAT IS NOT IN ACCORDANCE WITH THESE TERMS. THIS OBLIGATION SHALL APPLY WHETHER CLAIMS ARISE UNDER STATUTE, REGULATION, OR THE LAW OF TORT, CONTRACT OR ANY OTHER LEGAL THEORY, AND EVEN IF THE EVM FAILS TO PERFORM AS DESCRIBED OR EXPECTED.
8. *Limitations on Damages and Liability:*
- 8.1 *General Limitations.* IN NO EVENT SHALL TI BE LIABLE FOR ANY SPECIAL, COLLATERAL, INDIRECT, PUNITIVE, INCIDENTAL, CONSEQUENTIAL, OR EXEMPLARY DAMAGES IN CONNECTION WITH OR ARISING OUT OF THESE TERMS OR THE USE OF THE EVMS , REGARDLESS OF WHETHER TI HAS BEEN ADVISED OF THE POSSIBILITY OF SUCH DAMAGES. EXCLUDED DAMAGES INCLUDE, BUT ARE NOT LIMITED TO, COST OF REMOVAL OR REINSTALLATION, ANCILLARY COSTS TO THE PROCUREMENT OF SUBSTITUTE GOODS OR SERVICES, RETESTING, OUTSIDE COMPUTER TIME, LABOR COSTS, LOSS OF GOODWILL, LOSS OF PROFITS, LOSS OF SAVINGS, LOSS OF USE, LOSS OF DATA, OR BUSINESS INTERRUPTION. NO CLAIM, SUIT OR ACTION SHALL BE BROUGHT AGAINST TI MORE THAN TWELVE (12) MONTHS AFTER THE EVENT THAT GAVE RISE TO THE CAUSE OF ACTION HAS OCCURRED.
- 8.2 *Specific Limitations.* IN NO EVENT SHALL TI'S AGGREGATE LIABILITY FROM ANY USE OF AN EVM PROVIDED HEREUNDER, INCLUDING FROM ANY WARRANTY, INDEMNITY OR OTHER OBLIGATION ARISING OUT OF OR IN CONNECTION WITH THESE TERMS, , EXCEED THE TOTAL AMOUNT PAID TO TI BY USER FOR THE PARTICULAR EVM(S) AT ISSUE DURING THE PRIOR TWELVE (12) MONTHS WITH RESPECT TO WHICH LOSSES OR DAMAGES ARE CLAIMED. THE EXISTENCE OF MORE THAN ONE CLAIM SHALL NOT ENLARGE OR EXTEND THIS LIMIT.
9. *Return Policy.* Except as otherwise provided, TI does not offer any refunds, returns, or exchanges. Furthermore, no return of EVM(s) will be accepted if the package has been opened and no return of the EVM(s) will be accepted if they are damaged or otherwise not in a resalable condition. If User feels it has been incorrectly charged for the EVM(s) it ordered or that delivery violates the applicable order, User should contact TI. All refunds will be made in full within thirty (30) working days from the return of the components(s), excluding any postage or packaging costs.
10. *Governing Law:* These terms and conditions shall be governed by and interpreted in accordance with the laws of the State of Texas, without reference to conflict-of-laws principles. User agrees that non-exclusive jurisdiction for any dispute arising out of or relating to these terms and conditions lies within courts located in the State of Texas and consents to venue in Dallas County, Texas. Notwithstanding the foregoing, any judgment may be enforced in any United States or foreign court, and TI may seek injunctive relief in any United States or foreign court.

IMPORTANT NOTICE AND DISCLAIMER

TI PROVIDES TECHNICAL AND RELIABILITY DATA (INCLUDING DATASHEETS), DESIGN RESOURCES (INCLUDING REFERENCE DESIGNS), APPLICATION OR OTHER DESIGN ADVICE, WEB TOOLS, SAFETY INFORMATION, AND OTHER RESOURCES "AS IS" AND WITH ALL FAULTS, AND DISCLAIMS ALL WARRANTIES, EXPRESS AND IMPLIED, INCLUDING WITHOUT LIMITATION ANY IMPLIED WARRANTIES OF MERCHANTABILITY, FITNESS FOR A PARTICULAR PURPOSE OR NON-INFRINGEMENT OF THIRD PARTY INTELLECTUAL PROPERTY RIGHTS.

These resources are intended for skilled developers designing with TI products. You are solely responsible for (1) selecting the appropriate TI products for your application, (2) designing, validating and testing your application, and (3) ensuring your application meets applicable standards, and any other safety, security, or other requirements. These resources are subject to change without notice. TI grants you permission to use these resources only for development of an application that uses the TI products described in the resource. Other reproduction and display of these resources is prohibited. No license is granted to any other TI intellectual property right or to any third party intellectual property right. TI disclaims responsibility for, and you will fully indemnify TI and its representatives against, any claims, damages, costs, losses, and liabilities arising out of your use of these resources.

TI's products are provided subject to TI's Terms of Sale (www.ti.com/legal/termsofsale.html) or other applicable terms available either on ti.com or provided in conjunction with such TI products. TI's provision of these resources does not expand or otherwise alter TI's applicable warranties or warranty disclaimers for TI products.

Mailing Address: Texas Instruments, Post Office Box 655303, Dallas, Texas 75265
Copyright © 2018, Texas Instruments Incorporated