

FEATURES

- High accuracy; supports IEC 61036/60687, IEC62053-21, and IEC62053-22**
- On-chip digital integrator enables direct interface-to-current sensors with di/dt output**
- A PGA in the current channel allows direct interface to shunts and current transformers**
- Active and apparent energy, sampled waveform, and current and voltage rms**
- Less than 0.1% error in active energy measurement over a dynamic range of 1000 to 1 at 25°C**
- Positive-only energy accumulation mode available**
- On-chip user programmable threshold for line voltage surge and SAG and PSU supervisory**
- Digital calibration for power, phase, and input offset**
- On-chip temperature sensor ($\pm 3^\circ\text{C}$ typical)**
- SPI®-compatible serial interface**
- Pulse output with programmable frequency**
- Interrupt request pin ($\overline{\text{IRQ}}$) and status register**
- Reference 2.4 V with external overdrive capability**
- Single 5 V supply, low power (25 mW typical)**

GENERAL DESCRIPTION

The ADE7763¹ features proprietary ADCs and fixed function DSP for high accuracy over large variations in environmental conditions and time. The ADE7763 incorporates two second-order, 16-bit Σ - Δ ADCs, a digital integrator (on Ch1), reference circuitry, a temperature sensor, and all the signal processing required to

perform active and apparent energy measurements, line-voltage period measurements, and rms calculation on the voltage and current channels. The selectable on-chip digital integrator provides direct interface to di/dt current sensors such as Rogowski coils, eliminating the need for an external analog integrator and resulting in excellent long-term stability and precise phase matching between the current and the voltage channels.

The ADE7763 provides a serial interface to read data and a pulse output frequency (CF) that is proportional to the active power. Various system calibration features such as channel offset correction, phase calibration, and power calibration ensure high accuracy. The part also detects short duration, low or high voltage variations.

The positive-only accumulation mode gives the option to accumulate energy only when positive power is detected. An internal no-load threshold ensures that the part does not exhibit any creep when there is no load. The zero-crossing output (ZX) produces a pulse that is synchronized to the zero-crossing point of the line voltage. This signal is used internally in the line cycle active and apparent energy accumulation modes, which enables faster calibration.

The interrupt status register indicates the nature of the interrupt, and the interrupt enable register controls which event produces an output on the $\overline{\text{IRQ}}$ pin, an open-drain, active low logic output.

The ADE7763 is available in a 20-lead SSOP package.

FUNCTIONAL BLOCK DIAGRAM

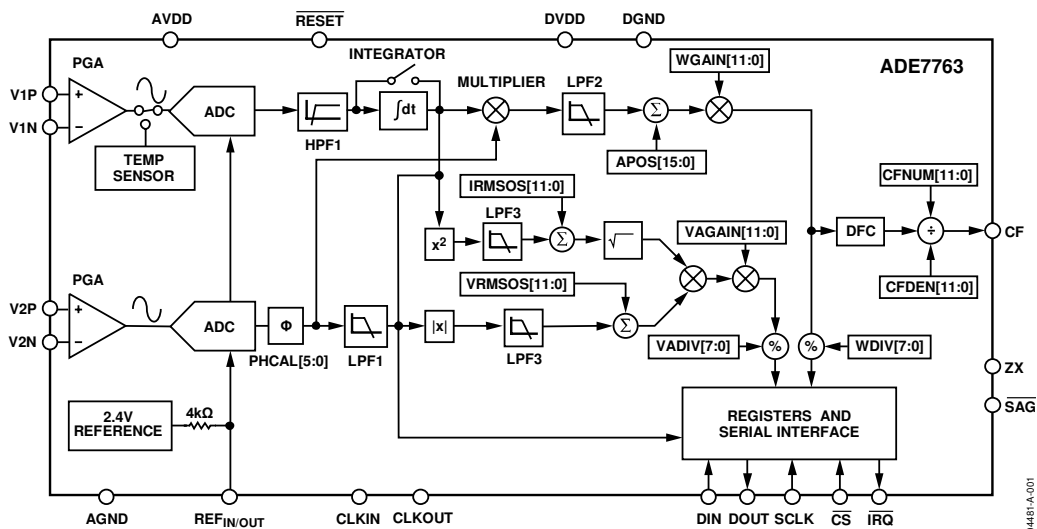

Figure 1.

¹U.S. Patents 5,745,323; 5,760,617; 5,862,069; 5,872,469.

Rev. C

Document Feedback

Information furnished by Analog Devices is believed to be accurate and reliable. However, no responsibility is assumed by Analog Devices for its use, nor for any infringements of patents or other rights of third parties that may result from its use. Specifications subject to change without notice. No license is granted by implication or otherwise under any patent or patent rights of Analog Devices. Trademarks and registered trademarks are the property of their respective owners.

TABLE OF CONTENTS

Features	1	Active Power Calculation	25
General Description	1	Energy Calculation.....	27
Functional Block Diagram	1	Power Offset Calibration.....	29
Revision History	3	Energy-to-Frequency Conversion.....	29
Specifications.....	4	Line Cycle Energy Accumulation Mode	31
Timing Characteristics	6	Positive-Only Accumulation Mode	31
Absolute Maximum Ratings.....	7	No-Load Threshold.....	31
ESD Caution.....	7	Apparent Power Calculation.....	32
Terminology	8	Apparent Energy Calculation	33
Pin Configuration and Function Descriptions.....	9	Line Apparent Energy Accumulation.....	34
Typical Performance Characteristics	11	Energies Scaling.....	35
Theory of Operation	14	Calibrating an Energy Meter	35
Analog Inputs.....	14	CLKIN Frequency	44
di/dt Current Sensor and Digital Integrator	15	Suspending Functionality.....	45
Zero-Crossing Detection	16	Checksum Register.....	45
Period Measurement	17	Serial Interface	45
Power Supply Monitor	17	Registers.....	48
Line Voltage Sag Detection	18	Register Descriptions	51
Peak Detection	18	Communication Register	51
Interrupts.....	19	Mode Register (0x09).....	51
Temperature Measurement	20	Interrupt Status Register (0x0B), Reset Interrupt Status Register (0x0C), Interrupt Enable Register (0x0A)	53
Analog-to-Digital Conversion.....	20	CH1OS Register (0x0D)	54
Channel 1 ADC	21	Outline Dimensions	55
Channel 2 ADC	23	Ordering Guide	55
Phase Compensation.....	24		

REVISION HISTORY**1/13—Rev. B to Rev. C**

Changes to Figure 1.....	1
Moved Revision History Section.....	3
Changes to Table 2	6
Changes to Table 4	9
Changes to Figure 24	14
Changes to Zero-Crossing Detection Section	16
Changes to Period Measurement Section	17
Changes to Peak Level Record Section.....	18
Change to Figure 37	19
Changes to Figure 43, Channel 1 Sampling Section, and Channel 1 RMS Calculation Section	22
Changes to Channel 1 RMS Offset Compensation Section and Channel 2 Sampling Section	23
Changes to Channel 2 RMS Calculation Section and Channel 2 RMS Offset Compensation Section	24
Changes to Energy Calculation Section	27
Changes to Power Offset Calibration Section	29
Changes to Positive-Only Accumulation Mode Section.....	31
Changes to Serial Interface Section	45
Changes to Table 9	48
Change to Table 12, Bit 1 Description	53
Changes to Ordering Guide.....	55

7/09—Rev. A to Rev. B

Changes to Zero Crossing Detection Section	15
Changes to Period Measurement Section	16
Changes to Channel 1 RMS Offset Calculation Section.....	22
Changes to Channel 1 RMS Offset Compensation Section	22
Changes to Figure 48	23
Changes to Channel 2 RMS Calculation Section.....	23
Changes to Table 11, Bit 15 Description	51
Changes to Table 12, Bit 4 Description	52

10/04—Data Sheet Changed from Rev. 0 to Rev. A

Changes to Period Measurement Section	16
Changes to Temperature Measurement Section	19
Change to Energy-to-Frequency Conversion Section	28
Update to Figure 61.....	29
Change to Apparent Energy Calculation Section	32
Change to Description of AEHF and VAEHF Bits.....	52
Changes to Ordering Guide.....	54

4/04—Revision 0: Initial Version

SPECIFICATIONS

AV_{DD} = DV_{DD} = 5 V ± 5%, AGND = DGND = 0 V, on-chip reference, CLKIN = 3.579545 MHz XTAL, T_{MIN} to T_{MAX} = -40°C to +85°C.

Table 1. Specifications^{1, 2}

Parameter	Spec	Unit	Test Conditions/Comments
ENERGY MEASUREMENT ACCURACY			
Active Power Measurement Error			
Channel 1 Range = 0.5 V Full Scale			
Gain = 1	0.1	% typ	CLKIN = 3.579545 MHz Channel 2 = 300 mV rms/60 Hz, gain = 2 Over a dynamic range 1000 to 1
Gain = 2	0.1	% typ	Over a dynamic range 1000 to 1
Gain = 4	0.1	% typ	Over a dynamic range 1000 to 1
Gain = 8	0.1	% typ	Over a dynamic range 1000 to 1
Channel 1 Range = 0.25 V Full Scale			
Gain = 1	0.1	% typ	Over a dynamic range 1000 to 1
Gain = 2	0.1	% typ	Over a dynamic range 1000 to 1
Gain = 4	0.1	% typ	Over a dynamic range 1000 to 1
Gain = 8	0.2	% typ	Over a dynamic range 1000 to 1
Channel 1 Range = 0.125 V Full Scale			
Gain = 1	0.1	% typ	Over a dynamic range 1000 to 1
Gain = 2	0.1	% typ	Over a dynamic range 1000 to 1
Gain = 4	0.2	% typ	Over a dynamic range 1000 to 1
Gain = 8	0.2	% typ	Over a dynamic range 1000 to 1
Active Power Measurement Bandwidth	14	kHz	
Phase Error 1 between Channels	±0.05	max	Line frequency = 45 Hz to 65 Hz, HPF on
AC Power Supply Rejection ¹			
Output Frequency Variation (CF)	0.2	% typ	AVDD = DVDD = 5 V + 175 mV rms/120 Hz Channel 1 = 20 mV rms, gain = 16, range = 0.5 V Channel 2 = 300 mV rms/60 Hz, gain = 1
DC Power Supply Rejection ¹			
Output Frequency Variation (CF)	±0.3	% typ	AVDD = DVDD = 5 V ± 250 mV dc Channel 1 = 20 mV rms/60 Hz, gain = 16, range = 0.5 V Channel 2 = 300 mV rms/60 Hz, gain = 1
IRMS Measurement Error	0.5	% typ	Over a dynamic range 100 to 1
IRMS Measurement Bandwidth	14	kHz	
VRMS Measurement Error	0.5	% typ	Over a dynamic range 20 to 1
VRMS Measurement Bandwidth	140	Hz	
ANALOG INPUTS³			
Maximum Signal Levels	±0.5	V max	See the Analog Inputs section
Input Impedance (dc)	390	k min	V1P, V1N, V2N, and V2P to AGND
Bandwidth	14	kHz	CLKIN/256, CLKIN = 3.579545 MHz
Gain Error ^{1, 3}			
Channel 1			
Range = 0.5 V Full Scale	±4	% typ	V1 = 0.5 V dc
Range = 0.25 V Full Scale	±4	% typ	V1 = 0.25 V dc
Range = 0.125 V Full Scale	±4	% typ	V1 = 0.125 V dc
Channel 2			
	±4	% typ	V2 = 0.5 V dc
Offset Error 1			
Channel 1			
	±32	mV max	Gain 1
	±13	mV max	Gain 16
Channel 2			
	±32	mV max	Gain 1
	±13	mV max	Gain 16
WAVEFORM SAMPLING			
Channel 1			
Signal-to-Noise Plus Distortion	62	dB typ	Sampling CLKIN/128, 3.579545 MHz/128 = 27.9 kSPS See the Channel 1 Sampling section
Bandwidth (-3 dB)	14	kHz	150 mV rms/60 Hz, range = 0.5 V, gain = 2 CLKIN = 3.579545 MHz
Channel 2			
Signal-to-Noise Plus Distortion	60	dB typ	See the Channel 2 Sampling section
Bandwidth (-3 dB)	140	Hz	150 mV rms/60 Hz, gain = 2 CLKIN = 3.579545 MHz

Parameter	Spec	Unit	Test Conditions/Comments
REFERENCE INPUT			
REF _{IN/OUT} Input Voltage Range	2.6 2.2	V max V min	2.4 V + 8% 2.4 V – 8%
Input Capacitance	10	pF max	
ON-CHIP REFERENCE			Nominal 2.4 V at REF _{IN/OUT} pin
Reference Error	±200	mV max	
Current Source	10	µA max	
Output Impedance	3.4	kΩ min	
Temperature Coefficient	30	ppm/°C typ	
CLKIN			All specifications CLKIN of 3.579545 MHz
Input Clock Frequency	4 1	MHz max MHz min	
LOGIC INPUTS			
RESET, DIN, SCLK, CLKIN, and CS			
Input High Voltage, V _{INH}	2.4	V min	DVDD = 5 V ± 10%
Input Low Voltage, V _{INL}	0.8	V max	DVDD = 5 V ± 10%
Input Current, I _{IN}	±3	µA max	Typically 10 nA, V _{IN} = 0 V to DVDD
Input Capacitance, C _{IN}	10	pF max	
LOGIC OUTPUTS			
SAG and IRQ			Open-drain outputs, 10 kΩ pull-up resistor
Output High Voltage, V _{OH}	4	V min	I _{SOURCE} = 5 mA
Output Low Voltage, V _{OL}	0.4	V max	I _{SINK} = 0.8 mA
ZX and DOUT			
Output High Voltage, V _{OH}	4	V min	I _{SOURCE} = 5 mA
Output Low Voltage, V _{OL}	0.4	V max	I _{SINK} = 0.8 mA
CF			
Output High Voltage, V _{OH}	4	V min	I _{SOURCE} = 5 mA
Output Low Voltage, V _{OL}	1	V max	I _{SINK} = 7 mA
POWER SUPPLY			For specified performance
AVDD	4.75 5.25	V min V max	5 V – 5% 5 V + 5%
DVDD	4.75 5.25	V min V max	5 V – 5% 5 V + 5%
AIDD	3	mA max	Typically 2.0 mA
DIDD	4	mA max	Typically 3.0 mA

¹ See the Terminology section for explanation of specifications.
² See the plots in the Typical Performance Characteristics section.
³ See the Analog Inputs section.

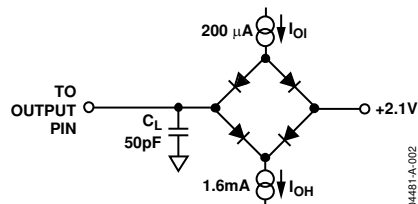

Figure 2. Load Circuit for Timing Specifications

TIMING CHARACTERISTICS

$AV_{DD} = DV_{DD} = 5 V \pm 5\%$, $AGND = DGND = 0 V$, on-chip reference, $CLKIN = 3.579545 MHz XTAL$, T_{MIN} to $T_{MAX} = -40^{\circ}C$ to $+85^{\circ}C$.

Table 2. Timing Characteristics^{1,2}

Parameter	Spec	Unit	Test Conditions/Comments
Write Timing			
t_1	50	ns min	\overline{CS} falling edge to first SCLK falling edge.
t_2	50	ns min	SCLK logic high pulse width.
t_3	50	ns min	SCLK logic low pulse width.
t_4	10	ns min	Valid data setup time before falling edge of SCLK.
t_5	5	ns min	Data hold time after SCLK falling edge.
t_6	4	μs min	Minimum time between the end of data byte transfers.
t_7	3200	ns min	Minimum time between byte transfers during a serial write.
t_8	100	ns min)	\overline{CS} hold time after SCLK falling edge.
Read Timing			
t_9^3	4	μs min	Minimum time between read command (i.e., a write to communication register) and data read.
t_{10}	50	ns min	Minimum time between data byte transfers during a multibyte read.
t_{11}	30	ns min	Data access time after SCLK rising edge following a write to the communication register.
t_{12}^4	100	ns max	Bus relinquish time after falling edge of SCLK.
	10	ns min	
t_{13}^5	100	ns max	Bus relinquish time after rising edge of \overline{CS} .
	10	ns min	

¹ Sample tested during initial release and after any redesign or process change that could affect this parameter. All input signals are specified with $t_r = t_f = 5 ns$ (10% to 90%) and timed from a voltage level of 1.6 V.

² See Figure 3, Figure 4, and the Serial Interface section.

³ Minimum time between read command and data read for all registers except waveform register, which is $t_9 = 500 ns$ min.

⁴ Measured with the load circuit in Figure 2 and defined as the time required for the output to cross 0.8 V or 2.4 V.

⁵ Derived from the measured time taken by the data outputs to change 0.5 V when loaded with the circuit in Figure 2. The measured number is then extrapolated back to remove the effects of charging or discharging the 50 pF capacitor. This means that the time quoted in the timing characteristics is the true bus relinquish time of the part and is independent of the bus loading.

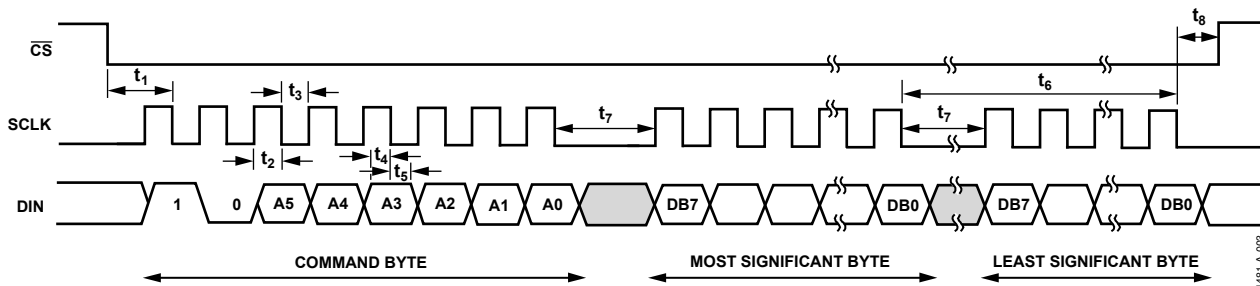

Figure 3. Serial Write Timing

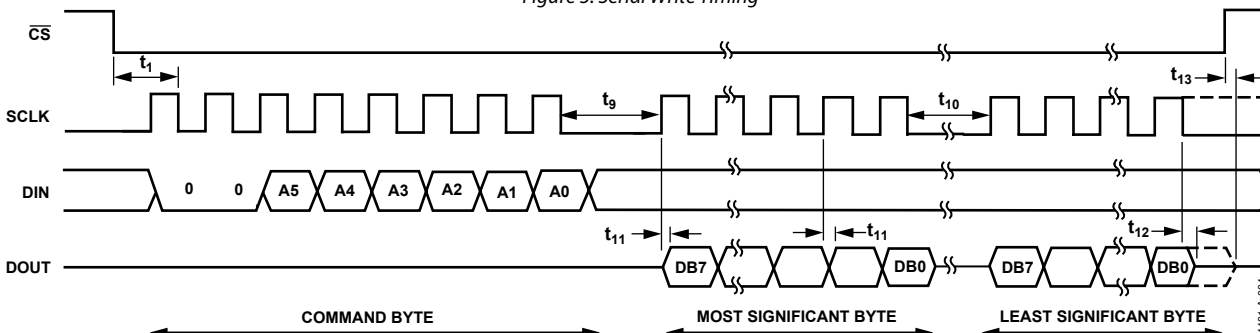

Figure 4. Serial Read Timing

ABSOLUTE MAXIMUM RATINGS

$T_A = 25^\circ\text{C}$, unless otherwise noted.

Table 3.

Parameter	Rating
AVDD to AGND	-0.3 V to +7 V
DVDD to DGND	-0.3 V to +7 V
DVDD to AVDD	-0.3 V to +0.3 V
Analog Input Voltage to AGND V1P, V1N, V2P, and V2N	-6 V to +6 V
Reference Input Voltage to AGND	-0.3 V to AVDD + 0.3 V
Digital Input Voltage to DGND	-0.3 V to DVDD + 0.3 V
Digital Output Voltage to DGND	-0.3 V to DVDD + 0.3 V
Operating Temperature Range	
Industrial	-40°C to +85°C
Storage Temperature Range	-65°C to +150°C
Junction Temperature	150°C
20-Lead SSOP, Power Dissipation	450 mW
θ_{JA} Thermal Impedance	112°C/W
Lead Temperature, Soldering	
Vapor Phase (60 s)	215°C
Infrared (15 s)	220°C

Stresses above those listed under Absolute Maximum Ratings may cause permanent damage to the device. This is a stress rating only, and functional operation of the device at these or any other conditions above those indicated in the operational section of this specification is not implied. Exposure to absolute maximum rating conditions for extended periods may affect device reliability.

ESD CAUTION

ESD (electrostatic discharge) sensitive device. Electrostatic charges as high as 4000 V readily accumulate on the human body and test equipment and can discharge without detection. Although this product features proprietary ESD protection circuitry, permanent damage may occur on devices subjected to high energy electrostatic discharges. Therefore, proper ESD precautions are recommended to avoid performance degradation or loss of functionality.



TERMINOLOGY

Measurement Error

The error associated with the energy measurement made by the ADE7763 is defined by the following formula:

$$\text{Percent Error} = \left(\frac{\text{Energy Register ADE7763} - \text{True Energy}}{\text{True Energy}} \right) \times 100\%$$

Phase Error between Channels

The digital integrator and the high-pass filter (HPF) in Channel 1 have a nonideal phase response. To offset this phase response and equalize the phase response between channels, two phase-correction networks are placed in Channel 1: one for the digital integrator and the other for the HPF. The phase correction networks correct the phase response of the corresponding component and ensure a phase match between Channel 1 (current) and Channel 2 (voltage) to within $\pm 0.1^\circ$ over a range of 45 Hz to 65 Hz with the digital integrator off. With the digital integrator on, the phase is corrected to within $\pm 0.4^\circ$ over a range of 45 Hz to 65 Hz.

Power Supply Rejection

This quantifies the ADE7763 measurement error as a percentage of the reading when the power supplies are varied. For the ac PSR measurement, a reading at nominal supplies (5 V) is taken. A second reading is obtained with the same input signal levels

when an ac (175 mV rms/120 Hz) signal is introduced to the supplies. Any error introduced by this ac signal is expressed as a percentage of the reading—see the Measurement Error definition.

For the dc PSR measurement, a reading at nominal supplies (5 V) is taken. A second reading is obtained with the same input signal levels when the supplies are varied $\pm 5\%$. Any error introduced is again expressed as a percentage of the reading.

ADC Offset Error

The dc offset associated with the analog inputs to the ADCs. It means that with the analog inputs connected to AGND, the ADCs still see a dc analog input signal. The magnitude of the offset depends on the gain and input range selection—see the Typical Performance Characteristics section. However, when HPF1 is switched on, the offset is removed from Channel 1 (current) and the power calculation is not affected by this offset. The offsets can be removed by performing an offset calibration—see the Analog Inputs section.

Gain Error

The difference between the measured ADC output code (minus the offset) and the ideal output code—see the Channel 1 ADC and Channel 2 ADC sections. It is measured for each of the input ranges on Channel 1 (0.5 V, 0.25 V, and 0.125 V). The difference is expressed as a percentage of the ideal code.

PIN CONFIGURATION AND FUNCTION DESCRIPTIONS

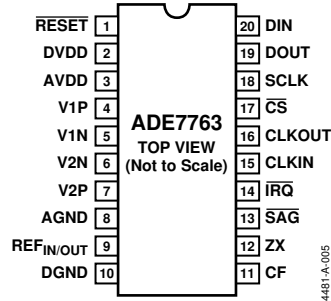

Figure 5. Pin Configuration (SSOP Package)

Table 4. Pin Function Descriptions

Pin No.	Mnemonic	Description
1	RESET	Reset Pin ¹ . A logic low on this pin holds the ADCs and digital circuitry (including the serial interface) in a reset condition.
2	DVDD	Digital Power Supply. This pin provides the supply voltage for the digital circuitry. The supply voltage should be maintained at $5\text{ V} \pm 5\%$ for specified operation. This pin should be decoupled to DGND with a $10\ \mu\text{F}$ capacitor in parallel with a ceramic $100\ \text{nF}$ capacitor.
3	AVDD	Analog Power Supply. This pin provides the supply voltage for the analog circuitry. The supply should be maintained at $5\text{ V} \pm 5\%$ for specified operation. Minimize power supply ripple and noise at this pin by using proper decoupling. The typical performance graphs show the power supply rejection performance. This pin should be decoupled to AGND with a $10\ \mu\text{F}$ capacitor in parallel with a ceramic $100\ \text{nF}$ capacitor.
4, 5	V1P, V1N	Analog Inputs for Channel 1. This channel is intended for use with a di/dt current transducer, i.e., a Rogowski coil or another current sensor such as a shunt or current transformer (CT). These inputs are fully differential voltage inputs with maximum differential input signal levels of $\pm 0.5\ \text{V}$, $\pm 0.25\ \text{V}$, and $\pm 0.125\ \text{V}$, depending on the full-scale selection—see the Analog Inputs section. Channel 1 also has a PGA with gain selections of 1, 2, 4, 8, or 16. The maximum signal level at these pins with respect to AGND is $\pm 0.5\ \text{V}$. Both inputs have internal ESD protection circuitry and can sustain an overvoltage of $\pm 6\ \text{V}$ without risk of permanent damage.
6, 7	V2N, V2P	Analog Inputs for Channel 2. This channel is intended for use with the voltage transducer. These inputs are fully differential voltage inputs with a maximum differential signal level of $\pm 0.5\ \text{V}$. Channel 2 also has a PGA with gain selections of 1, 2, 4, 8, or 16. The maximum signal level at these pins with respect to AGND is $\pm 0.5\ \text{V}$. Both inputs have internal ESD protection circuitry and can sustain an overvoltage of $\pm 6\ \text{V}$ without risk of permanent damage.
8	AGND	Analog Ground Reference. This pin provides the ground reference for the analog circuitry, i.e., ADCs and reference. This pin should be tied to the analog ground plane or to the quietest ground reference in the system. Use this quiet ground reference for all analog circuitry, such as antialiasing filters and current and voltage transducers. To minimize ground noise around the ADE7763, connect the quiet ground plane to the digital ground plane at only one point. It is acceptable to place the entire device on the analog ground plane.
9	REF _{IN/OUT}	Access to the On-Chip Voltage Reference. The on-chip reference has a nominal value of $2.4\ \text{V} \pm 8\%$ and a typical temperature coefficient of $30\ \text{ppm}/^\circ\text{C}$. An external reference source can also be connected at this pin. In either case, this pin should be decoupled to AGND with a $10\ \mu\text{F}$ capacitor in parallel with a $100\ \text{nF}$ ceramic capacitor.
10	DGND	Digital Ground Reference. This pin provides the ground reference for the digital circuitry, i.e., multiplier, filters, and digital-to-frequency converter. Because the digital return currents in the ADE7763 are small, it is acceptable to connect this pin to the analog ground plane of the system. However, high bus capacitance on the DOUT pin could result in noisy digital current, which could affect performance.
11	CF	Calibration Frequency Logic Output. The CF logic output gives active power information. This output is intended to be used for operational and calibration purposes. The full-scale output frequency can be adjusted by writing to the CFDEN and CFNUM registers—see the Energy-to-Frequency Conversion section.
12	ZX	Voltage Waveform (Channel 2) Zero-Crossing Output. This output toggles logic high and logic low at the zero crossing of the differential signal on Channel 2—see the Zero-Crossing Detection section.
13	SAG	This open-drain logic output goes active low when either no zero crossings are detected or a low voltage threshold (Channel 2) is crossed for a specified duration—see the Line Voltage Sag Detection section.

Pin No.	Mnemonic	Description
14	$\overline{\text{IRQ}}$	Interrupt Request Output. This is an active low, open-drain logic output. Maskable interrupts include active energy register rollover, active energy register at half level, and arrivals of new waveform samples—see the Interrupts section.
15	CLKIN	Master Clock for ADCs and Digital Signal Processing. An external clock can be provided at this logic input. Alternatively, a parallel resonant AT crystal can be connected across CLKIN and CLKOUT to provide a clock source for the ADE7763. The clock frequency for specified operation is 3.579545 MHz. Ceramic load capacitors between 22 pF and 33 pF should be used with the gate oscillator circuit. Refer to the crystal manufacturer's data sheet for load capacitance requirements.
16	CLKOUT	A crystal can be connected across this pin and CLKIN, as described for Pin 15, to provide a clock source for the ADE7763. The CLKOUT pin can drive one CMOS load when either an external clock is supplied at CLKIN or a crystal is being used.
17	$\overline{\text{CS}}$	Chip Select ¹ . Part of the 4-wire SPI serial interface. This active low logic input allows the ADE7763 to share the serial bus with several other devices—see the Serial Interface section.
18	SCLK	Serial Clock Input for the Synchronous Serial Interface ¹ . All serial data transfers are synchronized to this clock—see the Serial Interface section. The SCLK has a Schmitt-trigger input for use with a clock source that has a slow edge transition time, such as an opto-isolator output.
19	DOUT	Data Output for the Serial Interface. Data is shifted out at this pin upon the rising edge of SCLK. This logic output is normally in a high impedance state, unless it is driving data onto the serial data bus—see the Serial Interface section.
20	DIN	Data Input for the Serial Interface. Data is shifted in at this pin upon the falling edge of SCLK—see the Serial Interface section.

¹ It is recommended to drive the $\overline{\text{RESET}}$, SCLK, and $\overline{\text{CS}}$ pins with either a push-pull without an external series resistor or with an open-collector with a 10 k Ω pull-up. Pull-down resistors are not recommended because under some conditions, they may interact with internal circuitry.

TYPICAL PERFORMANCE CHARACTERISTICS

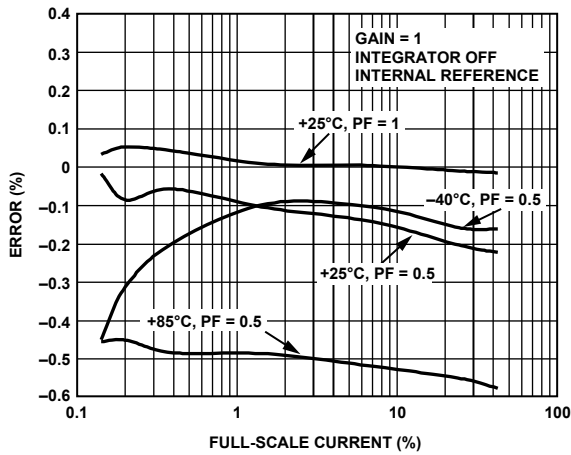

Figure 6. Active Energy Error as a Percentage of Reading (Gain = 1) over Power Factor with Internal Reference and Integrator Off

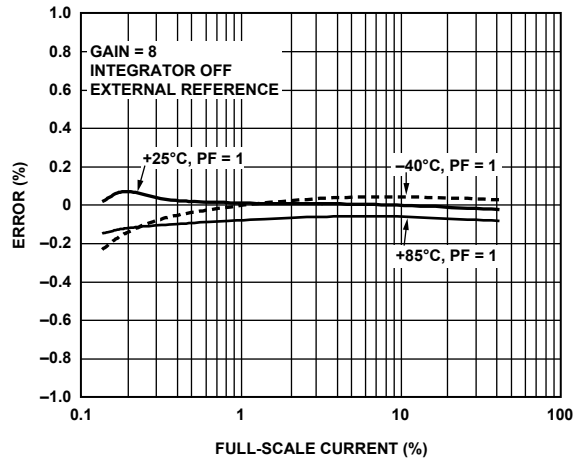

Figure 9. Active Energy Error as a Percentage of Reading (Gain = 8) over Temperature with External Reference and Integrator Off

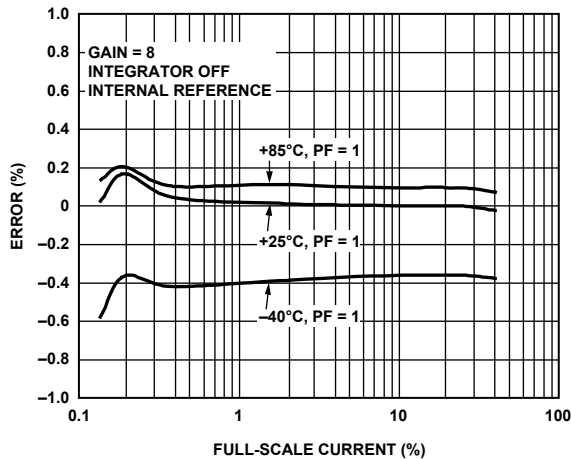

Figure 7. Active Energy Error as a Percentage of Reading (Gain = 8) over Temperature with Internal Reference and Integrator Off

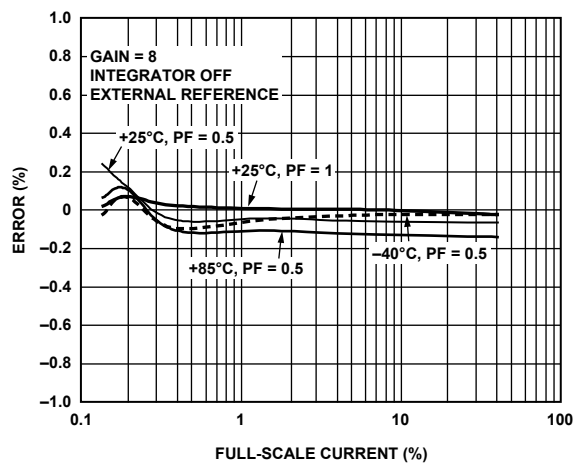

Figure 10. Active Energy Error as a Percentage of Reading (Gain = 8) over Power Factor with External Reference and Integrator Off

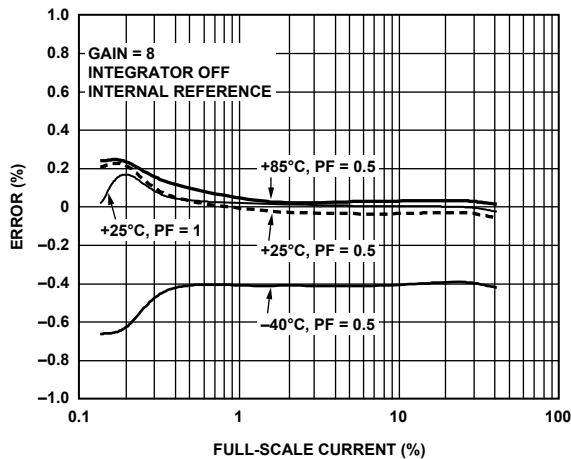

Figure 8. Active Energy Error as a Percentage of Reading (Gain = 8) over Power Factor with Internal Reference and Integrator Off

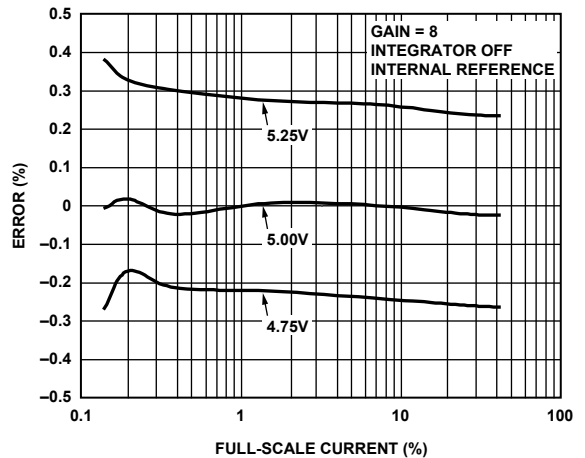

Figure 11. Active Energy Error as a Percentage of Reading (Gain = 8) over Power Supply with Internal Reference and Integrator Off

04481-A-006

04481-A-009

04481-A-007

04481-A-010

04481-A-008

04481-A-080

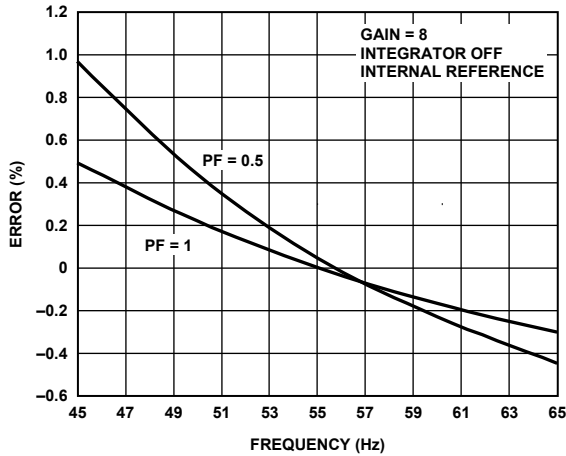

04481-A-012

Figure 12. Active Energy Error as a Percentage of Reading (Gain = 8) over Frequency with Internal Reference and Integrator Off

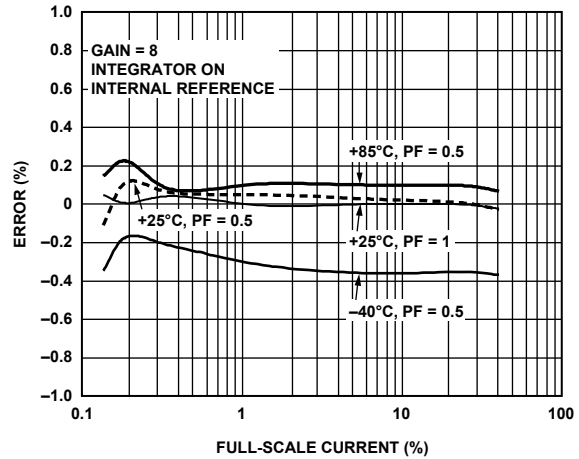

04481-A-016

Figure 15. Active Energy Error as a Percentage of Reading (Gain = 8) over Power Factor with Internal Reference and Integrator On

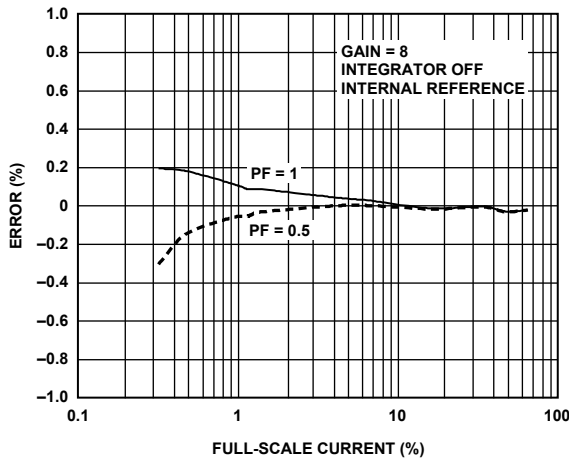

04481-A-013

Figure 13. IRMS Error as a Percentage of Reading (Gain = 8) with Internal Reference and Integrator Off

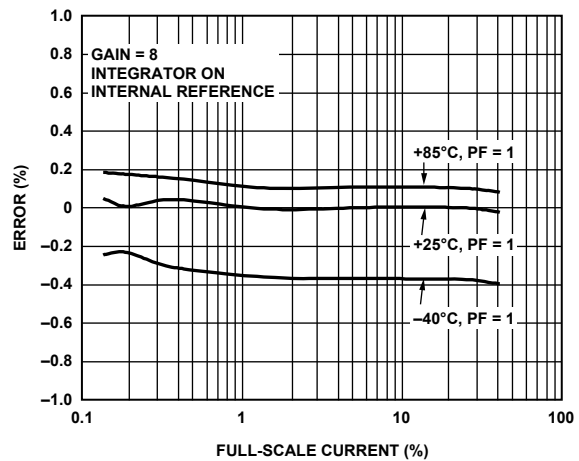

04481-A-015

Figure 16. Active Energy Error as a Percentage of Reading (Gain = 8) over Temperature with External Reference and Integrator On

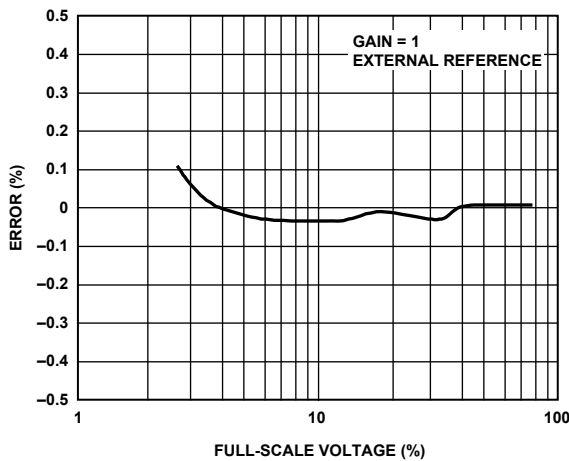

04481-A-020

Figure 14. VRMS Error as a Percentage of Reading (Gain = 1) with External Reference

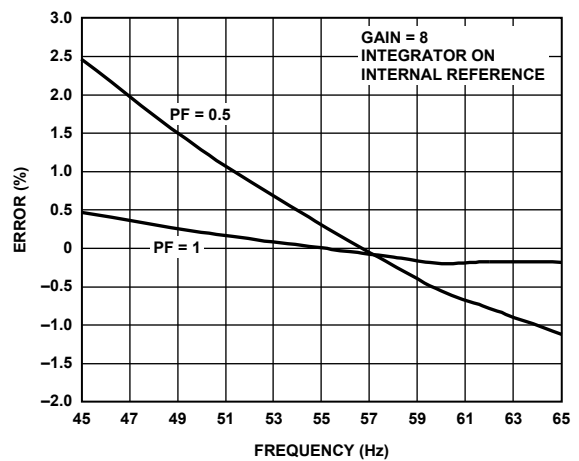

04481-A-017

Figure 17. Active Energy Error as a Percentage of Reading (Gain = 8) over Frequency with Internal Reference and Integrator On

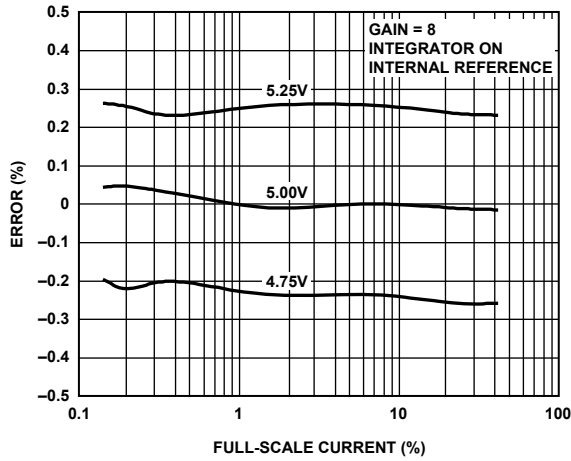

Figure 18. Active Energy Error as a Percentage of Reading (Gain = 8) over Power Supply with Internal Reference and Integrator On

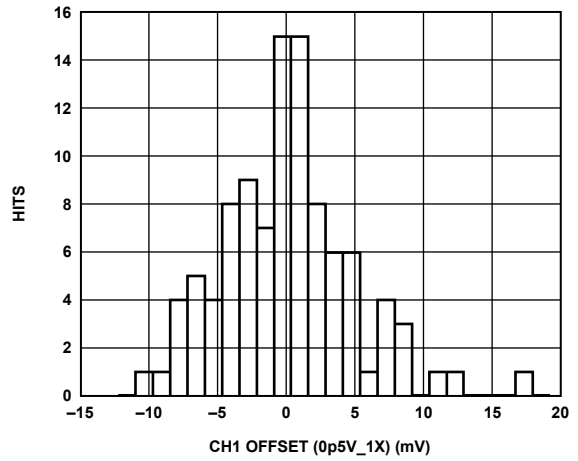

Figure 20. Channel 1 Offset (Gain = 1)

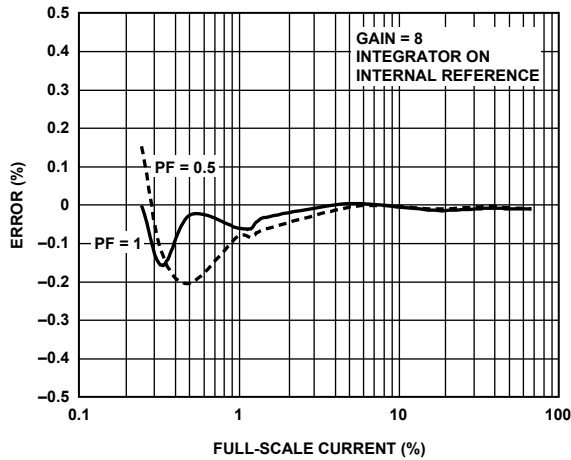

Figure 19. IRMS Error as a Percentage of Reading (Gain = 8) with Internal Reference and Integrator On

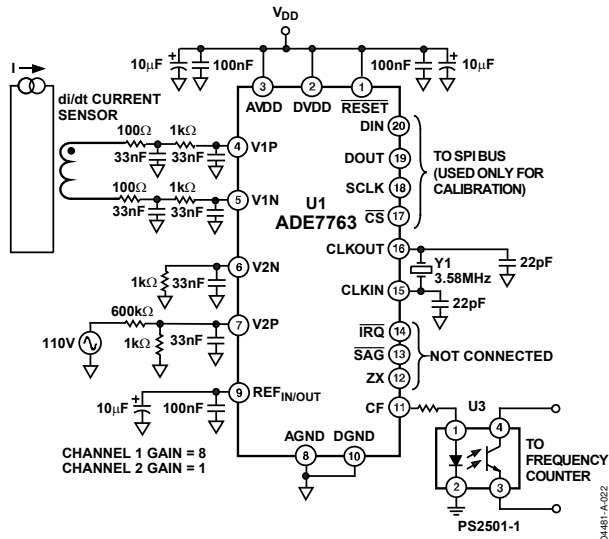

Figure 21. Test Circuit for Performance Curves with Integrator On

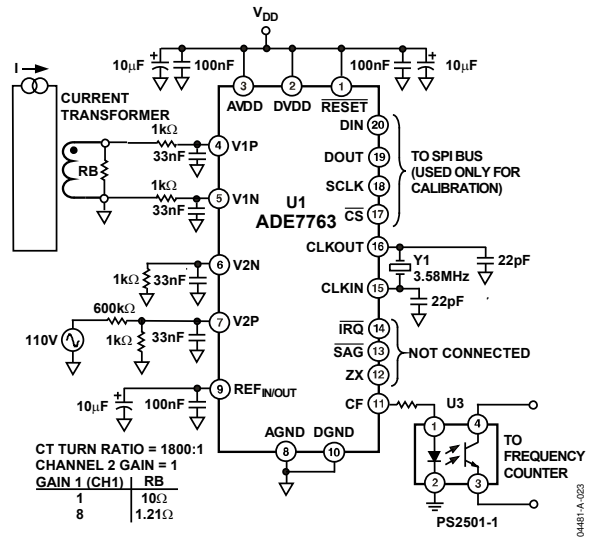

Figure 22. Test Circuit for Performance Curves with Integrator Off

THEORY OF OPERATION

ANALOG INPUTS

The ADE7763 has two fully differential voltage input channels. The maximum differential input voltage for input pairs V1P/V1N and V2P/V2N is ± 0.5 V. In addition, the maximum signal level on analog inputs for V1P/V1N and V2P/V2N is ± 0.5 V with respect to AGND.

Each analog input channel has a programmable gain amplifier (PGA) with possible gain selections of 1, 2, 4, 8, and 16. The gain selections are made by writing to the gain register—see Figure 24. Bits 0 to 2 select the gain for the PGA in Channel 1; the gain selection for the PGA in Channel 2 is made via Bits 5 to 7. Figure 23 shows how a gain selection for Channel 1 is made using the gain register.

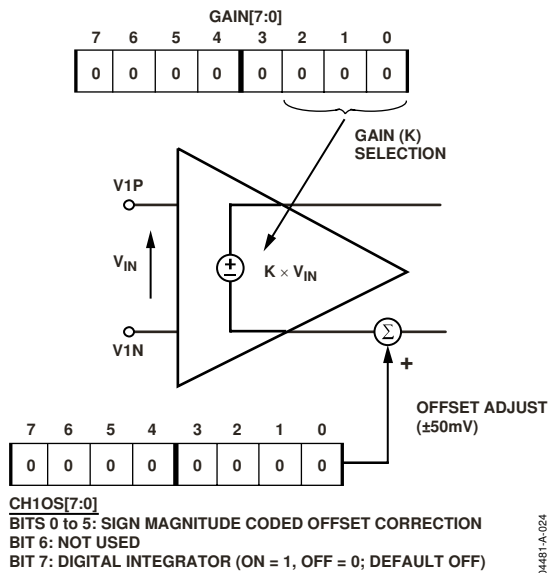

Figure 23. PGA in Channel 1

In addition to the PGA, Channel 1 also has a full-scale input range selection for the ADC. The ADC analog input range selection is also made using the gain register—see Figure 24. As previously mentioned, the maximum differential input voltage is 0.5 V. However, by using Bits 3 and 4 in the gain register, the maximum ADC input voltage can be set to 0.5 V, 0.25 V, or 0.125 V. This is achieved by adjusting the ADC reference—see the Reference Circuit section. Table 5 summarizes the maximum differential input signal level on Channel 1 for the various ADC range and gain selections.

Table 5. Maximum Input Signal Levels for Channel 1

Max Signal Channel 1	ADC Input Range Selection		
	0.5 V	0.25 V	0.125 V
0.5 V	Gain = 1	–	–
0.25 V	Gain = 2	Gain = 1	–
0.125 V	Gain = 4	Gain = 2	Gain = 1
0.0625 V	Gain = 8	Gain = 4	Gain = 2
0.0313 V	Gain = 16	Gain = 8	Gain = 4
0.0156 V	–	Gain = 16	Gain = 8
0.00781 V	–	–	Gain = 16

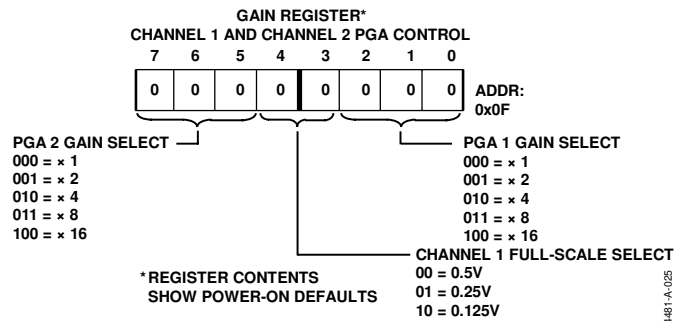

Figure 24. Analog Gain Register

It is also possible to adjust offset errors on Channel 1 and Channel 2 by writing to the offset correction registers (CH1OS and CH2OS, respectively). These registers allow channel offsets in the range ± 20 mV to ± 50 mV (depending on the gain setting) to be removed. Note that it is not necessary to perform an offset correction in an energy measurement application if HPF in Channel 1 is switched on. Figure 25 shows the effect of offsets on the real power calculation. As seen from Figure 25, an offset on Channel 1 and Channel 2 contributes a dc component after multiplication. Because this dc component is extracted by LPF2 to generate the active (real) power information, the offsets contribute an error to the active power calculation. This problem is easily avoided by enabling HPF in Channel 1. By removing the offset from at least one channel, no error component is generated at dc by the multiplication. Error terms at $\cos(\omega t)$ are removed by LPF2 and by integration of the active power signal in the active energy register (AENERGY[23:0])—see the Energy Calculation section.

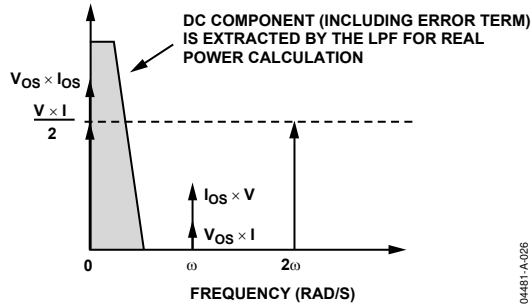

Figure 25. Effect of Channel Offsets on the Real Power Calculation

The contents of the offset correction registers are 6-bit, sign and magnitude coded. The weight of the LSB depends on the gain setting, i.e., 1, 2, 4, 8, or 16. Table 6 shows the correctable offset span for each of the gain settings and the LSB weight (mV) for the offset correction registers. The maximum value that can be written to the offset correction registers is $\pm 31d$ —see Figure 26. Figure 26 shows the relationship between the offset correction register contents and the offset (mV) on the analog inputs for a gain of 1. To perform an offset adjustment, connect the analog inputs to AGND; there should be no signal on either Channel 1 or Channel 2. A read from Channel 1 or Channel 2 using the waveform register indicates the offset in the channel. This offset can be canceled by writing an equal and opposite offset value to the Channel 1 offset register, or an equal value to the Channel 2 offset register. The offset correction can be confirmed by performing another read. Note that when adjusting the offset of Channel 1, the digital integrator and the HPF should be disabled.

Table 6. Offset Correction Range—Channels 1 and 2

Gain	Correctable Span	LSB Size
1	± 50 mV	1.61 mV/LSB
2	± 37 mV	1.19 mV/LSB
4	± 30 mV	0.97 mV/LSB
8	± 26 mV	0.84 mV/LSB
16	± 24 mV	0.77 mV/LSB

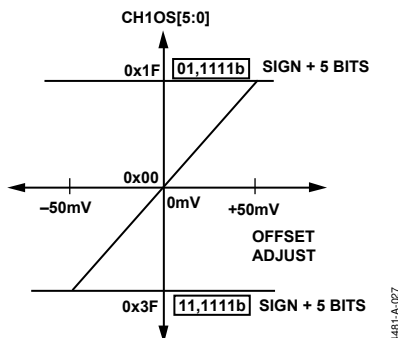

Figure 26. Channel 1 Offset Correction Range (Gain = 1)

The current and voltage rms offsets can be adjusted with the IRMSOS and VRMSOS registers—see the Channel 1 RMS Offset Compensation and Channel 2 RMS Offset Compensation sections.

di/dt CURRENT SENSOR AND DIGITAL INTEGRATOR

A di/dt sensor detects changes in magnetic field caused by ac current. Figure 27 shows the principle of a di/dt current sensor.

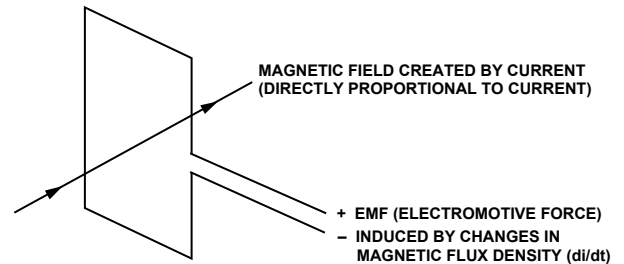

Figure 27. Principle of a di/dt Current Sensor

The flux density of a magnetic field induced by a current is directly proportional to the magnitude of the current. Changes in the magnetic flux density passing through a conductor loop generate an electromotive force (EMF) between the two ends of the loop. The EMF is a voltage signal that is proportional to the di/dt of the current. The voltage output from the di/dt current sensor is determined by the mutual inductance between the current-carrying conductor and the di/dt sensor. The current signal must be recovered from the di/dt signal before it can be used. An integrator is therefore necessary to restore the signal to its original form. The ADE7763 has a built-in digital integrator to recover the current signal from the di/dt sensor. The digital integrator on Channel 1 is switched off by default when the ADE7763 is powered up. Setting the MSB of CH1OS register turns on the integrator. Figure 28, Figure 29, Figure 30, and Figure 31 show the magnitude and phase response of the digital integrator.

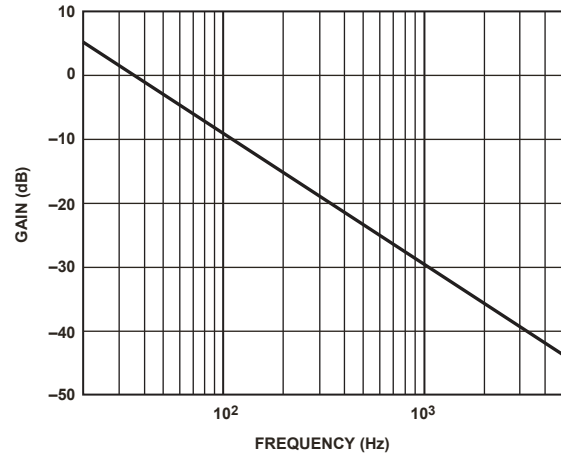

Figure 28. Combined Gain Response of the Digital Integrator and Phase Compensator

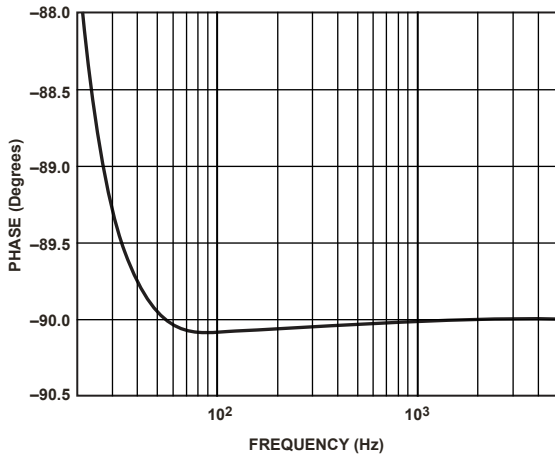

Figure 29. Combined Phase Response of the Digital Integrator and Phase Compensator

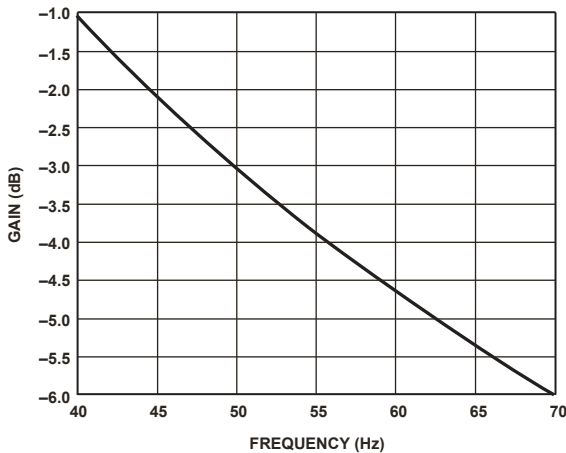

Figure 30. Combined Gain Response of the Digital Integrator and Phase Compensator (40 Hz to 70 Hz)

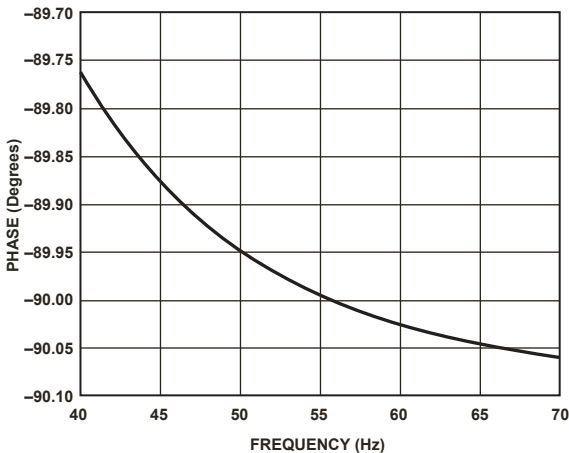

Figure 31. Combined Phase Response of the Digital Integrator and Phase Compensator (40 Hz to 70 Hz)

Note that the integrator has a -20 dB/dec attenuation and approximately a -90° phase shift. When combined with a di/dt sensor, the resulting magnitude and phase response should be a flat gain over the frequency band of interest. The di/dt sensor has a 20 dB/dec gain. It also generates significant high

frequency noise, necessitating a more effective antialiasing filter to avoid noise due to aliasing—see the Antialias Filter section.

When the digital integrator is switched off, the ADE7763 can be used directly with a conventional current sensor such as a current transformer (CT) or with a low resistance current shunt.

ZERO-CROSSING DETECTION

The ADE7763 has a zero-crossing detection circuit on Channel 2. This zero crossing is used to produce an external zero-crossing signal (ZX), which is used in the calibration mode (see the Calibrating an Energy Meter section). This signal is also used to initiate a temperature measurement (see the Temperature Measurement section).

Figure 32 shows how the zero-crossing signal is generated from the output of LPF1.

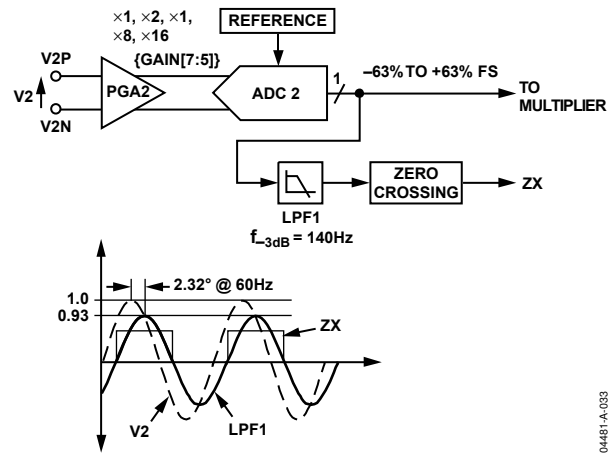

Figure 32. Zero-Crossing Detection on Channel 2

The ZX signal goes logic high upon a positive-going zero crossing and logic low upon a negative-going zero crossing on Channel 2. The ZX signal is generated from the output of LPF1. LPF1 has a single pole at 140 Hz (@ CLKIN = 3.579545 MHz). As a result, there is a phase lag between the analog input signal V2 and the output of LPF1. The phase response of this filter is shown in the Channel 2 Sampling section. The phase lag response of LPF1 results in a time delay of approximately 1.14 ms (@ 60 Hz) between the zero crossing on the analog inputs of Channel 2 and the rising or falling edge of ZX.

Zero-crossing detection also drives the ZX flag in the interrupt status register. The ZX flag is set to Logic 1 on the rising and falling edge of the voltage waveform. It remains high until the status register is read with reset. An active low in the $\overline{\text{IRQ}}$ output appears if the corresponding bit in the interrupt enable register is set to Logic 1.

The flag in the interrupt status register and the $\overline{\text{IRQ}}$ output are set to their default values when reset (RSTSTATUS) is read in the interrupt status register.

Zero-Crossing Timeout

Zero-crossing detection has an associated timeout register, ZXTOUT. This unsigned, 12-bit register is decremented (1 LSB)

04481-A-030

04481-A-031

04481-A-032

04481-A-033

every 128/CLKIN seconds. The register is reset to its user-programmed, full-scale value when a zero crossing on Channel 2 is detected. The default power-on value in this register is 0xFFFF. If the internal register decrements to 0 before a zero crossing is detected and the DISSAG bit in the mode register is Logic 0, the SAG pin goes active low. The absence of a zero crossing is also indicated on the $\overline{\text{IRQ}}$ pin if the ZXTO enable bit in the interrupt enable register is set to Logic 1. Irrespective of the enable bit setting, the ZXTO flag in the interrupt status register is always set when the internal ZXTOOUT register is decremented to 0—see the Interrupts section.

The ZXOUT register, Address 0x1D, can be written to and read from by the user—see the Serial Interface section. The resolution of the register is 128/CLKIN seconds per LSB; therefore, the maximum delay for an interrupt is 0.15 seconds ($128/\text{CLKIN} \times 2^{12}$).

Figure 33 shows the zero-crossing timeout detection when the line voltage stays at a fixed dc level for more than $\text{CLKIN}/128 \times \text{ZXTOOUT}$ seconds.

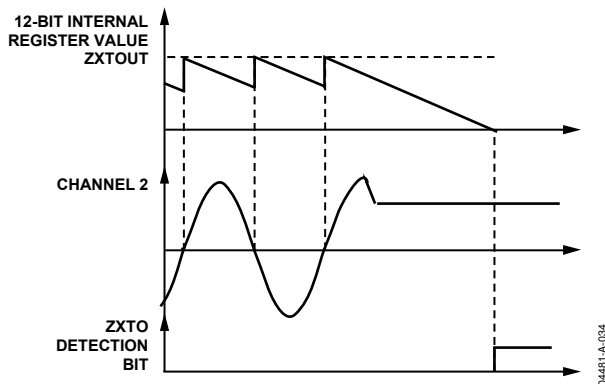

Figure 33. Zero-Crossing Timeout Detection

0481-A-034

PERIOD MEASUREMENT

The ADE7763 provides the period measurement of the line. The PERIOD register is an unsigned, 16-bit register that is updated every period and always has an MSB of zero.

The formula for the period register is shown below:

$$PERIOD = \frac{CLKIN \times 16}{4 \times 32 \times f}$$

Where CLKIN is the crystal frequency (3.579545 MHz recommended), and f is the line frequency.

When CLKIN = 3.579545 MHz, the resolution of this register is 2.2 $\mu\text{s}/\text{LSB}$, which represents 0.013% when the line frequency is 60 Hz. When the line frequency is 60 Hz, the value of the period register is approximately 7457d. The length of the register enables the measurement of line frequencies as low as 13.9 Hz.

The period register is stable at ± 1 LSB when the line is established and the measurement does not change. This filter is associated with a settling time of 1.8 seconds before the measurement is stable. See the Calibrating an Energy Meter section for more on the period register.

POWER SUPPLY MONITOR

The ADE7763 contains an on-chip power supply monitor. The analog supply (AVDD) is continuously monitored. If the supply is less than $4 \text{ V} \pm 5\%$, the ADE7763 will go into an inactive state and no energy will accumulate. This is useful to ensure correct device operation during power-up and power-down stages. In addition, built-in hysteresis and filtering help prevent false triggering due to noisy supplies.

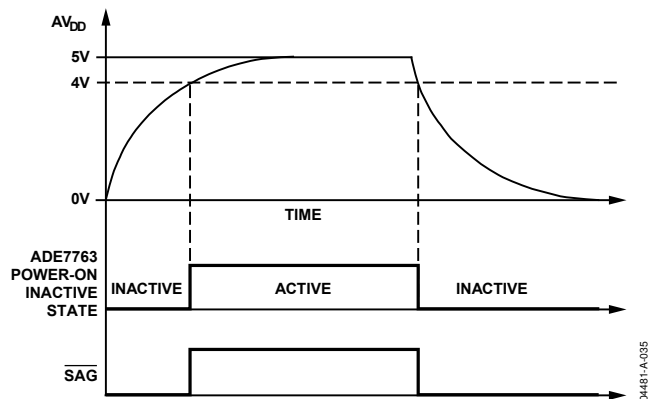

Figure 34. On-Chip Power Supply Monitor

0481-A-035

As seen in Figure 34, the trigger level is nominally set at 4 V. The tolerance on this trigger level is about $\pm 5\%$. The SAG pin can also be used as a power supply monitor input to the MCU. The SAG pin goes logic low when the ADE7763 is in its inactive state. The power supply and decoupling for the part should be such that the ripple at AVDD does not exceed $5 \text{ V} \pm 5\%$, as specified for normal operation.

LINE VOLTAGE SAG DETECTION

In addition to detecting the loss of the line voltage when there are no zero crossings on the voltage channel, the ADE7763 can also be programmed to detect when the absolute value of the line voltage drops below a peak value for a specified number of line cycles. This condition is illustrated in Figure 35.

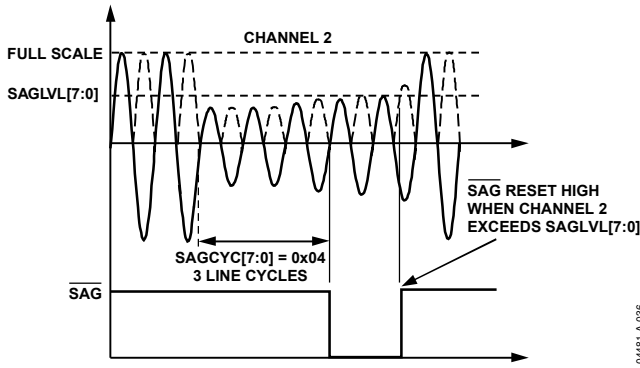

Figure 35. Sag Detection

In Figure 35 the line voltage falls below a threshold that has been set in the sag level register (SAGLVL[7:0]) for three line cycles. The quantities 0 and 1 are not valid for the SAGCYC register, and the contents represent one more than the desired number of full line cycles. For example, if the DISSAG bit in the mode register is Logic 0 and the sag cycle register (SAGCYC[7:0]) contains 0x04, the SAG pin goes active low at the end of the third line cycle for which the line voltage (Channel 2 signal) falls below the threshold. As is the case when zero crossings are no longer detected, the sag event is also recorded by setting the SAG flag in the interrupt status register. If the SAG enable bit is set to Logic 1, the $\overline{\text{IRQ}}$ logic output will go active low—see the Interrupts section. The SAG pin goes logic high again when the absolute value of the signal on Channel 2 exceeds the level set in the sag level register. This is shown in Figure 35 when the SAG pin goes high again during the fifth line cycle from the time when the signal on Channel 2 first dropped below the threshold level.

Sag Level Set

The contents of the sag level register (1 byte) are compared to the absolute value of the most significant byte output from LPF1 after it is shifted left by one bit. For example, the nominal maximum code from LPF1 with a full-scale signal on Channel 2 is 0x2518—see the Channel 2 Sampling section. Shifting one bit left gives 0x4A30. Therefore, writing 0x4A to the SAG level register puts the sag detection level at full scale. Writing 0x00 or 0x01 puts the sag detection level at 0. The SAG level register is compared to the most significant byte of a waveform sample after the shift left, and detection occurs when the contents of the sag level register are greater.

PEAK DETECTION

The ADE7763 can also be programmed to detect when the absolute value of the voltage or current channel exceeds a specified peak value. Figure 36 illustrates the behavior of the peak detection for the voltage channel.

Both Channel 1 and Channel 2 are monitored at the same time.

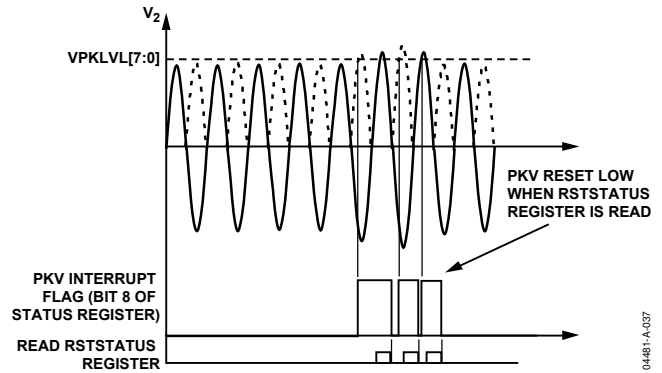

Figure 36. Peak Level Detection

Figure 36 shows a line voltage exceeding a threshold that has been set in the voltage peak register (VPKLV[7:0]). The voltage peak event is recorded by setting the PKV flag in the interrupt status register. If the PKV enable bit is set to Logic 1 in the interrupt mask register, the $\overline{\text{IRQ}}$ logic output will go active low. Similarly, the current peak event is recorded by setting the PKI flag in the interrupt status register—see the Interrupts section.

Peak Level Set

The contents of the VPKLV and IPKLV registers are compared to the absolute value of Channel 1 and Channel 2, respectively, after they are multiplied by 2. For example, the nominal maximum code from the Channel 1 ADC with a full-scale signal is 0x2851EC—see the Channel 1 Sampling section. Multiplying by 2 gives 0x50A3D8. Therefore, writing 0x50 to the IPKLV register, for example, puts the Channel 1 peak detection level at full scale and sets the current peak detection to its least sensitive value. Writing 0x00 puts the Channel 1 detection level at 0. Peak level detection is done by comparing the contents of the IPKLV register to the incoming Channel 1 sample. The $\overline{\text{IRQ}}$ pin indicates that the peak level is exceeded if the PKI or PKV bits are set in the interrupt enable register (IRQEN [15:0]) at Address 0x0A.

Peak Level Record

The ADE7763 records the maximum absolute value reached by Channel 1 and Channel 2 in two different registers—IPEAK and VPEAK, respectively. VPEAK and IPEAK are 24-bit, unsigned registers. These registers are updated at a rate of CLKIN/4 regardless of the waveform sampling rate. The contents of the VPEAK register correspond to two times the maximum absolute value observed on the Channel 2 input. The contents of IPEAK represent the maximum absolute value observed on the Channel 1

input. Reading the RSTVPEAK and RSTIPEAK registers clears their respective contents after the read operation.

INTERRUPTS

Interrupts are managed through the interrupt status register (STATUS[15:0]) and the interrupt enable register (IRQEN[15:0]). When an interrupt event occurs, the corresponding flag in the status register is set to Logic 1—see the Interrupt Status Register section. If the enable bit for this interrupt in the interrupt enable register is Logic 1, the $\overline{\text{IRQ}}$ logic output will go active low. The flag bits in the status register are set irrespective of the state of the enable bits.

To determine the source of the interrupt, the system master (MCU) should perform a read from the status register with reset (RSTSTATUS[15:0]). This is achieved by carrying out a read from Address 0Ch. The $\overline{\text{IRQ}}$ output goes logic high after the completion of the interrupt status register read command—see the Interrupt Timing section. When carrying out a read with reset, the ADE7763 is designed to ensure that no interrupt events are missed. If an interrupt event occurs as the status register is being read, the event will not be lost and the $\overline{\text{IRQ}}$ logic output will be guaranteed to go high for the duration of the interrupt status register data transfer before going logic low again to indicate the pending interrupt. See the next section for a more detailed description.

Using Interrupts with an MCU

Figure 38 shows a timing diagram with a suggested implementation of ADE7763 interrupt management using an MCU. At time t_1 , the $\overline{\text{IRQ}}$ line goes active low, indicating that one or more interrupt events have occurred. Tie the $\overline{\text{IRQ}}$ logic output to a negative edge-triggered external interrupt on the MCU. Configure the MCU to start executing its interrupt service routine (ISR) when a negative edge is detected on the $\overline{\text{IRQ}}$ line. After entering the ISR, disable all interrupts by using the global interrupt enable bit. At this point, the MCU $\overline{\text{IRQ}}$ external interrupt flag can be cleared to capture interrupt events that occur during the current ISR. When the MCU interrupt flag is cleared, a read from the status register with reset is carried out. This causes the $\overline{\text{IRQ}}$ line to reset to logic high (t_2)—see the Interrupt Timing section. The status register contents are used to determine the source of the interrupt(s) and, therefore, the appropriate action to be taken. If a subsequent interrupt event occurs during the ISR, that event will be recorded by the MCU external interrupt flag being set again (t_3). Upon the completion of the ISR, the global interrupt mask is cleared (same instruction cycle) and the external interrupt flag causes the MCU to jump to its ISR again. This ensures that the MCU does not miss any external interrupts.

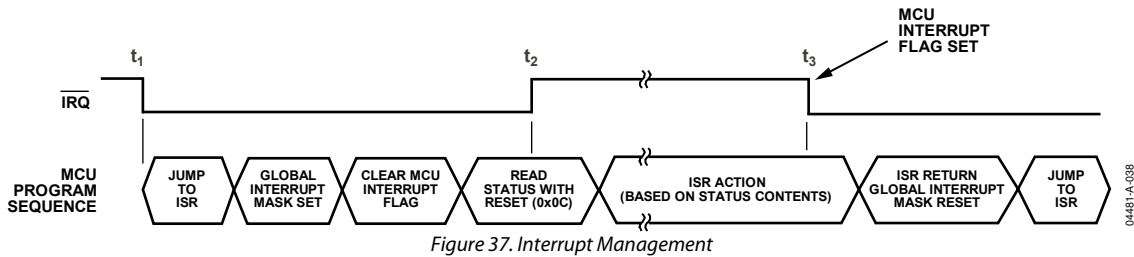

Figure 37. Interrupt Management

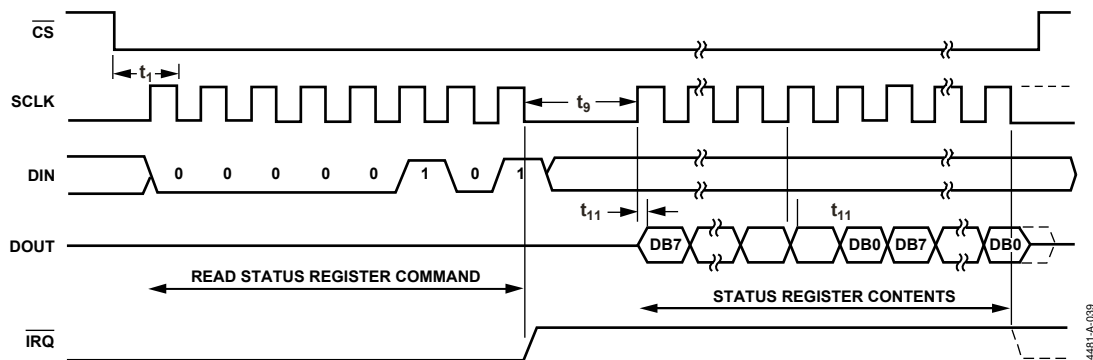

Figure 38. Interrupt Timing

Interrupt Timing

Review the Serial Interface section before reading this section. As previously described, when the $\overline{\text{IRQ}}$ output goes low, the MCU ISR will read the interrupt status register to determine the source of the interrupt. When reading the status register contents, the $\overline{\text{IRQ}}$ output is set high upon the last falling edge of SCLK of the first byte transfer (read interrupt status register command). The $\overline{\text{IRQ}}$ output is held high until the last bit of the next 15-bit transfer is shifted out (interrupt status register contents)—see Figure 37. If an interrupt is pending at this time, the $\overline{\text{IRQ}}$ output will go low again. If no interrupt is pending, the $\overline{\text{IRQ}}$ output will stay high.

TEMPERATURE MEASUREMENT

There is an on-chip temperature sensor. A temperature measurement can be made by setting Bit 5 in the mode register. When Bit 5 is set logic high in the mode register, the ADE7763 initiates a temperature measurement of the next zero crossing. When the zero crossing on Channel 2 is detected, the voltage output from the temperature sensing circuit is connected to ADC1 (Channel 1) for digitizing. The resulting code is processed and placed in the temperature register (TEMP[7:0]) approximately 26 μs later (24 CLKIN/4 cycles). If enabled in the interrupt enable register (Bit 5), the $\overline{\text{IRQ}}$ output will go active low when the temperature conversion is finished.

The contents of the temperature register are signed (two's complement) with a resolution of approximately 1.5 LSB/°C. The temperature register produces a code of 0x00 when the ambient temperature is approximately -25°C. The temperature measurement is uncalibrated in the ADE7763 and might have an offset tolerance as high as $\pm 25^\circ\text{C}$.

ANALOG-TO-DIGITAL CONVERSION

The analog-to-digital conversion is carried out using two second-order Σ - Δ ADCs. For simplicity, the block diagram in Figure 39 shows a first-order Σ - Δ ADC. The converter comprises two parts: the Σ - Δ modulator and the digital low-pass filter.

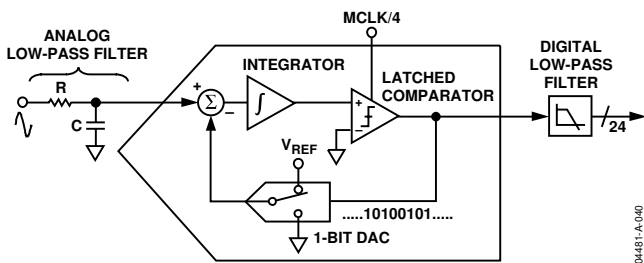

Figure 39. First-Order Σ - Δ ADC

A Σ - Δ modulator converts the input signal into a continuous serial stream of 1s and 0s at a rate determined by the sampling clock. In the ADE7763, the sampling clock is equal to CLKIN/4. The 1-bit DAC in the feedback loop is driven by the serial data stream. The DAC output is subtracted from the input signal. If the loop gain is high enough, the average value of the DAC

output (and therefore the bit stream) will approach that of the input signal level. For any given input value in a single sampling interval, the data from the 1-bit ADC is virtually meaningless. Only when a large number of samples are averaged can a meaningful result be obtained. This averaging is carried out in the second part of the ADC, the digital low-pass filter. By averaging a large number of bits from the modulator, the low-pass filter can produce 24-bit data-words that are proportional to the input signal level.

The Σ - Δ converter uses two techniques to achieve high resolution from what is essentially a 1-bit conversion technique. The first is oversampling. Oversampling means that the signal is sampled at a rate (frequency) that is many times higher than the bandwidth of interest. For example, the sampling rate in the ADE7763 is CLKIN/4 (894 kHz) and the band of interest is 40 Hz to 2 kHz. Oversampling has the effect of spreading the quantization noise (noise due to sampling) over a wider bandwidth. With the noise spread more thinly over a wider bandwidth, the quantization noise in the band of interest decreases—see Figure 40. However, oversampling alone is not efficient enough to improve the signal-to-noise ratio (SNR) in the band of interest. For example, an oversampling ratio of 4 is required just to increase the SNR by 6 dB (1 bit). To keep the oversampling ratio at a reasonable level, it is possible to shape the quantization noise so that the majority of the noise lies at higher frequencies. In the Σ - Δ modulator, the noise is shaped by the integrator, which has a high-pass-type response for the quantization noise. The result is that most of the noise is at higher frequencies, where it can be removed by the digital low-pass filter. This noise shaping is shown in Figure 40.

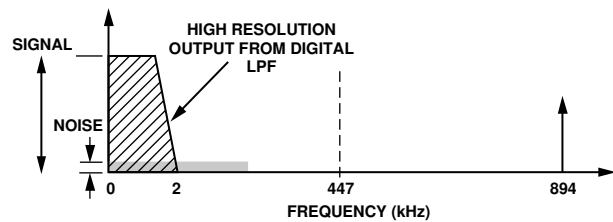
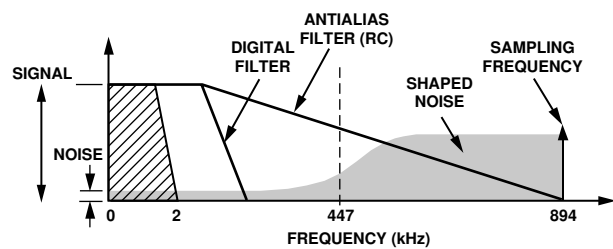

Figure 40. Noise Reduction due to Oversampling and Noise Shaping in the Analog Modulator

Antialias Filter

Figure 39 also shows an analog low-pass filter (RC) on the input to the modulator. This filter prevents aliasing, which is an artifact of all sampled systems. Aliasing means that frequency components in the input signal to the ADC that are higher than half the sampling rate of the ADC appear in the sampled signal at a frequency below half the sampling rate. Figure 41 illustrates the effect. Frequency components (shown as arrows) above half the sampling frequency (also known as the Nyquist frequency, i.e., 447 kHz) are imaged or folded back down below 447 kHz. This happens with all ADCs, regardless of the architecture. In the example shown, only frequencies near the sampling frequency, i.e., 894 kHz, move into the band of interest for metering, i.e., 40 Hz to 2 kHz. This allows the use of a very simple LPF (low-pass filter) to attenuate high frequency (near 900 kHz) noise, and it prevents distortion in the band of interest. For conventional current sensors, a simple RC filter (single-pole LPF) with a corner frequency of 10 kHz produces an attenuation of approximately 40 dB at 894 kHz—see Figure 41. The 20 dB per decade attenuation is usually sufficient to eliminate the effects of aliasing for conventional current sensors; however, for a di/dt sensor such as a Rogowski coil, the sensor has a 20 dB per decade gain. This neutralizes the -20 dB per decade attenuation produced by one simple LPF. Therefore, when using a di/dt sensor, care should be taken to offset the 20 dB per decade gain. One simple approach is to cascade two RC filters to produce the -40 dB per decade attenuation.

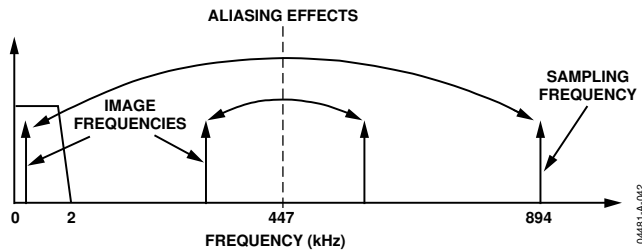

Figure 41. ADC and Signal Processing in Channel 1 Outline Dimensions

ADC Transfer Function

The following expression relates the output of the LPF in the Σ-Δ ADC to the analog input signal level. Both ADCs in the ADE7763 are designed to produce the same output code for the same input signal level.

$$Code (ADC) = 3.0492 \times \frac{V_{IN}}{V_{OUT}} \times 262,144 \quad (1)$$

Therefore, with a full-scale signal on the input of 0.5 V and an internal reference of 2.42 V, the ADC output code is nominally 165,151, or 0x2851F. The maximum code from the ADC is ±262,144; this is equivalent to an input signal level of ±0.794 V. However, for specified performance, do not exceed the 0.5 V full-scale input signal level.

Reference Circuit

Figure 42 shows a simplified version of the reference output circuitry. The nominal reference voltage at the REF_{IN/OUT} pin is 2.42 V. This is the reference voltage used for the ADCs. However, Channel 1 has three input range options that are selected by dividing down the reference value used for the ADC in Channel 1. The reference value used for Channel 1 is divided down to ½ and ¼ of the nominal value by using an internal resistor divider, as shown in Figure 42.

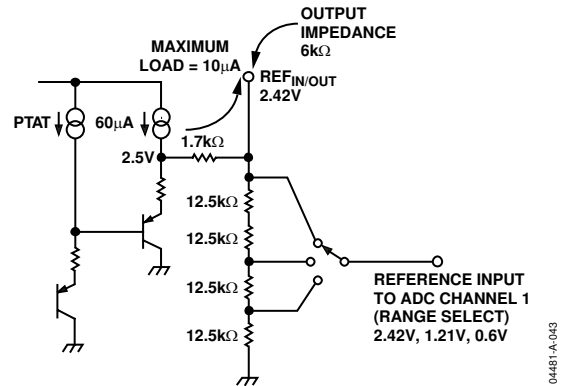

Figure 42. Reference Circuit Output

The REF_{IN/OUT} pin can be overdriven by an external source such as a 2.5 V reference. Note that the nominal reference value supplied to the ADCs is now 2.5 V, not 2.42 V, which increases the nominal analog input signal range by 2.5/2.42 × 100% = 3% or from 0.5 V to 0.5165 V.

The voltage of the ADE7763 reference drifts slightly with changes in temperature—see Table 1 for the temperature coefficient specification (in ppm/°C). The value of the temperature drift varies from part to part. Because the reference is used for the ADCs in both Channels 1 and 2, any x% drift in the reference results in 2x% deviation in the meter accuracy. The reference drift that results from a temperature change is usually very small, typically much smaller than the drift of other components on a meter. However, if guaranteed temperature performance is needed, use an external voltage reference. Alternatively, the meter can be calibrated at multiple temperatures. Real-time compensation can be achieved easily by using the on-chip temperature sensor.

CHANNEL 1 ADC

Figure 43 shows the ADC and signal processing chain for Channel 1. In waveform sampling mode, the ADC outputs a signed, twos complement, 24-bit data-word at a maximum of 27.9 kSPS (CLKIN/128). With the specified full-scale analog input signal of 0.5 V (or 0.25 V or 0.125 V—see the Analog Inputs section), the ADC produces an output code that is approximately between 0x28 51EC (+2,642,412d) and 0xD7 AE14 (-2,642,412d)—see Figure 43.

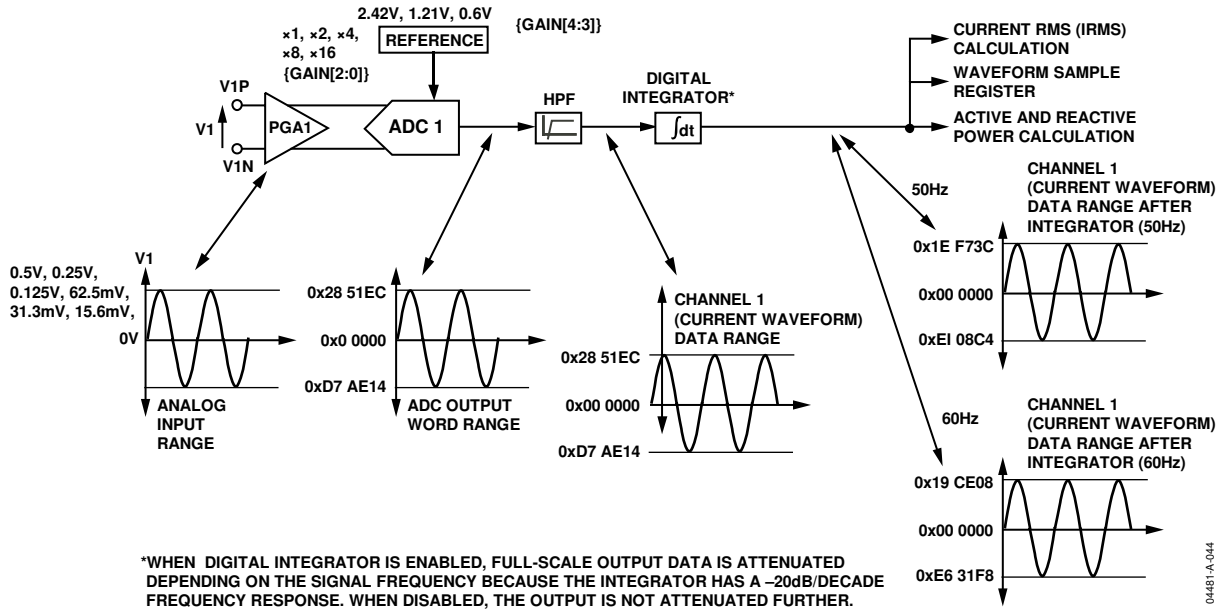

Figure 43. ADC and Signal Processing in Channel 1

Channel 1 Sampling

The waveform samples may be routed to the waveform register (MODE[14:13] = 1, 0) for the system master (MCU) to read. To enable waveform sampling mode, set the WSMP bit (Bit 3) in the interrupt enable register to Logic 1. The active and apparent power as well as the energy calculation remain uninterrupted during waveform sampling.

In waveform sampling mode, choose one of four output sample rates using Bits 11 and 12 of the mode register (WAVSEL 1, 0). The output sample rate can be 27.9 kSPS, 14 kSPS, 7 kSPS, or 3.5 kSPS—see the Mode Register (0X09) section. The interrupt request output, \overline{IRQ} , signals a new sample availability by going active low. The timing is shown in Figure 44. The 24-bit waveform samples are transferred from the ADE7763 one byte (eight bits) at a time, with the most significant byte shifted out first. The 24-bit data-word is right justified—see the Serial Interface section. The Channel 1 waveform samples have a settling time of approximately 150 μ s. The interrupt request output \overline{IRQ} stays low until the interrupt routine reads the reset status register—see the Interrupts section.

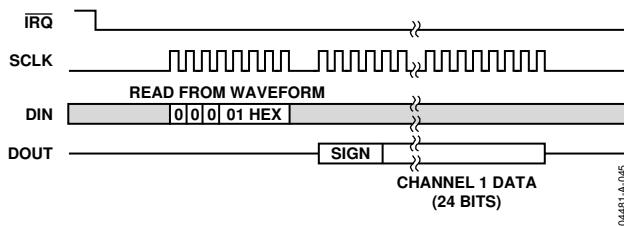

Figure 44. Waveform Sampling Channel 1

Channel 1 RMS Calculation

The root mean square (rms) value of a continuous signal $I(t)$ is defined as

$$IRMS = \sqrt{\frac{1}{T} \times \int_0^T I^2(t) dt} \tag{2}$$

For time sampling signals, the rms calculation involves squaring the signal, taking the average, and obtaining the square root:

$$IRMS = \sqrt{\frac{1}{N} \times \sum_{i=1}^N I^2(i)} \tag{3}$$

Figure 45 shows the detail of the signal processing chain for the rms calculation on Channel 1. The Channel 1 rms value is processed from the samples used in the Channel 1 waveform sampling mode. The Channel 1 rms value is stored in an unsigned, 24-bit register (IRMS). One LSB of the Channel 1 rms register is equivalent to 1 LSB of a Channel 1 waveform sample. The update rate of the Channel 1 rms measurement is $CLKIN/4$. The channel 1 rms measurement has a settling time of approximately 876 ms with the integrator off and 1340 ms with the integrator on.

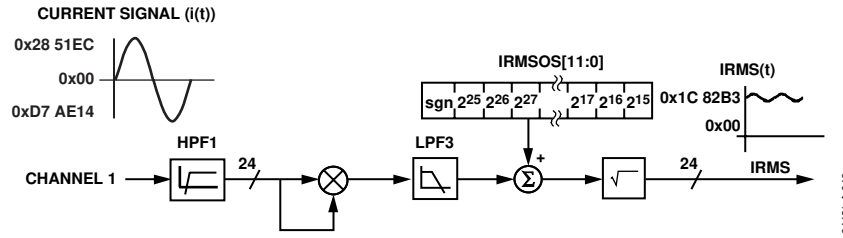

Figure 45. Channel 1 RMS Signal Processing

With the specified full-scale analog input signal of 0.5 V, the ADC produces an output code that is approximately $\pm 2,642,412d$ —see the Channel 1 ADC section. The equivalent rms value of a full-scale ac signal is $1,868,467d$ ($0x1C82B3$). The current rms measurement provided in the ADE7763 is accurate to within 0.5% for signal input between full scale and full scale/100. Converting the register value to its equivalent in amps must be done externally in the microprocessor using an amps/LSB constant. To minimize noise, synchronize the reading of the rms register with the zero crossing of the voltage input and take the average of a number of readings.

Channel 1 RMS Offset Compensation

The ADE7763 incorporates a Channel 1 rms offset compensation register (IRMSOS). This is a 12-bit, signed register that can be used to remove offset in the Channel 1 rms calculation. An offset might exist in the rms calculation due to input noises that are integrated in the dc component of $V^2(t)$. The offset calibration eliminates the influence of input noises from the rms measurement.

One LSB of the Channel 1 rms offset is equivalent to 32,768 LSB of the square of the Channel 1 rms register. Assuming that the maximum value from the Channel 1 rms calculation is $1,868,467d$ with full-scale ac inputs, then 1 LSB of the Channel 1 rms offset represents 0.46% of the measurement error at -60 dB down of full scale.

$$IRMS = \sqrt{IRMS_0^2 + IRMSOS \times 32768} \tag{4}$$

where $IRMS_0$ is the rms measurement without offset correction.

To measure the offset of the rms measurement, two data points are needed from nonzero input values, for example, the base current, I_b , and $I_{max}/100$. The offset can be calculated from these measurements. Note that for correct operation, only positive values should be written to the IRMSOS register.

CHANNEL 2 ADC

Channel 2 Sampling

To enable waveform sampling mode, set the WSMP bit (Bit 3) in the interrupt enable register to Logic 1. In Channel 2 waveform sampling mode ($MODE[14:13] = 1, 1$ and $WSMP = 1$),

the ADC output code scaling for Channel 2 is not the same as it is for Channel 1. The Channel 2 waveform sample is a 16-bit word and sign extended to 24 bits. The Channel 2 waveform samples have a settling time of approximately 1.23 ms. For normal operation, the differential voltage signal between $V2P$ and $V2N$ should not exceed 0.5 V. With maximum voltage input (± 0.5 V at PGA gain of 1), the output from the ADC swings between $0x2852$ and $0xD7AE$ ($\pm 10,322d$). However, before being passed to the waveform register, the ADC output is passed through a single-pole, low-pass filter with a cutoff frequency of 140 Hz. The plots in Figure 46 show the magnitude and phase response of this filter.

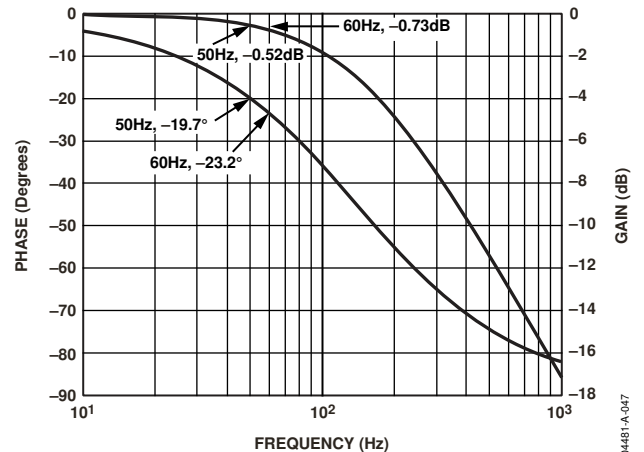

Figure 46. Magnitude and Phase Response of LPF1

The LPF1 has the effect of attenuating the signal. For example, if the line frequency is 60 Hz, the signal at the output of LPF1 will be attenuated by about 8%.

$$|H(f)| = \frac{1}{\sqrt{1 + \left(\frac{60 \text{ Hz}}{140 \text{ Hz}}\right)^2}} = 0.919 = -0.73 \text{ db} \tag{5}$$

Note LPF1 does not affect the active power calculation. The signal processing chain in Channel 2 is illustrated in Figure 47.

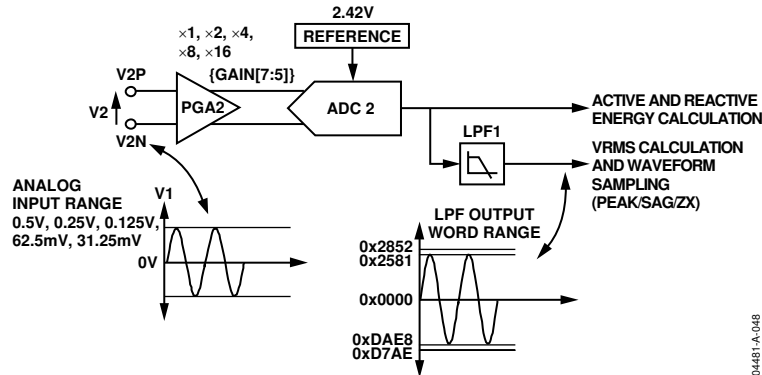

Figure 47. ADC and Signal Processing in Channel 2

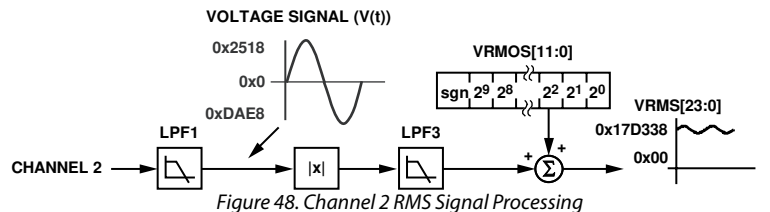

Figure 48. Channel 2 RMS Signal Processing

Channel 2 has only one analog input range (0.5 V differential). Like Channel 1, Channel 2 has a PGA with gain selections of 1, 2, 4, 8, and 16. For energy measurement, the output of the ADC is passed directly to the multiplier and is not filtered. An HPF is not required to remove any dc offset; it is only required that the offset is removed from one channel to eliminate errors caused by offsets in the power calculation. In waveform sampling mode, one of four output sample rates can be chosen by using Bits 11 and 12 of the mode register. The available output sample rates are 27.9 kSPS, 14 kSPS, 7 kSPS, or 3.5 kSPS—see the Mode Register (0X09) section. The interrupt request output IRQ indicates that a sample is available by going active low. The timing is the same as that for Channel 1, as shown in Figure 44.

Channel 2 RMS Calculation

Figure 48 shows the details of the signal processing chain for the rms estimation on Channel 2. This Channel 2 rms estimation is done in the ADE7763 using the mean absolute value calculation, as shown in Figure 48. The Channel 2 rms value is processed from the samples used in the Channel 2 waveform sampling mode. The rms value is slightly attenuated due to LPF1. The Channel 2 rms value is stored in the unsigned, 24-bit VRMS register. The update rate of the Channel 2 rms measurement is CLKIN/4. The Channel 2 rms measurement has a settling time of approximately 670 ms.

With the specified full-scale ac analog input signal of 0.5 V, the output from LPF1 swings between 0x2518 and 0xDAE8 at 60 Hz—see the Channel 2 ADC section. The equivalent rms value of this full-scale ac signal is approximately 1,561,400 (0x17 D338) in the VRMS register. The voltage rms measurement provided in the ADE7763 is accurate to within ±0.5% for

signal input between full scale and full scale/20. The conversion from the register value to volts must be done externally in the microprocessor using a volts/LSB constant. Because the low-pass filter used for calculating the rms value is imperfect, there is some ripple noise from 2ω term present in the rms measurement. To minimize the effect of noise in the reading, synchronize the rms reading with the zero crossings of the voltage input.

Channel 2 RMS Offset Compensation

The ADE7763 incorporates a Channel 2 rms offset compensation register (VRMSOS). This is a 12-bit, signed register that can be used to remove offset in the Channel 2 rms calculation. An offset could exist in the rms calculation due to input noises and dc offset in the input samples. One LSB of the Channel 2 rms offset is equivalent to 1 LSB of the rms register. Assuming that the maximum value of the Channel 2 rms calculation is 1,561,400d with full-scale ac inputs, then 1 LSB of the Channel 2 rms offset represents 0.064% of measurement error at -60 dB down of full scale.

$$VRMS = VRMS_0 + VRMSOS \tag{6}$$

where VRMS₀ is the rms measurement without offset correction.

The voltage rms offset compensation should be done by testing the rms results at two nonzero input levels. One measurement can be done close to full scale and the other at approximately full scale/10. The voltage offset compensation can be derived from these measurements. If the voltage rms offset register does not have enough range, the CH2OS register can also be used.

PHASE COMPENSATION

When the HPF is disabled, the phase error between Channel 1 and Channel 2 is 0 from dc to 3.5 kHz. When HPF is enabled, Channel 1 has the phase response illustrated in Figure 50 and

Figure 51. Figure 52 shows the magnitude response of the filter. As seen from the plots, the phase response is almost 0 from 45 Hz to 1 kHz, which is all that is required in typical energy measurement applications. However, despite being internally phase-compensated, the ADE7763 must work with transducers, which could have inherent phase errors. For example, a phase error of 0.1° to 0.3° is not uncommon for a current transformer (CT). Phase errors can vary from part to part and must be corrected in order to perform accurate power calculations. The errors associated with phase mismatch are particularly noticeable at low power factors. The ADE7763 provides a means of digitally calibrating these small phase errors by allowing a short time delay or time advance to be introduced into the signal processing chain to compensate for these errors. Because the compensation is in time, this technique should only be used for small phase errors in the range of 0.1° to 0.5°. Correcting large phase errors using a time shift technique can introduce significant phase errors at higher harmonics.

The phase calibration register (PHCAL[5:0]) is a two's complement, signed, single-byte register that has values ranging from 0x21 (-31d) to 0x1F (+31d).

The register is centered at 0Dh, so that writing 0Dh to the register produces 0 delay. By changing the PHCAL register, the time delay in the Channel 2 signal path can change from -102.12 μs to +39.96 μs (CLKIN = 3.579545 MHz). One LSB is equivalent to 2.22 μs (CLKIN/8) time delay or advance. A line frequency of 60 Hz gives a phase resolution of 0.048° at the fundamental (i.e., 360° × 2.22 μs × 60 Hz). Figure 49 illustrates how the phase compensation is used to remove a 0.1° phase lead in Channel 1 due to the external transducer. To cancel the lead (0.1°) in Channel 1, a phase lead must also be introduced into Channel 2. The resolution of the phase adjustment allows the introduction of a phase lead in increments of 0.048°. The phase lead is achieved by introducing a time advance in Channel 2. A time advance of 4.44 μs is made by writing -2 (0x0B) to the time delay block, thus reducing the amount of time delay by 4.44 μs, or equivalently, a phase lead of approximately 0.1° at line frequency of 60 Hz. 0x0B represents -2 because the register is centered with 0 at 0Dh.

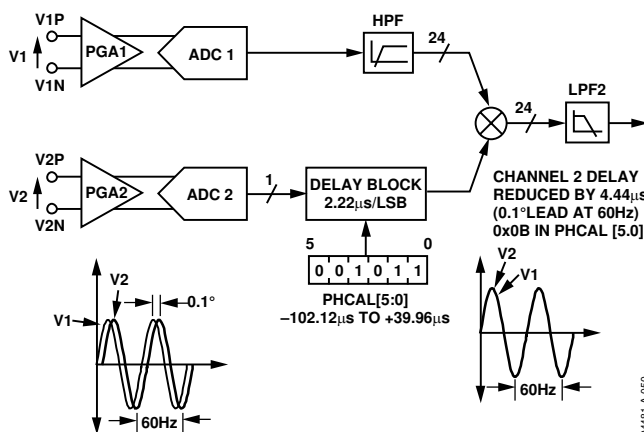

Figure 49. Phase Calibration

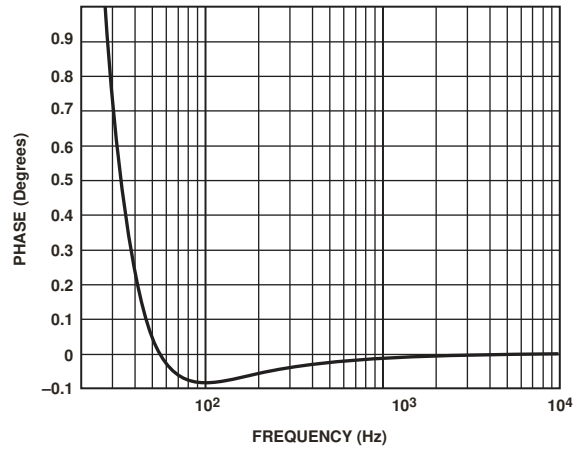

Figure 50. Combined Phase Response of HPF and Phase Compensation (10 Hz to 1 kHz)

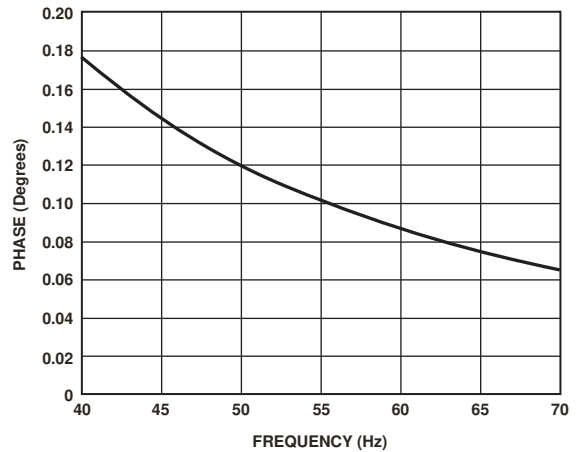

Figure 51. Combined Phase Response of HPF and Phase Compensation (40 Hz to 70 Hz)

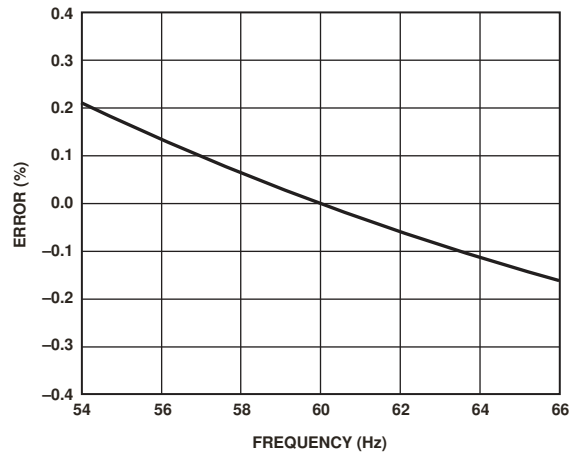

Figure 52. Combined Gain Response of HPF and Phase Compensation

ACTIVE POWER CALCULATION

Power is defined as the rate of energy flow from the source to the load. It is defined as the product of the voltage and current waveforms. The resulting waveform is called the instantaneous power signal and is equal to the rate of energy flow at any given time. The unit of power is the watt or joules/s. Equation 9 gives an expression for the instantaneous power signal in an ac system.

$$v(t) = \sqrt{2} \times V \sin(\omega t) \tag{7}$$

$$i(t) = \sqrt{2} \times I \sin(\omega t) \tag{8}$$

where:

V is the rms voltage.

I is the rms current.

$$p(t) = v(t) \times i(t)$$

$$p(t) = VI - VI \cos(2\omega t) \tag{9}$$

The average power over an integral number of line cycles (n) is given by the expression in Equation 10.

$$P = \frac{1}{nT} \int_0^{nT} p(t) dt = VI \tag{10}$$

where:

T is the line cycle period.

P is the active or real power.

Note that the active power is equal to the dc component of the instantaneous power signal $p(t)$ in Equation 8, i.e., VI . This is the relationship used to calculate active power in the ADE7763. The instantaneous power signal $p(t)$ is generated by multiplying the current and voltage signals. The dc component of the instantaneous power signal is then extracted by LPF2 (low-pass filter) to obtain the active power information. This process is illustrated in Figure 53.

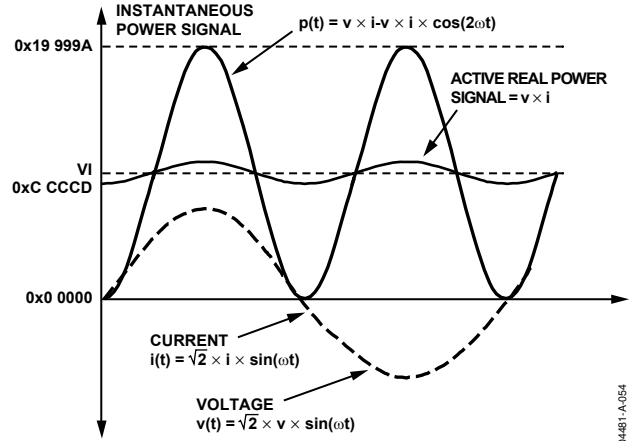

Figure 53. Active Power Calculation

04481-A-054

Because LPF2 does not have an ideal “brick wall” frequency response (see Figure 54), the active power signal has some ripple due to the instantaneous power signal. This ripple is sinusoidal and has a frequency equal to twice the line frequency. Because the ripple is sinusoidal in nature, it is removed when the active power signal is integrated to calculate energy—see the Energy Calculation section.

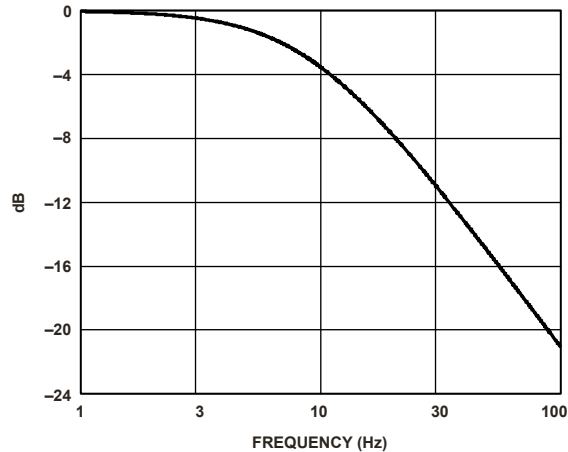

Figure 54. Frequency Response of LPF2

04481-A-055

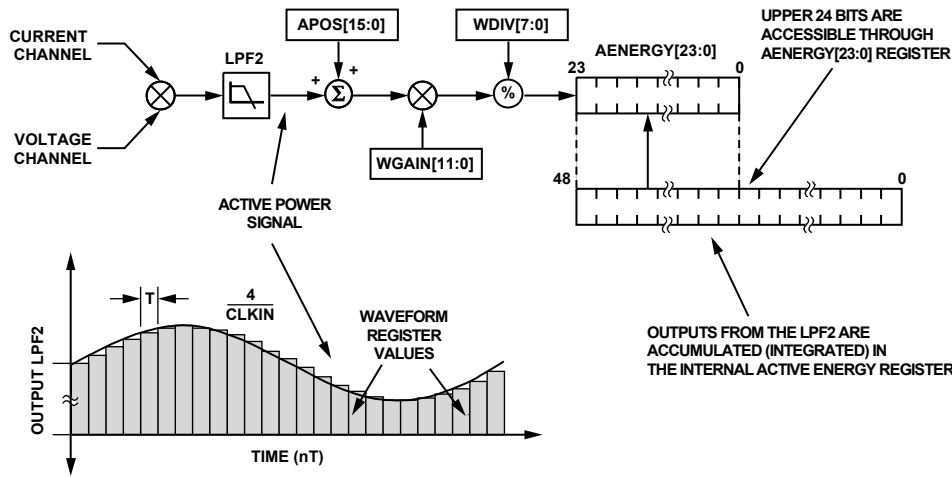

Figure 55. Active Energy Calculation

Figure 55 shows the signal processing chain for the active power calculation. The active power is calculated by low-pass filtering the instantaneous power signal. Note that when reading the waveform samples from the output of LPF2, the gain of the active energy can be adjusted by using the multiplier and watt gain register (WGAIN[11:0]). The gain is adjusted by writing a two's complement 12-bit word to the watt gain register. Equation 11 shows how the gain adjustment is related to the contents of the watt gain register:

$$Output\ WGAIN = \left(Active\ Power \times \left\{ 1 + \frac{WGAIN}{2^{12}} \right\} \right) \quad (11)$$

For example, when 0x7FF is written to the watt gain register, the power output is scaled up by 50%. $0x7FF = 2047d$, $2047/2^{12} = 0.5$. Similarly, $0x800 = -2048d$ (signed two's complement) and power output is scaled by -50%. Each LSB scales the power output by 0.0244%. Figure 56 shows the maximum code (hexadecimal) output range for the active power signal (LPF2). Note that the output range changes depending on the contents of the watt gain register. The minimum output range is given when the watt gain register contents are equal to 0x800, and the maximum range is given by writing 0x7FF to the watt gain register. This can be used to calibrate the active power (or energy) calculation.

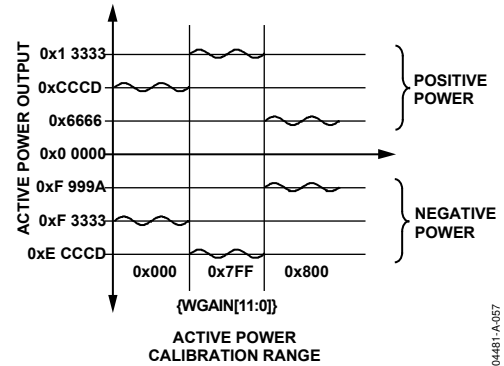

Figure 56. Active Power Calculation Output Range

ENERGY CALCULATION

As stated earlier, power is defined as the rate of energy flow. This relationship is expressed mathematically in Equation 12.

$$P = \frac{dE}{dt} \quad (12)$$

where:

P is power.
 E is energy.

Conversely, energy is given as the integral of power.

$$E = \int P dt \quad (13)$$

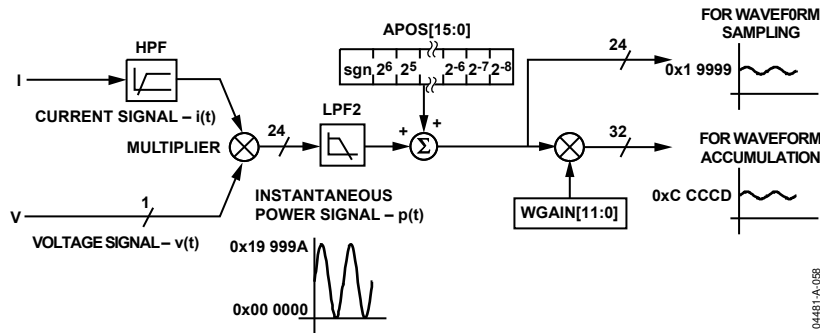

Figure 57. Active Power Signal Processing

The ADE7763 achieves the integration of the active power signal by continuously accumulating the active power signal in an internal unreadable 49-bit energy register. The active energy register (AENERGY[23:0]) represents the upper 24 bits of this internal register. This discrete time accumulation or summation is equivalent to integration in continuous time. Equation 14 expresses this relationship.

$$E = \int p(t)dt = \lim_{T \rightarrow 0} \left\{ \sum_{n=1}^{\infty} p(nT) \times T \right\} \quad (14)$$

where:

n is the discrete time sample number.

T is the sample period.

The discrete time sample period (T) for the accumulation register is $1.1 \mu\text{s}$ ($4/\text{CLKIN}$). In addition to calculating the energy, this integration removes any sinusoidal components that might be in the active power signal.

Figure 57 shows this discrete time integration, or accumulation. The active power signal in the waveform register is continuously added to the internal active energy register. This addition is a signed addition; therefore, negative energy is subtracted from the active energy contents. The exception to this is when POAM is selected in the MODE[15:0] register, in which case only positive energy contributes to the active energy accumulation—see the Positive-Only Accumulation Mode section.

The output of the multiplier is divided by WDIV. If the value in the WDIV register is equal to 0, then the internal active energy register is divided by 1. WDIV is an 8-bit, unsigned register. After dividing by WDIV, the active energy is accumulated in a 49-bit internal energy accumulation register. The upper 24 bits of this register are accessible through a read to the active energy register (AENERGY[23:0]). A read to the RAENERGY register returns the content of the AENERGY register, and the upper 24 bits of the internal register are cleared. As shown in Figure 57, the active power signal is accumulated in an internal 49-bit, signed register. The active power signal can be read from the

waveform register by setting MODE[14:13] = 0, 0 and setting the WSMP bit (Bit 3) in the interrupt enable register to 1. Like Channel 1 and Channel 2 waveform sampling modes, the waveform data is available at sample rates of 27.9 kSPS, 14 kSPS, 7 kSPS, or 3.5 kSPS—see Figure 44. The active power waveform sampling signal has a settling time of approximately 2 ms.

Figure 58 shows this energy accumulation for full-scale signals (sinusoidal) on the analog inputs. The three curves illustrate the minimum time for the energy register to roll over when the active power gain register contents are 0x7FF, 0x000, and 0x800. The watt gain register is used to carry out power calibration. As shown, the fastest integration time occurs when the watt gain register is set to maximum full scale, i.e., 0x7FF.

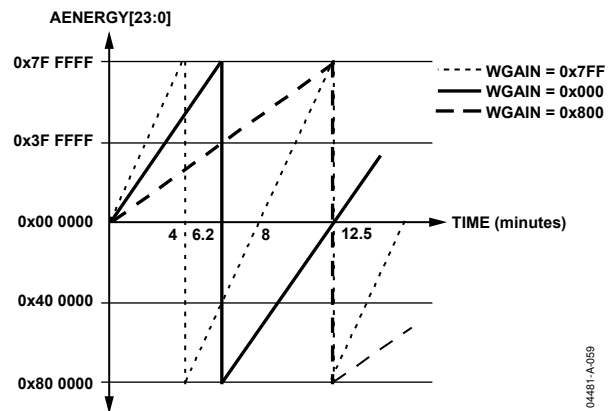

Figure 58. Energy Register Rollover Time for Full-Scale Power (Minimum and Maximum Power Gain)

Note that the energy register contents roll over to full-scale negative (0x80 0000) and continue increasing in value when the power or energy flow is positive—see Figure 58. Conversely, if the power was negative, the energy register would underflow to full-scale positive (0x7F FFFF) and continue decreasing in value.

By using the interrupt enable register, the ADE7763 can be configured to issue an interrupt (IRQ) when the active energy register is more than half full (positive or negative), or when an overflow or underflow occurs.

Integration Time under Steady Load

As mentioned in the last section, the discrete time sample period (T) for the accumulation register is $1.1 \mu\text{s}$ ($4/\text{CLKIN}$). With full-scale sinusoidal signals on the analog inputs and the WGAIN register set to $0\text{x}000$, the average word value from each LPF2 is $0\text{x}C\text{CCCC}$ —see Figure 53. The maximum positive value that can be stored in the internal 49-bit register before it overflows is 2^{48} , or $0\text{x}\text{FFFF FFFF FFFF}$. The integration time under these conditions with $\text{WDIV} = 0$ is calculated as follows:

$$\text{Time} = \frac{0\text{x}\text{FFFF FFFF FFFF}}{0\text{x}C\text{CCCC}} \times 1.12 \mu\text{s} = 375.8 \text{ s} = 6.26 \text{ min} \quad (15)$$

When WDIV is set to a value other than 0, the integration time varies, as shown in Equation 16.

$$\text{Time} = \text{Time}_{\text{WDIV}=0} \times \text{WDIV} \quad (16)$$

POWER OFFSET CALIBRATION

The ADE7763 incorporates an active power offset register ($\text{APOS}[15:0]$). This is a signed, twos complement, 16-bit register that can be used to remove offsets in the active power calculation—see Figure 57. An offset could exist in the power calculation due to crosstalk between channels on the PCB or in the IC itself.

The 256 LSBs ($\text{APOS} = 0\text{x}0100$) written to the active power offset register are equivalent to 1 LSB in the waveform sample register. Assuming the average value output from LPF2 is $0\text{x}C\text{CCCC}$ ($838,861\text{d}$) when inputs on Channels 1 and 2 are both at full scale. At -60 dB down on Channel 1 ($1/1000$ of the Channel 1 full-scale input), the average word value output from LPF2 is 838.861 ($838,861/1,000$). One LSB in the LPF2 output has a measurement error of $1/838.861 \times 100\% = 0.119\%$ of the average value. The active power offset register has a resolution equal to $1/256$ LSB of the waveform register; therefore, the power offset correction resolution is $0.00047\%/ \text{LSB}$ ($0.119\%/256$) at -60 dB .

ENERGY-TO-FREQUENCY CONVERSION

The ADE7763 provides energy-to-frequency conversion for calibration purposes. After initial calibration at manufacturing, the manufacturer or end customer often verifies the energy meter calibration. One convenient way to verify the meter calibration is for the manufacturer to provide an output frequency, which is proportional to the energy or active power under steady load conditions. This output frequency can provide a simple, single-wire, optically isolated interface to external calibration equipment. Figure 59 illustrates the energy-to-frequency conversion.

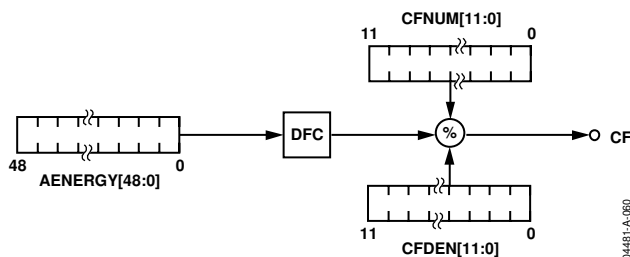

Figure 59. Energy-to-Frequency Conversion

A digital-to-frequency converter (DFC) is used to generate the CF pulsed output. The DFC generates a pulse each time 1 LSB in the active energy register is accumulated. An output pulse is generated when $(\text{CFDEN} + 1)/(\text{CFNUM} + 1)$ number of pulses are generated at the DFC output. Under steady load conditions, the output frequency is proportional to the active power.

The maximum output frequency, with ac input signals at full scale, $\text{CFNUM} = 0\text{x}00$, and $\text{CFDEN} = 0\text{x}00$, is approximately 23 kHz .

There are two unsigned, 12-bit registers, $\text{CFNUM}[11:0]$ and $\text{CFDEN}[11:0]$, that can be used to set the CF frequency to a wide range of values. These frequency-scaling registers are 12-bit registers that can scale the output frequency by $1/2^{12}$ to 1 with a step of $1/2^{12}$.

If the value 0 is written to any of these registers, the value 1 will be applied to the register. The ratio $(\text{CFNUM} + 1)/(\text{CFDEN} + 1)$ should be smaller than 1 to ensure proper operation. If the ratio of the registers $(\text{CFNUM} + 1)/(\text{CFDEN} + 1)$ is greater than 1, the register values will be adjusted to a ratio $(\text{CFNUM} + 1)/(\text{CFDEN} + 1)$ of 1. For example, if the output frequency is 1.562 kHz while the contents of CFDEN are 0 ($0\text{x}000$), then the output frequency can be set to 6.1 Hz by writing $0\text{x}\text{FF}$ to the CFDEN register.

When CFNUM and CFDEN are both set to one, the CF pulse width is fixed at $16 \text{ CLKIN}/4$ clock cycles, approximately $18 \mu\text{s}$ with a CLKIN of 3.579545 MHz . If the CF pulse output is longer than 180 ms for an active energy frequency of less than 5.56 Hz , the pulse width is fixed at 90 ms . Otherwise, the pulse width is 50% of the duty cycle.

The output frequency has a slight ripple at a frequency equal to twice the line frequency. This is due to imperfect filtering of the instantaneous power signal to generate the active power signal—see the Active Power Calculation section. Equation 8 gives an expression for the instantaneous power signal. This is filtered by LPF2 , which has a magnitude response given by Equation 17.

$$|H(f)| = \frac{1}{\sqrt{1 + \frac{f^2}{8.9^2}}} \quad (17)$$

The active power signal (output of LPF2) can be rewritten as

$$p(t) = VI - \left[\frac{VI}{\sqrt{1 + \left(\frac{2f_L}{8.9}\right)^2}} \right] \times \cos(4\pi f_L t) \quad (18)$$

where f_L is the line frequency, for example, 60 Hz.

From Equation 13,

$$E(t) = VI t - \left[\frac{VI}{4\pi f_L \sqrt{1 + \left(\frac{2f_L}{8.9}\right)^2}} \right] \times \sin(4\pi f_L t) \quad (19)$$

Note that in Equation 19 there is a small ripple in the energy calculation due to a $\sin(2\omega t)$ component. This is shown graphically in Figure 60. The active energy calculation is represented by the dashed, straight line and is equal to $V \times I \times t$. The sinusoidal ripple in the active energy calculation is also shown. Because the average value of a sinusoid is 0, the ripple does not contribute to the energy calculation over time. However, the ripple might be observed in the frequency output, especially at

higher output frequencies. The ripple becomes larger as a percentage of the frequency at larger loads and higher output frequencies. This occurs because the integration or averaging time in the energy-to-frequency conversion process is shorter at higher output frequencies. Consequently, some of the sinusoidal ripple in the energy signal is observable in the frequency output. Choosing a lower output frequency at CF for calibration can significantly reduce the ripple. Also, averaging the output frequency by using a longer gate time for the counter achieves the same results.

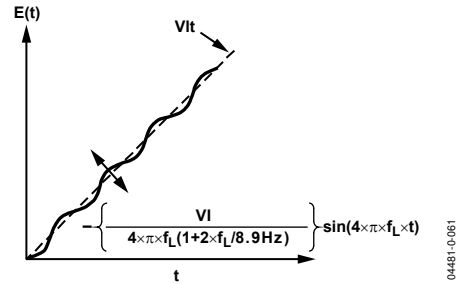

Figure 60. Output Frequency Ripple

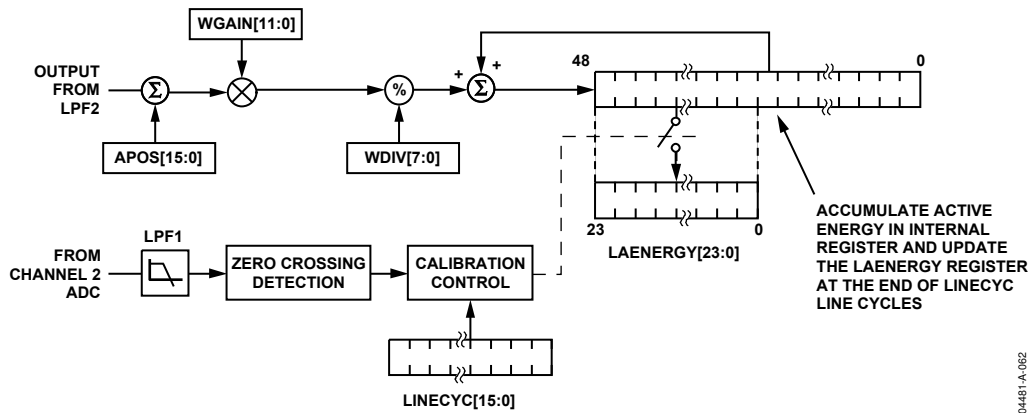

Figure 61. Energy Calculation Line Cycle Energy Accumulation Mode

LINE CYCLE ENERGY ACCUMULATION MODE

In line cycle energy accumulation mode, the energy accumulation of the ADE7763 can be synchronized to the Channel 2 zero crossing so that active energy accumulates over an integral number of half line cycles. The advantage of summing the active energy over an integral number of line cycles is that the sinusoidal component in the active energy is reduced to 0. This eliminates ripple in the energy calculation. Energy is calculated more accurately and in a shorter time because the integration period is shortened. By using the line cycle energy accumulation mode, the energy calibration can be greatly simplified, and the time required to calibrate the meter can be significantly reduced. The ADE7763 is placed in line cycle energy accumulation mode by setting Bit 7 (CYCMODE) in the mode register. In line cycle energy accumulation mode, the ADE7763 accumulates the active power signal in the LAENERGY register (Address 0x04) for an integral number of line cycles, as shown in Figure 61. The number of half line cycles is specified in the LINECYC register (Address 0x1C). The ADE7763 can accumulate active power for up to 65,535 half line cycles. Because the active power is integrated on an integral number of line cycles, the CYCEND flag in the interrupt status register is set (Bit 2) at the end of a line cycle energy accumulation cycle. If the CYCEND enable bit in the interrupt enable register is enabled, the $\overline{\text{IRQ}}$ output also will go active low. Therefore, the $\overline{\text{IRQ}}$ line can also be used to signal the completion of the line cycle energy accumulation. Another calibration cycle can start as long as the CYCMODE bit in the mode register is set.

From Equations 13 and 18,

$$E(t) = \int_0^{nT} VI dt - \left\{ \frac{VI}{\sqrt{1 + \left(\frac{f}{8.9}\right)^2}} \right\} \times \int_0^{nT} \cos(2\pi f t) dt \quad (20)$$

where:

n is an integer.

T is the line cycle period.

Since the sinusoidal component is integrated over an integral number of line cycles, its value is always 0. Therefore,

$$E = \int_0^{nT} VI dt + 0 \quad (21)$$

$$E(t) = VI nT \quad (22)$$

Note that in this mode, the 16-bit LINECYC register can hold a maximum value of 65,535. In other words, the line energy accumulation mode can be used to accumulate active energy for a maximum duration of 65,535 half line cycles. At 60 Hz line frequency, this translates to a total duration of 65,535/120 Hz = 546 seconds.

POSITIVE-ONLY ACCUMULATION MODE

In positive-only accumulation mode, the active energy accumulation is only done for positive power, ignoring any occurrence of negative power above or below the no-load threshold, as shown in Figure 62. The CF pulse also reflects this accumulation method when in this mode. Positive-only accumulation mode is activated by setting the MSB of the mode register (MODE[15]) and effects only the active power. The default setting for this mode is off. Transitions in the direction of power flow, going from negative to positive or positive to negative, set the IRQ pin to active low if the PPOS and PNEG bits are set in the interrupt enable register. The corresponding PPOS and PNEG bits in the interrupt status register show which transition has occurred—see the register descriptions in Table 9.

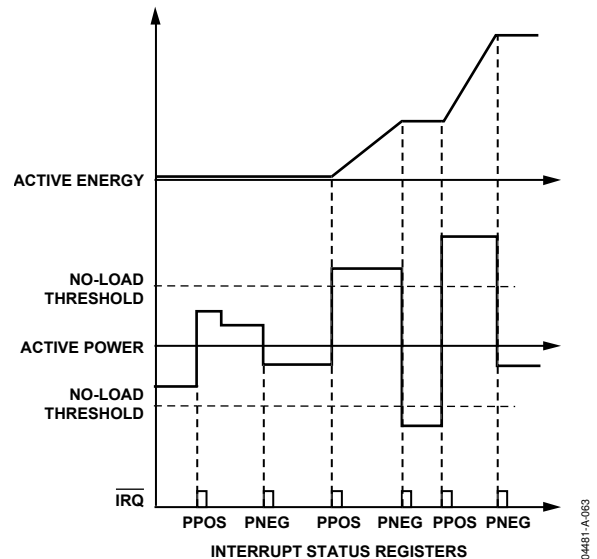

Figure 62. Energy Accumulation in Positive-Only Accumulation Mode

NO-LOAD THRESHOLD

The ADE7763 includes a no-load threshold feature on the active energy that eliminates any creep effects in the meter. This is accomplished because energy does not accumulate if the multiplier output is below the no-load threshold. This threshold is 0.001% of the full-scale output frequency of the multiplier. Compare this value to the IEC1036 specification, which states that the meter must start up with a load equal to or less than 0.4% I_b . This standard translates to 0.0167% of the full-scale output frequency of the multiplier.

APPARENT POWER CALCULATION

The apparent power is the maximum power that can be delivered to a load. V_{rms} and I_{rms} are the effective voltage and current delivered to the load; the apparent power (AP) is defined as $V_{rms} \times I_{rms}$. The angle θ between the active power and the apparent power generally represents the phase shift due to nonresistive loads. For single-phase applications, θ represents the angle between the voltage and the current signals—see Figure 63. Equation 24 gives an expression of the instantaneous power signal in an ac system with a phase shift.

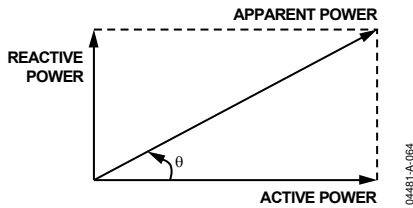

Figure 63. Power Triangle

$$v(t) = \sqrt{2} V_{rms} \sin(\omega t)$$

$$i(t) = \sqrt{2} I_{rms} \sin(\omega t + \theta) \tag{23}$$

$$p(t) = v(t) \times i(t)$$

$$p(t) = V_{rms} I_{rms} \cos(\theta) - V_{rms} I_{rms} \cos(2\omega t + \theta) \tag{24}$$

The apparent power is defined as $V_{rms} \times I_{rms}$. This expression is independent from the phase angle between the current and the voltage.

Figure 64 illustrates the signal processing in each phase for the calculation of the apparent power in the ADE7763.

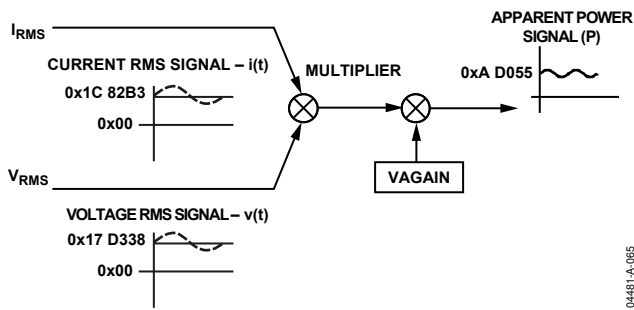

Figure 64. Apparent Power Signal Processing

The gain of the apparent energy can be adjusted by using the multiplier and VAGAIN register (VAGAIN[11:0]). The gain is adjusted by writing a twos complement, 12-bit word to the VAGAIN register. Equation 25 shows how the gain adjustment is related to the contents of the VAGAIN register.

$$OutputVAGAIN = \left(Apparent\ Power \times \left\{ 1 + \frac{VAGAIN}{2^{12}} \right\} \right) \tag{25}$$

For example, when 0x7FF is written to the VAGAIN register, the power output is scaled up by 50%. $0x7FF = 2047d$, $2047/2^{12} = 0.5$. Similarly, $0x800 = -2047d$ (signed, twos complement) and power output is scaled by -50%. Each LSB represents 0.0244% of the power output. The apparent power is calculated with the current and voltage rms values obtained in the rms blocks of the ADE7763. Figure 65 shows the maximum code (hexadecimal) output range of the apparent power signal. Note that the output range changes depending on the contents of the apparent power gain registers. The minimum output range is given when the apparent power gain register content is equal to 0x800; the maximum range is given by writing 0x7FF to the apparent power gain register. This can be used to calibrate the apparent power (or energy) calculation in the ADE7763.

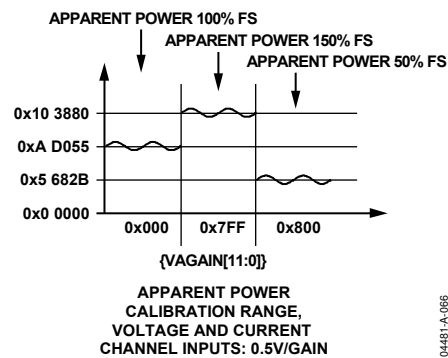

Figure 65. Apparent Power Calculation Output Range

Apparent Power Offset Calibration

Each rms measurement includes an offset compensation register to calibrate and eliminate the dc component in the rms value—see the Channel 1 RMS Calculation and Channel 2 RMS Calculation sections. The Channel 1 and Channel 2 rms values are then multiplied together in the apparent power signal processing. Because no additional offsets are created in the multiplication of the rms values, there is no specific offset compensation in the apparent power signal processing. The offset compensation of the apparent power measurement is done by calibrating each individual rms measurement.

APPARENT ENERGY CALCULATION

The apparent energy is given as the integral of the apparent power.

$$Apparent\ Energy = \int Apparent\ Power(t) dt \quad (26)$$

The ADE7763 achieves the integration of the apparent power signal by continuously accumulating the apparent power signal in an internal 49-bit register. The apparent energy register (VAENERGY[23:0]) represents the upper 24 bits of this internal register. This discrete time accumulation or summation is equivalent to integration in continuous time. Equation 29 expresses this relationship.

$$Apparent\ Energy = \lim_{T \rightarrow 0} \left\{ \sum_{n=0}^{\infty} Apparent\ Power(nT) \times T \right\} \quad (27)$$

where:

n is the discrete number of time samples.

T is the time sample period.

The discrete time sample period (*T*) for the accumulation register is 1.1 μs (4/CLKIN).

Figure 66 shows this discrete time integration or accumulation. The apparent power signal is continuously added to the internal register. This addition is a signed addition, even if the apparent energy always remains positive in theory.

The 49 bits of the internal register are divided by VADIV. If the value in the VADIV register is 0, then the internal active energy register is divided by 1. VADIV is an 8-bit, unsigned register. The upper 24 bits are then written in the 24-bit apparent energy register (VAENERGY[23:0]). RVAENERGY register (24 bits long) is provided to read the apparent energy. This register is reset to 0 after a read operation.

Figure 67 shows this apparent energy accumulation for full-scale signals (sinusoidal) on the analog inputs. The three curves illustrate the minimum time for the energy register to roll over when the VAGAIN registers content is equal to 0x7FF, 0x000, and 0x800. The VAGAIN register is used to carry out an apparent power calibration. As shown in the figure, the fastest integration time occurs when the VAGAIN register is set to maximum full scale, i.e., 0x7FF.

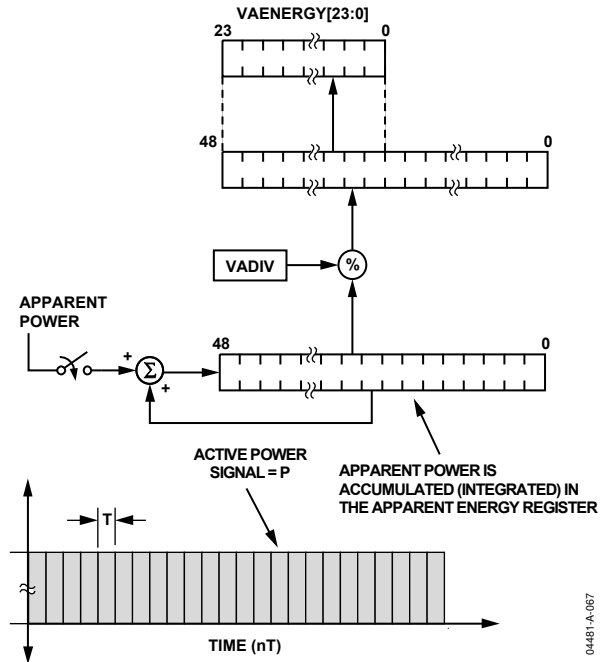

Figure 66. Apparent Energy Calculation

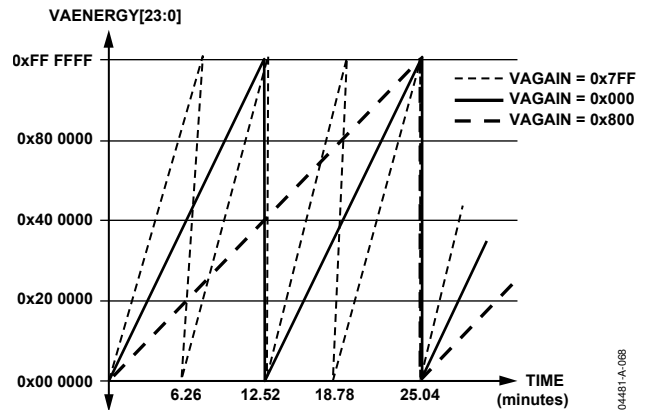

Figure 67. Energy Register Rollover Time for Full-Scale Power (Maximum and Minimum Power Gain)

Note that the apparent energy register is unsigned—see Figure 67. By using the interrupt enable register, the ADE7763 can be configured to issue an interrupt (IRQ) when the apparent energy register is more than half full or when an overflow occurs. The half full interrupt for the unsigned apparent energy register is based on 24 bits, as opposed to 23 bits for the signed active energy register.

Integration Times under Steady Load

As mentioned in the last section, the discrete time sample period (T) for the accumulation register is $1.1 \mu s$ ($4/CLKIN$). With full-scale sinusoidal signals on the analog inputs and the VAGAIN register set to $0x000$, the average word value from the apparent power stage is $0xA D055$. The maximum value that can be stored in the apparent energy register before it overflows is 2^{24} or $0xFF FFFF$. The average word value is added to the internal register, which can store 2^{48} or $0xFFFF FFFF FFFF$ before it overflows. Therefore, the integration time under these conditions with $VADIV = 0$ is calculated as follows:

$$Time = \frac{0xFFFF FFFF FFFF}{0xAD055} \times 1.2 \mu s = 888 s = 12.52 \text{ min} \quad (28)$$

When $VADIV$ is set to a value other than 0, the integration time varies, as shown in Equation 29.

$$Time = Time_{VADIV=0} \times VADIV \quad (29)$$

LINE APPARENT ENERGY ACCUMULATION

The ADE7763 is designed with a special apparent energy accumulation mode, which simplifies the calibration process.

By using the on-chip zero-crossing detection, the ADE7763 accumulates the apparent power signal in the LVAENERGY register for an integral number of half cycles, as shown in Figure 68. The line apparent energy accumulation mode is always active.

The number of half line cycles is specified in the LINECYC register, which is an unsigned, 16-bit register. The ADE7763 can accumulate apparent power for up to 65,535 combined half cycles. Because the apparent power is integrated on the same integral number of line cycles as the line active energy register, these two values can be easily compared. The active and apparent energies are calculated more accurately because of this precise timing control. At the end of an energy calibration cycle, the CYCEND flag in the interrupt status register is set. If the CYCEND mask bit in the interrupt mask register is enabled, the \overline{IRQ} output also will go active low. Thus, the \overline{IRQ} line can also be used to signal the end of a calibration.

The line apparent energy accumulation uses the same signal path as the apparent energy accumulation. The LSB size of these two registers is equivalent.

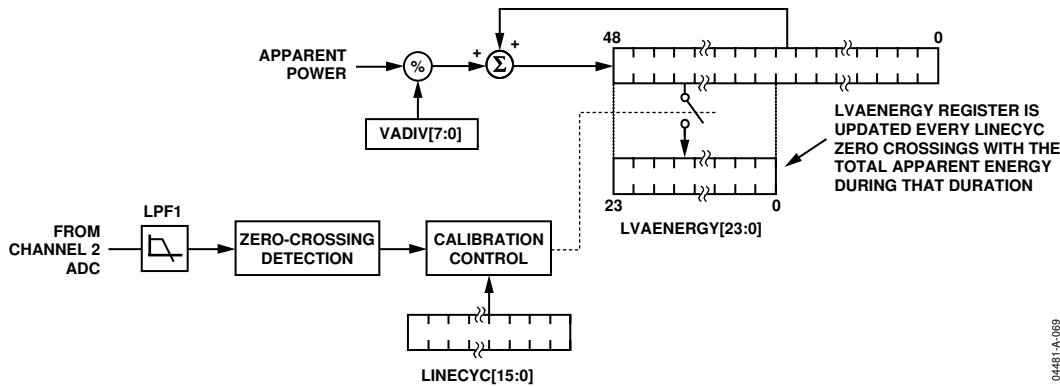

Figure 68. Apparent Energy Calibration

04481-A-069

ENERGIES SCALING

The ADE7763 provides measurements of active and apparent energies. These measurements do not have the same scaling and therefore cannot be compared directly to each other.

Table 7. Energies Scaling

	PF = 1	PF = 0.707	PF = 0
Integrator on at 50 Hz			
Active	Wh	Wh × 0.707	0
Apparent	Wh × 0.848	Wh × 0.848	Wh × 0.848
Integrator off at 50 Hz			
Active	Wh	Wh × 0.707	0
Apparent	Wh × 0.848	Wh × 0.848	Wh × 0.848
Integrator on at 60 Hz			
Active	Wh	Wh × 0.707	0
Apparent	Wh × 0.827	Wh × 0.827	Wh × 0.827
Integrator off at 60 Hz			
Active	Wh	Wh × 0.707	0
Apparent	Wh × 0.827	Wh × 0.827	Wh × 0.827

CALIBRATING AN ENERGY METER

The ADE7763 provides gain and offset compensation for active and apparent energy calibration. Its phase compensation corrects phase error in active and apparent energy. If a shunt is used, offset and phase calibration may not be required. A reference meter or an accurate source can be used to calibrate the ADE7763.

When using a reference meter, the ADE7763 calibration output frequency, CF, is adjusted to match the frequency output of the reference meter. A pulse output is only provided for the active

energy measurement in the ADE7763. If a reference meter is used to calibrate the VA, then additional code must be written in a microprocessor to produce a pulsed output for this quantity. Otherwise, VA calibration requires an accurate source.

The ADE7763 provides a line cycle accumulation mode for calibration using an accurate source. In this method, the active energy accumulation rate is adjusted to produce a desired CF frequency. The benefit of using this mode is that the effect of the ripple noise on the active energy is eliminated. Up to 65,535 half line cycles can be accumulated, therefore providing a stable energy value to average. The accumulation time is calculated from the line cycle period, measured by the period register, and the number of half line cycles in the accumulation, fixed by the LINECYC register.

Current and voltage rms offset calibration removes apparent energy offset. A gain calibration is also provided for apparent energy. Figure 70 shows an optimized calibration flow for active energy, rms, and apparent energy.

Active and apparent energy gain calibrations can take place concurrently, with a read of the accumulated apparent energy register following that of the accumulated active energy register.

Figure 69 shows the calibration flow for the active energy portion of the ADE7763.



Figure 69. Active Energy Calibration

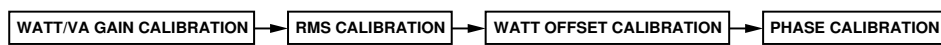

Figure 70. Apparent and Active Energy Calibration

Watt Gain

The first step of calibrating the gain is to define the line voltage, the base current, and the maximum current for the meter. A meter constant, such as 3200 imp/kWh or 3.2 imp/Wh, needs to be determined for CF. Note that the line voltage and the maximum current scale to half of their respective analog input ranges in this example.

The expected CF in Hz is

$$CF_{expected} \text{ (Hz)} = \frac{\text{MeterConstant}(\text{imp/Wh}) \times \text{Load}(\text{W})}{3600 \text{ s/h}} \times \cos(\varphi) \quad (30)$$

where:

φ is the angle between I and V.
 $\cos(\varphi)$ is the power factor.

The ratio of active energy LSBs per CF pulse is adjusted using the CFNUM, CFDEN, and WDIV registers.

$$CF_{expected} = \frac{LAENERGY}{\text{AccumulationTime}(\text{s})} \times WDIV \times \frac{(CFNUM + 1)}{(CFDEN + 1)} \quad (31)$$

The relationship between watt-hours accumulated and the quantity read from AENERGY can be determined from the amount of active energy accumulated over time with a given load:

$$\text{Wh/LSB} = \frac{\text{Load}(\text{W}) \times \text{Accumulation Time}(\text{s})}{LAENERGY \times 3600 \text{ s/h}} \quad (32)$$

where *Accumulation Time* can be determined from the value in the line period and the number of half line cycles fixed in the LINECYC register.

$$\text{Accumulation time}(\text{s}) = \frac{LINECYC_{IB} \times \text{Line Period}(\text{s})}{2} \quad (33)$$

The line period can be determined from the period register:

$$\text{Line Period}(\text{s}) = PERIOD \times \frac{8}{CLKIN} \quad (34)$$

The AENERGY Wh/LSB ratio can also be expressed in terms of the meter constant:

$$\text{Wh/LSB} = \frac{\frac{(CFNUM + 1)}{(CFDEN + 1)} \times WDIV}{\text{MeterConstant}(\text{imp/Wh})} \quad (35)$$

In a meter design, WDIV, CFNUM, and CFDEN should be kept constant across all meters to ensure that the Wh/LSB constant is maintained. Leaving WDIV at its default value of 0 ensures maximum resolution. The WDIV register is not included in the CF signal chain, so it does not affect the frequency pulse output.

The WGAIN register is used to finely calibrate each meter. Calibrating the WGAIN register changes both CF and AENERGY for a given load condition.

$$AENERGY_{expected} = AENERGY_{nominal} \times \left(1 + \frac{WGAIN}{2^{12}}\right) \quad (36)$$

$$CF_{expected} \text{ (Hz)} = CF_{nominal} \times \frac{(CFNUM + 1)}{(CFDEN + 1)} \times \left(1 + \frac{WGAIN}{2^{12}}\right) \quad (37)$$

When calibrating with a reference meter, WGAIN is adjusted until CF matches the reference meter pulse output. If an accurate source is used to calibrate, WGAIN will be modified until the active energy accumulation rate yields the expected CF pulse rate.

The steps of designing and calibrating the active energy portion of a meter with either a reference meter or an accurate source are outlined in the following examples. The specifications for this example are

Meter Constant:	$\text{MeterConstant}(\text{imp/Wh}) = 3.2$
Base Current:	$I_b = 10 \text{ A}$
Maximum Current:	$I_{MAX} = 60 \text{ A}$
Line Voltage:	$V_{nominal} = 220 \text{ V}$
Line Frequency:	$f_l = 50 \text{ Hz}$

The first step in calibration with either a reference meter or an accurate source is to calculate the CF denominator, CFDEN. This is done by comparing the expected CF pulse output to the nominal CF output with the default CFDEN = 0x3F and CFNUM = 0x3F when the base current is applied.

The expected CF output for this meter with the base current applied is 1.9556 Hz using Equation 30.

$$CF_{IB(expected)} \text{ (Hz)} = \frac{3.200 \text{ imp/Wh} \times 10 \text{ A} \times 220 \text{ V}}{3600 \text{ s/h}} \times \cos(\varphi) = 1.9556 \text{ Hz}$$

Alternatively, $CF_{expected}$ can be measured from a reference meter pulse output.

$$CF_{expected} \text{ (Hz)} = CF_{ref} \quad (38)$$

The maximum CF frequency measured without any frequency division and with ac inputs at full scale is 23 kHz. For this example, the nominal CF with the test current, I_b , applied is 958 Hz. In this example the line voltage and maximum current scale half of their respective analog input ranges. The line voltage and maximum current should not be fixed at the maximum analog inputs to account for occurrences such as spikes on the line.

$$CF_{nominal} \text{ (Hz)} = 23 \text{ kHz} \times \frac{1}{2} \times \frac{1}{2} \times \frac{I}{I_{MAX}} \quad (39)$$

$$CF_{IB(nominal)} \text{ (Hz)} = 23 \text{ kHz} \times \frac{1}{2} \times \frac{1}{2} \times \frac{10}{60} = 958 \text{ Hz}$$

The nominal CF on a sample set of meters should be measured using the default CFDEN, CFNUM, and WDIV to ensure that the best CFDEN is chosen for the design.

With the CFNUM register set to 0, CFDEN is calculated to be 489 for the example meter:

$$CFDEN = INT\left(\frac{CF_{IB(nominal)}}{CF_{IB(expected)}}\right) - 1 \quad (40)$$

$$CFDEN = INT\left(\frac{958}{1.9556}\right) - 1 = (490 - 1) = 489$$

This value for CFDEN should be loaded into each meter before calibration. The WGAIN register can then be used to finely calibrate the CF output. The following sections explain how to calibrate a meter based on ADE7763 when using a reference meter or an accurate source.

Calibrating Watt Gain Using a Reference Meter Example

The CFDEN and CFNUM values for the design should be written to their respective registers before beginning the calibration steps shown in Figure 71. When using a reference meter, the percent error in CF is measured by comparing the CF output of the ADE7763 meter with the pulse output of the reference meter, using the same test conditions for both meters. Equation 41 defines the percent error with respect to the pulse outputs of both meters (using the base current, I_b):

$$\%ERROR_{CF(I_B)} = \frac{CF_{I_B} - CF_{ref(I_B)}}{CF_{ref(I_B)}} \times 100 \quad (41)$$

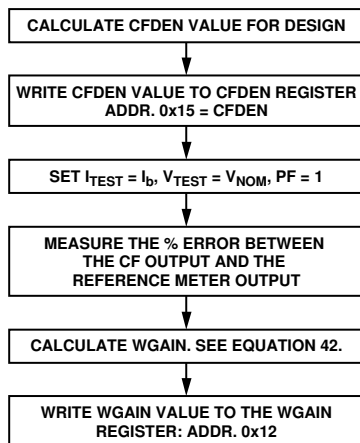

Figure 71. Calibrating Watt Gain Using a Reference Meter

For this example:

- Meter Constant: $MeterConstant(imp/Wh) = 3.2$
- CF Numerator: $CFNUM = 0$
- CF Denominator: $CFDEN = 489$
- %ERROR Measured at Base Current: $\%ERROR_{CF(I_B)} = -3.07\%$

One LSB change in WGAIN changes the active energy registers and CF by 0.0244%. WGAIN is a signed, two's complement register and can correct up to a 50% error. Assuming a -3.07% error, WGAIN is 126:

$$WGAIN = INT\left(\frac{\%ERROR_{CF(I_B)}}{0.0244\%}\right) \quad (42)$$

$$WGAIN = INT\left(\frac{-3.07\%}{0.0244\%}\right) = 126$$

When CF is calibrated, the AENERGY register has the same Wh/LSB constant from meter to meter if the meter constant, WDIV, and the CFNUM/CFDEN ratio remain the same. The Wh/LSB ratio for this meter is 6.378×10^{-4} using Equation 35 with WDIV at the default value.

$$\frac{Wh}{LSB} = \frac{\frac{(CFNUM + 1)}{(CFDEN + 1)} \times WDIV}{MeterConstant(imp/Wh)}$$

$$\frac{Wh}{LSB} = \frac{1}{\frac{(490 + 1)}{3.200 \text{ imp/Wh}}} = \frac{1}{490 \times 3.2} = 6.378 \times 10^{-4}$$

Calibrating Watt Gain Using an Accurate Source Example

The CFDEN value calculated using Equation 40 should be written to the CFDEN register before beginning calibration and zero should be written to the CFNUM register. Enable the line accumulation mode and the line accumulation interrupt. Then, write the number of half line cycles for the energy accumulation to the LINECYC register to set the accumulation time. Reset the interrupt status register and wait for the line cycle accumulation interrupt. The first line cycle accumulation results might not use the accumulation time set by the LINECYC register and, therefore, should be discarded. After resetting the interrupt status register, the following line cycle readings will be valid. When LINECYC half line cycles have elapsed, the \overline{IRQ} pin goes active low and the nominal LAENERGY with the test current applied can be read. This LAENERGY value is compared to the expected LAENERGY value to determine the WGAIN value. If apparent energy gain calibration is performed at the same time, LVAENERGY can be read directly after LAENERGY. Both registers should be read before the next interrupt is issued on the \overline{IRQ} pin. Figure 72 details steps to calibrate the watt gain using an accurate source.

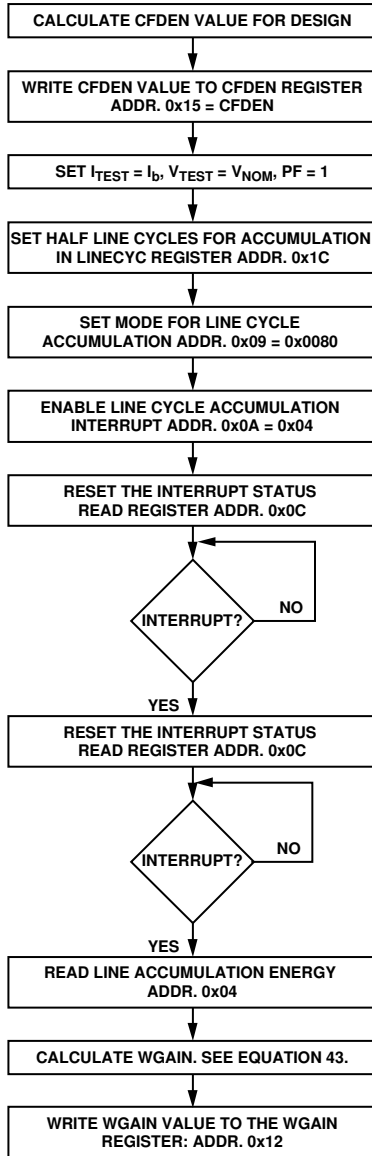

Figure 72. Calibrating Watt Gain Using an Accurate Source

Equation 43 describes the relationship between the expected LAENERGY value and the LAENERGY measured in the test condition:

$$WGAIN = INT \left(\left(\frac{LAENERGY_{IB(expected)}}{LAENERGY_{IB(nominal)}} - 1 \right) \times 2^{12} \right) \quad (43)$$

The nominal LAENERGY reading, $LAENERGY_{IB(nominal)}$, is the LAENERGY reading with the test current applied. The expected LAENERGY reading is calculated from the following equation:

$$LAENERGY_{IB(expected)} = INT \left(\frac{CF_{IB(expected)} \times Accumulation\ Time(s)}{\frac{CFNUM + 1}{CFDEN + 1} \times WDIV} \right) \quad (44)$$

where $CF_{IB(expected)}$ (Hz) is calculated from Equation 30, accumulation time is calculated from Equation 33, and the line period is determined from the period register according to Equation 34.

For this example:

- Meter Constant: $MeterConstant(imp/Wh) = 3.2$
- Test Current: $I_b = 10\ A$
- Line Voltage: $V_{nominal} = 220\ V$
- Line Frequency: $f_i = 50\ Hz$
- Half Line Cycles: $LINECYC_{IB} = 2000$
- CF Numerator: $CFNUM = 0$
- CF Denominator: $CFDEN = 489$
- Energy Reading at Base Current: $LAENERGY_{IB(nominal)} = 17174$

- Period Register Reading: $PERIOD = 8959$
- Clock Frequency: $CLKIN = 3.579545\ MHz$

$CF_{expected}$ is calculated to be 1.9556 Hz according to Equation 30. $LAENERGY_{expected}$ is calculated to be 19186 using Equation 44.

$$CF_{IB(expected)}(Hz) = \frac{3.200\ imp/Wh \times 220\ V \times 10\ A}{3600\ s/h} \times \cos(\phi) = 1.9556\ Hz$$

$$LAENERGY_{IB(expected)} = INT \left(\frac{CF_{IB(expected)} \times LINECYC_{IB} / 2 \times PERIOD \times 8 / CLKIN}{\frac{CFNUM + 1}{CFDEN + 1} \times WDIV} \right)$$

$$LAENERGY_{IB(expected)} = INT \left(\frac{1.9556 \times 2000 / 2 \times 8959 \times 8 / (3.579545 \times 10^6)}{\frac{1}{489 + 1}} \right) = INT(19186.4) = 19186$$

WGAIN is calculated to be 480 using Equation 43.

$$WGAIN = INT\left(\left(\frac{19186}{17174} - 1\right) \times 2^{12}\right) = 480$$

Note that WGAIN is a signed, twos complement register.

With WDIV and CFNUM set to 0, LAENERGY can be expressed as

$$LAENERGY_{IB(expected)} = INT(CF_{IB(expected)} \times LINECYC_{IB} / 2 \times PERIOD \times 8 / CLKIN \times (CFDEN + 1))$$

The calculated Wh/LSB ratio for the active energy register, using Equation 35 is 6.378×10^{-4} is

$$Wh/LSB = \frac{1}{\frac{(489 + 1)}{3.200 \text{ imp/Wh}}} = 6.378 \times 10^{-4}$$

Watt Offset

Offset calibration allows outstanding performance over a wide dynamic range, for example, 1000:1. To do this calibration two measurements are needed at unity power factor, one at I_b and the other at the lowest current to be corrected. Either calibration frequency or line cycle accumulation measurements can be used to determine the energy offset. Gain calibration should be performed prior to offset calibration.

Offset calibration is performed by determining the active energy error rate. After determining the active energy error rate, calculate the value to write to the APOS register to correct the offset.

$$APOS = - \frac{AENERGY \text{ Error Rate} \times 2^{35}}{CLKIN} \tag{45}$$

The AENERGY registers update at a rate of CLKIN/4. The twos complement APOS register provides a fine adjustment to the active power calculation. It represents a fixed amount of power offset to be adjusted every CLKIN/4. The 8 LSBs of the APOS register are fractional such that one LSB of APOS represents 1/256 of the least significant bit of the internal active energy register. Therefore, one LSB of the APOS register represents 2^{-33} of the AENERGY[23:0] active energy register.

See the following sections for steps to determine the active energy error rate for both line accumulation and reference meter calibration options.

Calibrating Watt Offset Using a Reference Meter Example

Figure 73 shows the steps involved in calibrating watt offset with a reference meter.

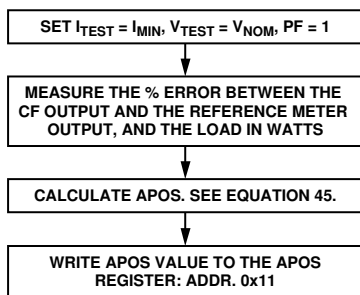

Figure 73. Calibrating Watt Offset Using a Reference Meter

For this example:

Meter Constant:	MeterConstant(imp/Wh) = 3.2
Minimum Current:	$I_{MIN} = 40 \text{ mA}$
Load at Minimum Current:	$W_{IMIN} = 9.6 \text{ W}$
CF Error at Minimum Current:	$\%ERROR_{CF(IMIN)} = 1.3\%$
CF Numerator:	CFNUM = 0
CF Denominator:	CFDEN = 489
Clock Frequency:	CKIN = 3.579545 MHz

Using Equation 45, APOS is -522 for this example.

$$CF \text{ Absolute Error} = CF_{IMIN(nominal)} - CF_{IMIN(expected)} \tag{46}$$

$$CF \text{ Absolute Error} = (\%ERROR_{CF(IMIN)}) \times W_{IMIN} \times \frac{MeterConstant(imp/Wh)}{3600} \tag{47}$$

$$CF \text{ Absolute Error} = \left(\frac{1.3\%}{100}\right) \times 9.6 \times \frac{3.200}{3600} = 0.000110933 \text{ Hz}$$

Then,

$$AENERGY \text{ Error Rate (LSB/s)} = CF \text{ Absolute Error} \times \frac{CFDEN + 1}{CFNUM + 1} \tag{48}$$

$$AENERGY \text{ Error Rate (LSB/s)} = 0.000110933 \times \frac{490}{1} = 0.05436$$

Using Equation 45, APOS is -522.

$$APOS = - \frac{0.05436 \times 2^{35}}{3.579545 \times 10^6} = -522$$

APOS can be represented as follows with CFNUM and WDIV set at 0:

$$APOS = - \frac{(\%ERROR_{CF(IMIN)}) \times W_{IMIN} \times \frac{MeterConstant(imp/Wh)}{3600} \times (CFDEN + 1) \times 2^{35}}{CLKIN}$$

Calibrating Watt Offset with an Accurate Source Example

Figure 74 is the flowchart for watt offset calibration with an accurate source.

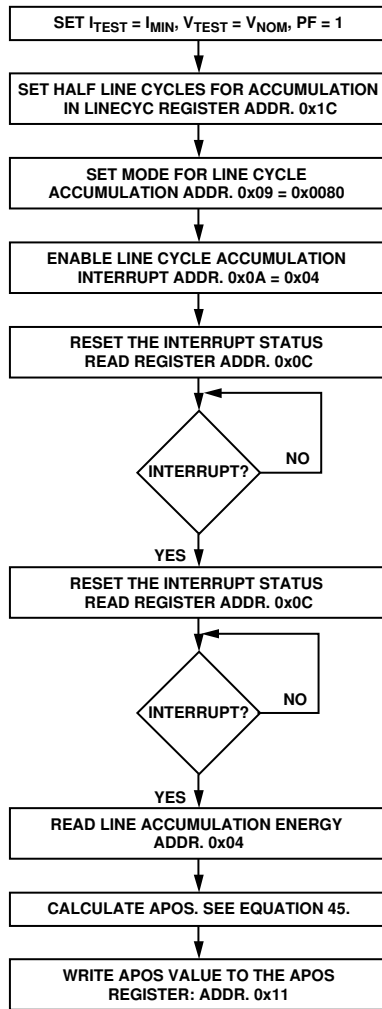

Figure 74. Calibrating Watt Offset with an Accurate Source

For this example:

- Meter Constant: $MeterConstant(imp/Wh) = 3.2$
- Line Voltage: $V_{nominal} = 220 V$
- Line Frequency: $f_l = 50 Hz$
- CF Numerator: $CFNUM = 0$
- CF Denominator: $CFDEN = 489$
- Base Current: $I_b = 10 A$
- Half Line Cycles Used at Base Current: $LINECYC_{IB} = 2000$
- Period Register Reading: $PERIOD = 8959$
- Clock Frequency: $CLKIN = 3.579545 MHz$
- Expected LAENERGY Register Value at Base Current (from the Watt Gain section): $LAENERGY_{IB(expected)} = 19186$
- Minimum Current: $I_{MIN} = 40 mA$

Number of Half Line Cycles used at Minimum Current:

$$LINECYC_{(MIN)} = 35700$$

Active Energy Reading at Minimum Current:

$$LAENERGY_{IMIN(nominal)} = 1395$$

The LAENERGY_{expected} at I_{MIN} is 1255 using Equation 49.

$$LAENERGY_{IMIN(expected)} = INT \left(\frac{I_{MIN}}{I_B} \times LAENERGY_{IB(expected)} \times \frac{LINECYC_{IMIN}}{LINECYC_{IB}} \right) \quad (49)$$

$$LAENERGY_{IMIN(expected)} = INT \left(\frac{0.04}{10} \times 19186 \times \frac{35700}{2000} \right) = INT(1369.80) = 1370$$

where:

LAENERGY_{IB(expected)} is the expected LAENERGY reading at I_b from the watt gain calibration.

LINECYC_{MIN} is the number of half line cycles that energy is accumulated over when measuring at I_{MIN}.

More line cycles could be required at the minimum current to minimize the effect of quantization error on the offset calibration. For example, if a test current of 40 mA results in an active energy accumulation of 113 after 2000 half line cycles, one LSB variation in this reading represents a 0.8% error. This measurement does not provide enough resolution to calibrate a <1% offset error. However, if the active energy is accumulated over 37,500 half line cycles, one LSB variation results in 0.05% error, reducing the quantization error.

APOS is -672 using Equations 55 and 49.

$$LAENERGY \text{ Absolute Error} = LAENERGY_{IMIN(nominal)} - LAENERGY_{IMIN(expected)}$$

$$LAENERGY \text{ Absolute Error} = 1395 - 1370 = 25 \quad (50)$$

$$AENERGY \text{ Error Rate (LSB/s)} = \frac{LAENERGY \text{ Absolute Error}}{LINECYC / 2} \times \frac{CLKIN}{8 \times PERIOD} \quad (51)$$

$$AENERGY \text{ Error Rate (LSB/s)} = \frac{25}{35700 / 2} \times \frac{3.579545 \times 10^6}{8 \times 8959} = 0.069948771$$

$$APOS = - \frac{AENERGY \text{ Error Rate} \times 2^{35}}{CLKIN}$$

$$APOS = - \frac{0.069948771 \times 2^{35}}{3.579545 \times 10^6} = -672$$

Phase Calibration

The PHCAL register is provided to remove small phase errors. The ADE7763 compensates for phase error by inserting a small time delay or advance on the voltage channel input. Phase leads up to 1.84° and phase lags up to 0.72° at 50 Hz can be corrected. The error is determined by measuring the active energy at I_B and two power factors, PF = 1 and PF = 0.5 inductive.

Some CTs may introduce large phase errors that are beyond the range of the phase calibration register. In this case, coarse phase compensation has to be done externally with an analog filter.

The phase error can be obtained from either CF or LAENERGY measurements:

$$Error = \frac{LAENERGY_{IB, PF = 0.5} - LAENERGY_{IB(expected)} / 2}{LAENERGY_{IB(expected)} / 2} \quad (52)$$

If watt gain and offset calibration have been performed, there should be 0% error in CF at unity power factor, and then

$$Error = \%ERROR_{CF(IB, PF = 0.5)} / 100 \quad (53)$$

The phase error is

$$Phase\ Error\ (^{\circ}) = -\text{Arcsin}\left(\frac{Error}{\sqrt{3}}\right) \quad (54)$$

The relationship between phase error and the PHCAL phase correction register is

$$PHCAL = INT\left(Phase\ Error(^{\circ}) \times \frac{PERIOD}{360^{\circ}}\right) + 0x0D \quad (55)$$

The expression for PHCAL can be simplified using the assumption that at small x

$$\text{Arcsin}(x) \approx x$$

The delay introduced in the voltage channel by PHCAL is

$$Delay = (PHCAL - 0x0D) \times 8 / CLKIN \quad (56)$$

The delay associated with the PHCAL register is a time delay if PHCAL - 0x0D is positive, but represents a time advance if this quantity is negative. There is no time delay if PHCAL = 0x0D.

The phase correction is in the opposite direction of the phase error.

$$Phase\ Correction\ (^{\circ}) = - (PHCAL - 0x0D) \times \frac{360^{\circ}}{PERIOD} \quad (57)$$

Calibrating Phase Using a Reference Meter Example

A power factor of 0.5 inductive can be assumed if the pulse output rate of the reference meter is half of its PF = 1 rate. Then, the percent error between CF and the pulse output of the reference meter can be used to perform the preceding calculations.

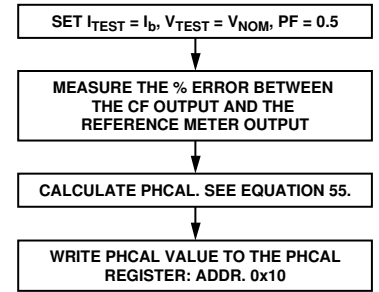

Figure 75. Calibrating Phase Using a Reference Meter

For this example:

CF %ERROR at PF = 0.5 Inductive: %ERROR_{CF(IB, PF = 0.5)} = 0.215%
 PERIOD Register Reading: PERIOD = 8959

Then PHCAL is 11 using Equations 57 through 59:

$$Error = 0.215\% / 100 = 0.00215$$

$$Phase\ Error\ (^{\circ}) = -\text{Arcsin}\left(\frac{0.00215}{\sqrt{3}}\right) = -0.07^{\circ}$$

$$PHCAL = INT\left(-0.07^{\circ} \times \frac{8959}{360^{\circ}}\right) + 0x0D = -2 + 13 = 11$$

PHCAL can be expressed as follows:

$$PHCAL = INT\left(-\text{Arcsin}\left(\frac{\%ERROR \times 100}{\sqrt{3}}\right) \times \frac{PERIOD}{2\pi}\right) + 0x0D \quad (58)$$

Note that PHCAL is a signed, twos complement register.

Setting the PHCAL register to 11 provides a phase correction of 0.08° to correct the phase lead:

$$Phase\ Correction\ (^{\circ}) = - (PHCAL - 0x0D) \times \frac{360^{\circ}}{PERIOD}$$

$$Phase\ Correction\ (^{\circ}) = - (11 - 0x0D) \times \frac{360^{\circ}}{8960} = 0.08^{\circ}$$

Calibrating Phase with an Accurate Source Example

With an accurate source, line cycle accumulation is a good method of calibrating phase error. The value of LAENERGY must be obtained at two power factors, PF = 1 and PF = 0.5 inductive.

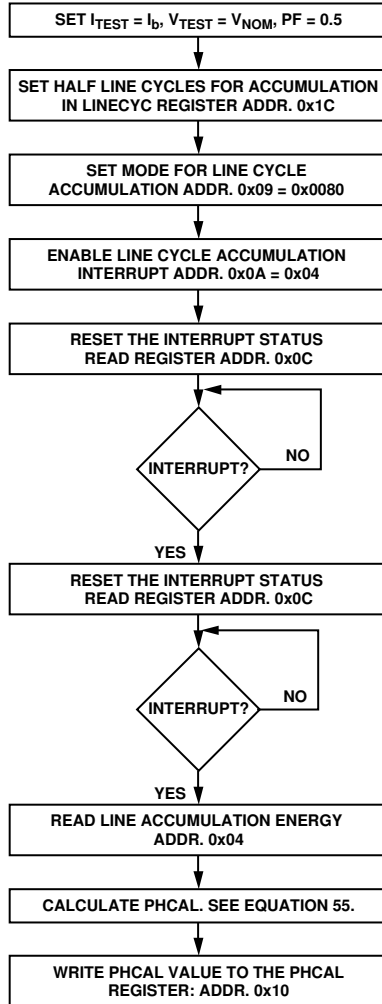

Figure 76. Calibrating Phase with an Accurate Source

For this example:

- Meter Constant: $MeterConstant(imp/Wh) = 3.2$
- Line Voltage: $V_{nominal} = 220\text{ V}$
- Line Frequency: $f_L = 50\text{ Hz}$
- CF Numerator: $CFNUM = 0$
- CF Denominator: $CFDEN = 489$
- Base Current: $I_b = 10\text{ A}$
- Half Line Cycles Used at Base Current: $LINECYC_{IB} = 2000$
- PERIOD Register: $PERIOD = 8959$
- Expected Line Accumulation at Unity Power Factor (from Watt Gain section): $LAENERGY_{IB(expected)} = 19186$
- Active Energy Reading at PF = 0.5 inductive: $LAENERGY_{IB, PF=0.5} = 9613$

The error using Equation 52 is

$$Error = \frac{9613 - 19186}{19186} \times \frac{1}{2} = 0.0021$$

$$Phase\ Error\ (^\circ) = -\text{Arcsin}\left(\frac{0.0021}{\sqrt{3}}\right) = -0.07^\circ$$

Using Equation 55, PHCAL is 11.

$$PHCAL = INT\left(-0.07^\circ \times \frac{8959}{360^\circ}\right) + 0x0D = -2 + 13 = 11$$

Note that PHCAL is a signed, twos complement register.

The phase lead is corrected by 0.08 degrees when the PHCAL register is set to 11:

$$Phase\ Correction\ (^\circ) = -(PHCAL - 0x0D) \times \frac{360^\circ}{PERIOD}$$

$$Phase\ Correction\ (^\circ) = -(11 - 0x0D) \times \frac{360^\circ}{8960} = 0.08^\circ$$

VRMS and IRMS Calibration

VRMS and IRMS are calculated by squaring the input in a digital multiplier.

$$v^2(t) = \sqrt{2} V \sin(\omega t) \times \sqrt{2} V \sin(\omega t) = V^2 - V^2 \times \cos(2\omega t) \tag{59}$$

The square of the rms value is extracted from $v^2(t)$ by a low-pass filter. The square root of the output of this low-pass filter gives the rms value. An offset correction is provided to cancel noise and offset contributions from the input.

There is ripple noise from the 2ω term because the low-pass filter does not completely attenuate the signal. This noise can be minimized by synchronizing the rms register readings with the zero crossing of the voltage signal. The IRQ output can be configured to indicate the zero crossing of the voltage signal.

This flowchart demonstrates how VRMS and IRMS readings are synchronized to the zero crossings of the voltage input.

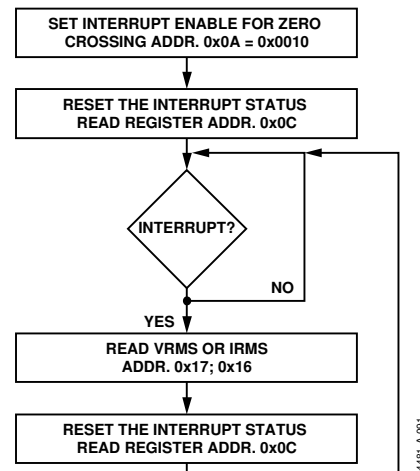

Figure 77. Synchronizing VRMS and IRMS Readings with Zero Crossings

Voltage rms compensation is done after the square root.

$$VRMS = VRMS0 + VRMSOS \quad (60)$$

where:

$VRMS0$ is the rms measurement without offset correction.
 $VRMS$ is linear from full-scale to full-scale/20.

To calibrate the offset, two $VRMS$ measurements are required, for example, at $V_{nominal}$ and $V_{nominal}/10$. $V_{nominal}$ is set at half of the full-scale analog input range so that the smallest linear $VRMS$ reading is at $V_{nominal}/10$.

$$VRMSOS = \frac{V_1 \times VRMS_2 - V_2 \times VRMS_1}{V_2 - V_1} \quad (61)$$

where $VRMS_1$ and $VRMS_2$ are rms register values without offset correction for input V_1 and V_2 , respectively.

If the range of the 12-bit, twos complement $VRMSOS$ register is not enough, use the voltage channel offset register, $CH2OS$, to correct the $VRMS$ offset.

Current rms compensation is performed before the square root:

$$IRMS^2 = IRMS0^2 + 32768 \times IRMSOS \quad (62)$$

where $IRMS0$ is the rms measurement without offset correction. The current rms calculation is linear from full scale to full scale/100.

To calibrate this offset, two $IRMS$ measurements are required, for example, at I_b and $I_{MAX}/50$. I_{MAX} is set at half of the full-scale analog input range so that the smallest linear $IRMS$ reading is at $I_{MAX}/50$.

$$IRMSOS = \frac{1}{32768} \times \frac{I_1^2 \times IRMS_2^2 - I_2^2 \times IRMS_1^2}{I_2^2 - I_1^2} \quad (63)$$

where $IRMS_1$ and $IRMS_2$ are rms register values without offset correction for input I_1 and I_2 , respectively.

Apparent Energy

Apparent energy gain calibration is provided for both meter-to-meter gain adjustment and for setting the VAh/LSB constant.

$VAENERGY =$

$$VAENERGY_{initial} \times \frac{1}{VADIV} \times \left(1 + \frac{VAGAIN}{2^{12}} \right) \quad (64)$$

$VADIV$ is similar to the $CFDEN$ for the watt-hour calibration. It should be the same across all meters and determines the VAh/LSB constant. $VAGAIN$ is used to calibrate individual meters.

Apparent energy gain calibration should be performed before rms offset correction to make the most efficient use of the current test points. Apparent energy gain and watt gain compensation require testing at I_b , while rms and watt offset correction require a lower test current. Apparent energy gain calibration can be done simultaneously with the watt-hour gain calibration using line cycle accumulation. In this case, $LAENERGY$ and $LVAENERGY$, the line cycle accumulation apparent energy registers, are both read following the line cycle accumulation interrupt. Figure 78 shows a flowchart for calibrating active and apparent energy simultaneously.

$$VAGAIN = INT \left(\left(\frac{LVAENERGY_{IB(expected)}}{LVAENERGY_{IB(nominal)}} - 1 \right) \times 2^{12} \right) \quad (65)$$

$LVAENERGY_{IB(expected)} =$

$$INT \left(\frac{V_{nominal} \times I_B}{\frac{VAh}{LSB} constant \times 3600 \text{ s/h}} \times Accumulation \text{ time}(s) \right) \quad (66)$$

The accumulation time is determined from Equation 33, and the line period can be determined from the period register according to Equation 34. The VAh represented by the $VAENERGY$ register is

$$VAh = VAENERGY \times VAh/LSB \text{ constant} \quad (67)$$

The VAh/LSB constant can be verified using this equation:

$$VAh/LSB \text{ constant} = \frac{VA \times Accumulation \text{ time}(s) / 3600}{LVAENERGY} \quad (68)$$

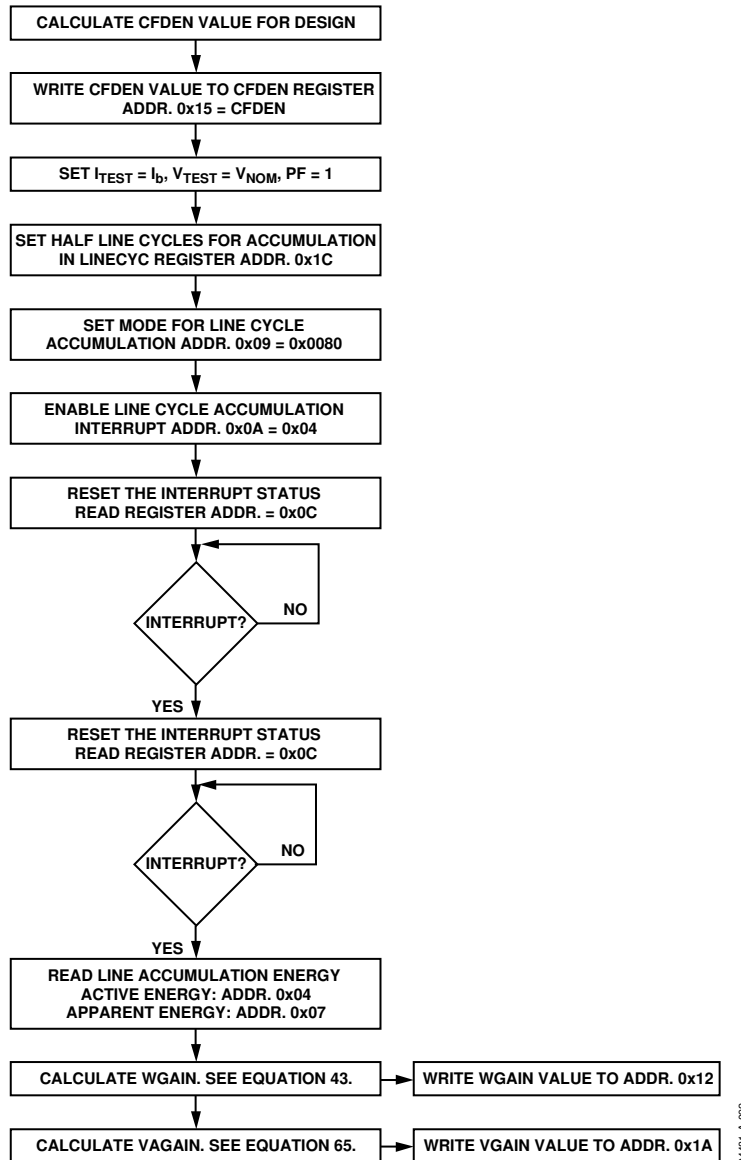

Figure 78. Active/Apparent Gain Calibration

CLKIN FREQUENCY

In this data sheet, the characteristics of the ADE7763 are shown when CLKIN frequency equals 3.579545 MHz. However, the ADE7763 is designed to have the same accuracy at any CLKIN frequency within the specified range. If the CLKIN frequency is not 3.579545 MHz, various timing and filter characteristics will need to be redefined with the new CLKIN frequency. For example, the cutoff frequencies of all digital filters, such as LPF1, LPF2, or HPF1, shift in proportion to the change in CLKIN frequency according to the following equation:

$$New\ Frequency = Original\ Frequency \times \frac{CLKIN\ Frequency}{3.579545\ MHz} \quad (69)$$

The change in CLKIN frequency does not affect the timing characteristics of the serial interface because the data transfer is synchronized with the serial clock signal (SCLK). However, it is important to observe the read/write timing of the serial data

transfer—see the timing characteristics in Table 2. Table 8 lists various timing changes that are affected by CLKIN frequency.

Table 8. Frequency Dependencies of the ADE7763 Parameters

Parameter	CLKIN Dependency
Nyquist Frequency for CH 1, CH 2 ADCs	CLKIN/8
PHCAL Resolution (seconds per LSB)	4/CLKIN
Active Energy Register Update Rate (Hz)	CLKIN/4
Waveform Sampling Rate (per second)	
WAVSEL 1,0 = 00	CLKIN/128
01	CLKIN/256
10	CLKIN/512
11	CLKIN/1024
Maximum ZXTOUT Period	524,288/CLKIN

SUSPENDING FUNCTIONALITY

The analog and the digital circuit can be suspended separately. The analog portion can be suspended by setting the ASUSPEND bit (Bit 4) of the mode register to logic high—see the Mode Register (0x09) section. In suspend mode, all waveform samples from the ADCs are set to 0s. The digital circuitry can be halted by stopping the CLKIN input and maintaining a logic high or low on the CLKIN pin. The ADE7763 can be reactivated by restoring the CLKIN input and setting the ASUSPEND bit to logic low.

CHECKSUM REGISTER

The ADE7763 has a checksum register (CHECKSUM[5:0]) to ensure that the data bits received in the last serial read operation are not corrupted. The 6-bit checksum register is reset before the first bit (MSB of the register to be read) is put on the DOUT pin. During a serial read operation, when each data bit becomes available upon the rising edge of SCLK, the bit is added to the checksum register. At the end of the serial read operation, the content of the checksum register is equal to the sum of all ones previously read in the register. Using the checksum register, the user can determine if an error has occurred during the last read operation. Note that a read to the checksum register also generates a checksum of the checksum register itself.

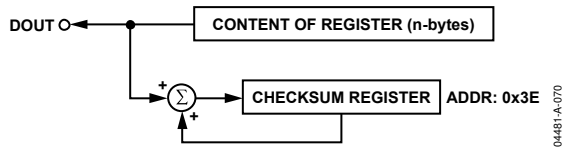

Figure 79. Checksum Register for Serial Interface Read

SERIAL INTERFACE

All ADE7763 functionality is accessible via several on-chip registers—see Figure 80. The contents of these registers can be updated or read using the on-chip serial interface. After power-on or toggling the RESET pin low and a falling edge on CS, the ADE7763 is placed in communication mode. In communication mode, the ADE7763 expects a write to its communication register. The data written to the communication register determines whether the next data transfer operation is a read or a write and which register is accessed. Therefore, all data transfer operations with the ADE7763, whether a read or a write, must begin with a write to the communication register.

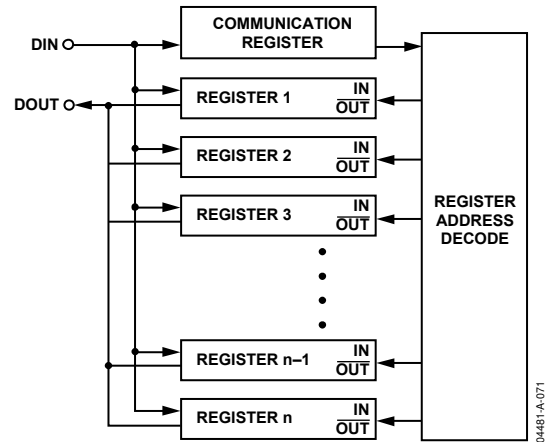

Figure 80. Addressing ADE7763 Registers via the Communication Register

The communication register is an 8-bit-wide register. The MSB determines whether the next data transfer operation is a read or a write. The 6 LSBs contain the address of the register to be accessed—see the Communication Register section for a more detailed description.

Figure 81 and Figure 82 show the data transfer sequences for a read and write operation, respectively. A data transfer is complete when the LSB of the ADE7763 register being addressed (for a write or a read) is transferred to or from the ADE7763. When multiple reads or writes occur in succession, a time delay of 2600 ns must be included between the last falling SCLK edge on the first read or write to the first SCLK falling edge of the next read or write. During that delay time, the CS pin must be high for at least 100 ns.

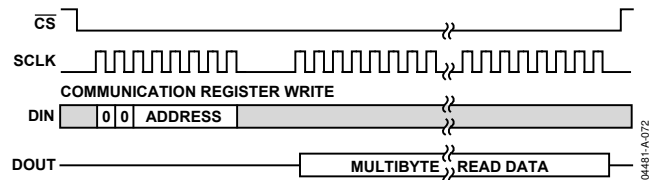

Figure 81. Reading Data from the ADE7763 via the Serial Interface

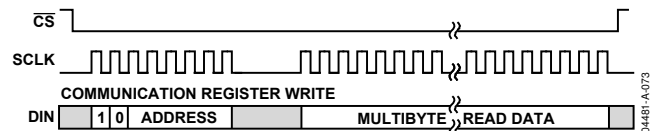

Figure 82. Writing Data to the ADE7763 via the Serial Interface

The serial interface of the ADE7763 is made up of four signals: SCLK, DIN, DOUT, and \overline{CS} . The serial clock for a data transfer is applied at the SCLK logic input. This logic input has a Schmitt-trigger input structure that allows slow rising and falling clock edges to be used. All data transfer operations are synchronized to the serial clock. Data is shifted into the ADE7763 at the DIN logic input upon the falling edge of SCLK. Data is shifted out of the ADE7763 at the DOUT logic output upon a rising edge of SCLK. The \overline{CS} logic input is the chip-select input. This input is used when multiple devices share the serial bus. A falling edge upon \overline{CS} also resets the serial interface and places the ADE7763 into communication mode. The \overline{CS} input should be driven low for the entire data transfer operation. Bringing \overline{CS} high during a data transfer operation aborts the transfer and places the serial bus in a high impedance state. The \overline{CS} logic input can be tied low if the ADE7763 is the only device on the serial bus. However, with \overline{CS} tied low, all initiated data transfer operations must be fully completed, i.e., the LSB of each register must be transferred because there is no other way to bring the ADE7763 into communication mode without resetting the entire device using \overline{RESET} .

ADE7763 Serial Write Operation

The serial write sequence takes place as follows. With the ADE7763 in communication mode (i.e., the \overline{CS} input logic low), first a write to the communication register occurs. The MSB of this byte transfer is a 1, indicating that the data transfer operation is a write. The LSBs of this byte contain the address of

the register to be written to. The ADE7763 starts shifting in the register data upon the next falling edge of SCLK. All remaining bits of register data are shifted in upon the falling edge of subsequent SCLK pulses—see Figure 83. As explained earlier, the data write is initiated by a write to the communication register followed by the data. During a data write operation, data is transferred to all on-chip registers one byte at a time. After a byte is transferred into the serial port, there is a finite time before it is transferred to one of the ADE7763 on-chip registers. Although another byte transfer to the serial port can start while the previous byte is being transferred to an on-chip register, this second byte transfer should not finish until at least 4 μ s after the end of the previous byte transfer. This functionality is expressed in the timing specification t_6 —see Figure 83. If a write operation is aborted during a byte transfer (\overline{CS} is brought high), then that byte cannot be written to the destination register.

Destination registers can be up to 3 bytes wide—see Table 9, Table 10, Table 11, Table 12, and Table 13. Therefore the first byte shifted into the serial port at DIN is transferred to the MSB (most significant byte) of the destination register. If, for example, the addressed register is 12 bits wide, a 2-byte data transfer must take place. Because the data is always assumed to be right justified, in this case the 4 MSBs of the first byte would be ignored and the 4 LSBs of the first byte written to the ADE7763 would be the 4 MSBs of the 12-bit word. Figure 84 illustrates this example.

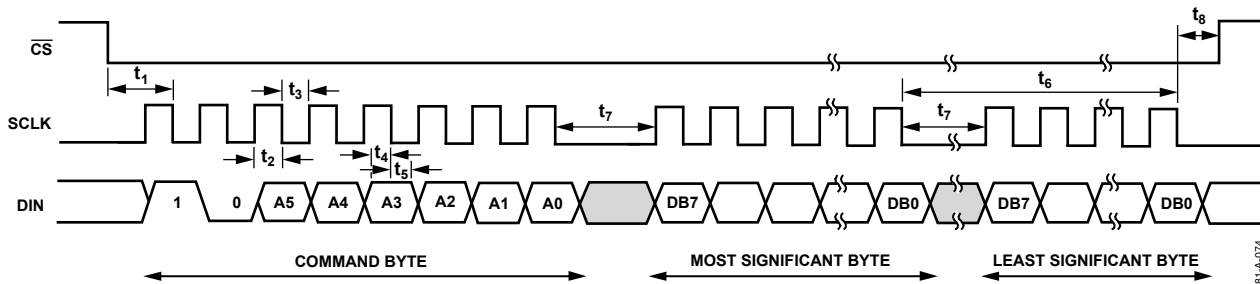

Figure 83. Serial Interface Write Timing

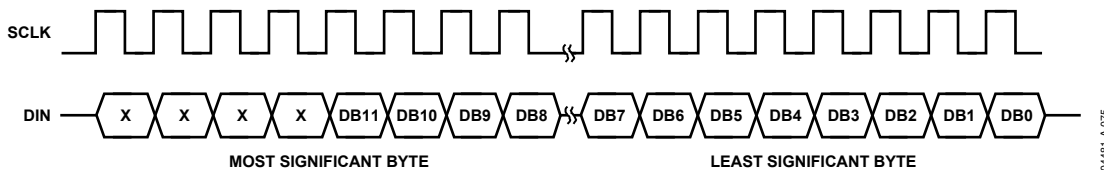

Figure 84. 12-Bit Serial Write Operation

Serial Read Operation

During a data read operation from the ADE7763, data is shifted out at the DOUT logic output upon the rising edge of SCLK. As is the case with the data write operation, a write to the communication register must precede a data read.

With the ADE7763 in communication mode (\overline{CS} logic low), first an 8-bit write to the communication register occurs. The MSB of this byte transfer is a 0, indicating that the next data transfer operation is a read. The LSBs of this byte contain the address of the register that is to be read. The ADE7763 starts shifting data out of the register upon the next rising edge of SCLK—see Figure 85. At this point, the DOUT logic output leaves its high impedance state and starts driving the data bus. All remaining bits of register data are shifted out upon subsequent SCLK rising edges. The serial interface also enters communication mode as soon as the read is complete. Then, the DOUT

logic output enters a high impedance state upon the falling edge of the last SCLK pulse. The read operation can be aborted by bringing the \overline{CS} logic input high before the data transfer is complete. The DOUT output enters a high impedance state upon the rising edge of \overline{CS} .

When an ADE7763 register is addressed for a read operation, the entire contents of that register are transferred to the serial port. This allows the ADE7763 to modify its on-chip registers without the risk of corrupting data during a multibyte transfer.

Note that when a read operation follows a write operation, the read command (i.e., write to communication register) should not happen for at least 4 μs after the end of the write operation. If the read command is sent within 4 μs of the write operation, the last byte of the write operation could be lost. This timing constraint is given as timing specification t_9 .

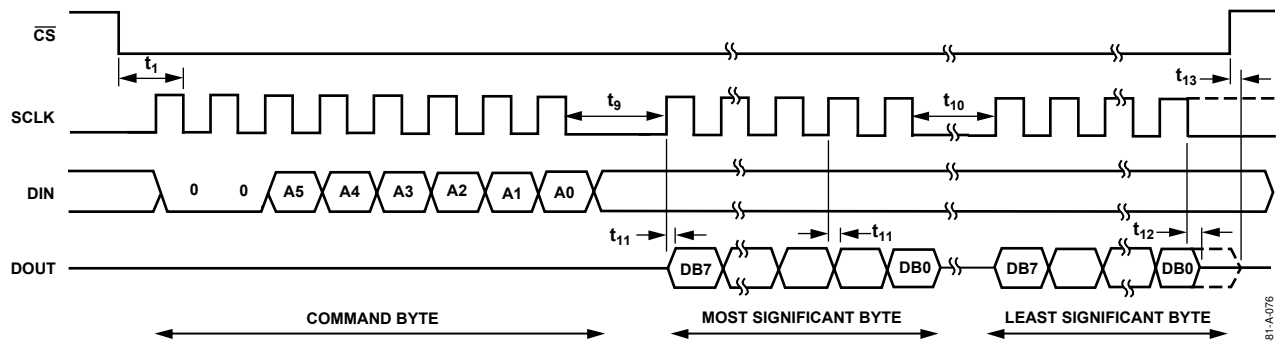

Figure 85. Serial Interface Read Timing

04481-A-07/6

REGISTERS

Table 9. Summary of Registers by Address

Address	Name	R/W	No. Bits	Default	Type ¹	Description
0x01	WAVEFORM	R	24	0x0	S	Waveform Register. When WSMP (Bit 3) in the interrupt enable register is set to 1, this read-only register contains the sampled waveform data from either Channel 1, Channel 2, or the active power signal. The data source and the length of the waveform registers are selected by Bits 14 and 13 in the mode register—see the Channel 1 Sampling and Channel 2 Sampling sections.
0x02	AENERGY	R	24	0x0	S	Active Energy Register. Active power is accumulated (integrated) over time in this 24-bit, read-only register—see the Energy Calculation section.
0x03	RAENERGY	R	24	0x0	S	Same as the active energy register, except that the register is reset to 0 following a read operation.
0x04	LAENERGY	R	24	0x0	S	Line Accumulation Active Energy Register. The instantaneous active power is accumulated in this read-only register over the LINECYC number of half line cycles.
0x05	VAENERGY	R	24	0x0	U	Apparent Energy Register. Apparent power is accumulated over time in this read-only register.
0x06	RVAENERGY	R	24	0x0	U	Same as the VAENERGY register, except that the register is reset to 0 following a read operation.
0x07	LVAENERGY	R	24	0x0	U	Line Accumulation Apparent Energy Register. The instantaneous real power is accumulated in this read-only register over the LINECYC number of half line cycles.
0x08 0x09	RESERVED MODE	R/W	16	0x000C	U	Mode Register. This is a 16-bit register through which most of the ADE7763's functionality is accessed. Signal sample rates, filter enabling, and calibration modes are selected by writing to this register. The contents can be read at any time—see the Mode Register (0X09) section.
0x0A	IRQEN	R/W	16	0x40	U	Interrupt Enable Register. ADE7763 interrupts can be deactivated at any time by setting the corresponding bit in this 16-bit enable register to Logic 0. The status register continues to detect an interrupt event even if disabled; however, the IRQ output is not activated—see the Interrupts section.
0x0B	STATUS	R	16	0x0	U	Interrupt Status Register. This is a 16-bit read-only register that contains information regarding the source of ADE7763 interrupts—see the Interrupts section.
0x0C	RSTSTATUS	R	16	0x0	U	Same as the interrupt status register, except that the register contents are reset to 0 (all flags cleared) after a read operation.
0x0D	CH1OS	R/W	8	0x00	S*	Channel 1 Offset Adjust. Bit 6 is not used. Writing to Bits 0 to 5 allows offsets on Channel 1 to be removed—see the Analog Inputs and CH1OS Register sections. Writing Logic 1 to the MSB of this register enables the digital integrator on Channel 1; writing Logic 0 disables the integrator. The default value of this bit is 0.
0x0E	CH2OS	R/W	8	0x0	S*	Channel 2 Offset Adjust. Bits 6 and 7 are not used. Writing to Bits 0 to 5 of this register allows offsets on Channel 2 to be removed—see the Analog Inputs section. Note that the CH2OS register is inverted. To apply a positive offset, a negative number is written to this register.
0x0F	GAIN	R/W	8	0x0	U	PGA Gain Adjust. This 8-bit register is used to adjust the gain selection for the PGA in Channels 1 and 2—see the Analog Inputs section.
0x10	PHCAL	R/W	6	0x0D	S	Phase Calibration Register. The phase relationship between Channel 1 and 2 can be adjusted by writing to this 6-bit register. The valid content of this two's complement register is between 0x1D to 0x21. At the line frequency of 60 Hz, this ranges from -2.06° to $+0.7^\circ$ —see the Phase Compensation section.

Address	Name	R/W	No. Bits	Default	Type ¹	Description
0x11	APOS	R/W	16	0x0	S	Active Power Offset Correction. This 16-bit register allows small offsets in the active power calculation to be removed—see the Active Power Calculation section.
0x12	WGAIN	R/W	12	0x0	S	Power Gain Adjust. This is a 12-bit register. Calibrate the active power calculation by writing to this register. The calibration range is $\pm 50\%$ of the nominal full-scale active power. The resolution of the gain adjust is 0.0244%/LSB—see the Calibrating an Energy Meter section.
0x13	WDIV	R/W	8	0x0	U	Active Energy Divider Register. The internal active energy register is divided by the value of this register before being stored in the AENERGY register.
0x14	CFNUM	R/W	12	0x3F	U	CF Frequency Divider Numerator Register. Adjust the output frequency on the CF pin by writing to this 12-bit read/write register—see the Energy-to-Frequency Conversion section.
0x15	CFDEN	R/W	12	0x3F	U	CF Frequency Divider Denominator Register. Adjust the output frequency on the CF pin by writing to this 12-bit read/write register—see the Energy-to-Frequency Conversion section.
0x16	IRMS	R	24	0x0	U	Channel 1 RMS Value (Current Channel).
0x17	VRMS	R	24	0x0	U	Channel 2 RMS Value (Voltage Channel).
0x18	IRMSOS	R/W	12	0x0	S	Channel 1 RMS Offset Correction Register. Note that for correct operation only positive values should be written to the IRMSOS register.
0x19	VRMSOS	R/W	12	0x0	S	Channel 2 RMS Offset Correction Register.
0x1A	VAGAIN	R/W	12	0x0	S	Apparent Gain Register. Calibrate the apparent power calculation by writing to this register. The calibration range is 50% of the nominal full-scale real power. The resolution of the gain adjust is 0.02444%/LSB.
0x1B	VADIV	R/W	8	0x0	U	Apparent Energy Divider Register. The internal apparent energy register is divided by the value of this register before being stored in the VAENERGY register.
0x1C	LINECYC	R/W	16	0xFFFF	U	Line Cycle Energy Accumulation Mode Line-Cycle Register. This 16-bit register is used during line cycle energy accumulation mode to set the number of half line cycles for energy accumulation—see the Line Cycle Energy Accumulation Mode section.
0x1D	ZXTOUT	R/W	12	0xFFF	U	Zero-Crossing Timeout. If no zero crossings are detected on Channel 2 within the time specified in this 12-bit register, the interrupt request line (\overline{IRQ}) will be activated—see the Zero-Crossing Detection section.
0x1E	SAGCYC	R/W	8	0xFF	U	Sag Line Cycle Register. This 8-bit register specifies the number of consecutive line cycles below SAGLVL that is required on Channel 2 before the SAG output is activated—see the Line Voltage Sag Detection section.
0x1F	SAGLVL	R/W	8	0x0	U	Sag Voltage Level. An 8-bit write to this register determines at what peak signal level on Channel 2 the \overline{SAG} pin becomes active. The signal must remain low for the number of cycles specified in the SAGCYC register before the \overline{SAG} pin is activated—see the Line Voltage Sag Detection section.
0x20	IPKLVL	R/W	8	0xFF	U	Channel 1 Peak Level Threshold (Current Channel). This register sets the level of current peak detection. If the Channel 1 input exceeds this level, the PKI flag in the status register is set.
0x21	VPKLVL	R/W	8	0xFF	U	Channel 2 Peak Level Threshold (Voltage Channel). This register sets the level of voltage peak detection. If the Channel 2 input exceeds this level, the PKV flag in the status register is set.
0x22	IPEAK	R	24	0x0	U	Channel 1 Peak Register. The maximum input value of the current channel, since the last read of the register is stored in this register.
0x23	RSTIPEAK	R	24	0x0	U	Same as Channel 1 peak register, except that the register contents are reset to 0 after a read.
0x24	VPEAK	R	24	0x0	U	Channel 2 Peak Register. The maximum input value of the voltage channel, since the last read of the register is stored in this register.
0x25	RSTVPEAK	R	24	0x0	U	Same as Channel 2 peak register, except that the register contents are reset to 0 after a read.

Address	Name	R/W	No. Bits	Default	Type ¹	Description
0x26	TEMP	R	8	0x0	S	Temperature Register. This is an 8-bit register that contains the result of the latest temperature conversion—see the Temperature Measurement section.
0x27	PERIOD	R	16	0x0	U	Period of the Channel 2 (Voltage Channel) Input Estimated by Zero-Crossing Processing. The MSB of this register is always zero.
0x28– 0x3C						Reserved.
0x3D	TMODE	R/W	8	–	U	Test Mode Register.
0x3E	CHKSUM	R	6	0x0	U	Checksum Register. This 6-bit, read-only register is equal to the sum of all the ones in the previous reads—see the Serial Read Operation section.
0x3F	DIEREV	R	8	–	U	Die Revision Register. This 8-bit, read-only register contains the revision number of the silicon.

¹ Type decoder: U = unsigned, S = signed by twos complement method, and S' = signed by sign magnitude method.

REGISTER DESCRIPTIONS

All ADE7763 functionality is accessed via on-chip registers. Each register is accessed by first writing to the communication register and then transferring the register data. A full description of the serial interface protocol is given in the Serial Interface section.

COMMUNICATION REGISTER

The communication register is an 8-bit, write-only register that controls the serial data transfer between the ADE7763 and the host processor. All data transfer operations must begin with a write to the communication register. The data written to the communication register determines whether the next operation is a read or a write and which register is being accessed. Table 10 outlines the bit designations for the communication register.

DB7	DB6	DB5	DB4	DB3	DB2	DB1	DB0
W/R	0	A5	A4	A3	A2	A1	A0

Table 10. Communication Register

Bit Location	Bit Mnemonic	Description
0 to 5	A0 to A5	The 6 LSBs of the communication register specify the register for the data transfer operation. Table 9 lists the address of each on-chip register.
6	RESERVED	This bit is unused and should be set to 0.
7	W/R	When this bit is a Logic 1, the data transfer operation immediately following the write to the communication register is interpreted as a write to the ADE7763. When this bit is a Logic 0, the data transfer operation immediately following the write to the communication register is interpreted as a read operation.

MODE REGISTER (0x09)

The ADE7763 functionality is configured by writing to the mode register. Table 11 describes the functionality of each bit in the register.

Table 11.

Bit Location	Bit Mnemonic	Default Value	Description															
0	DISHPF	0	HPF (high-pass filter) in Channel 1 is disabled when this bit is set.															
1	DISLPF2	0	LPF (low-pass filter) after the multiplier (LPF2) is disabled when this bit is set.															
2	DISCF	1	Frequency output CF is disabled when this bit is set.															
3	DISSAG	1	Line voltage sag detection is disabled when this bit is set.															
4	ASUSPEND	0	By setting this bit to Logic 1, both A/D converters can be turned off. During normal operation, this bit should be left at Logic 0. All digital functionality can be stopped by suspending the clock signal at CLKIN pin.															
5	TEMPSEL	0	Temperature conversion starts when this bit is set to 1. This bit is automatically reset to 0 after the temperature conversion.															
6	SWRST	0	Software Chip Reset. A data transfer should not take place to the ADE7763 for at least 18 μ s after a software reset.															
7	CYCMODE	0	Setting this bit to Logic 1 places the chip in line cycle energy accumulation mode.															
8	DISCH1	0	ADC 1 (Channel 1) inputs are internally shorted together.															
9	DISCH2	0	ADC 2 (Channel 2) inputs are internally shorted together.															
10	SWAP	0	By setting this bit to Logic 1, the analog inputs V2P and V2N are connected to ADC 1 and the analog inputs V1P and V1N are connected to ADC 2.															
12, 11	DTRT1, 0	00	Use these bits to select the waveform register update rate. <table border="1" style="margin-left: 20px;"> <thead> <tr> <th>DTRT1</th> <th>DTRT0</th> <th>Update Rate</th> </tr> </thead> <tbody> <tr> <td>0</td> <td>0</td> <td>27.9 kSPS (CLKIN/128)</td> </tr> <tr> <td>0</td> <td>1</td> <td>14 kSPS (CLKIN/256)</td> </tr> <tr> <td>1</td> <td>0</td> <td>7 kSPS (CLKIN/512)</td> </tr> <tr> <td>1</td> <td>1</td> <td>3.5 kSPS (CLKIN/1024)</td> </tr> </tbody> </table>	DTRT1	DTRT0	Update Rate	0	0	27.9 kSPS (CLKIN/128)	0	1	14 kSPS (CLKIN/256)	1	0	7 kSPS (CLKIN/512)	1	1	3.5 kSPS (CLKIN/1024)
DTRT1	DTRT0	Update Rate																
0	0	27.9 kSPS (CLKIN/128)																
0	1	14 kSPS (CLKIN/256)																
1	0	7 kSPS (CLKIN/512)																
1	1	3.5 kSPS (CLKIN/1024)																

Bit Location	Bit Mnemonic	Default Value	Description															
14, 13	WAVSEL1, 0	00	Use these bits to select the source of the sampled data for the waveform register. <table border="1"> <thead> <tr> <th>WAVSEL1, 0</th> <th>Length</th> <th>Source</th> </tr> </thead> <tbody> <tr> <td>0</td> <td>0</td> <td>24 bits, active power signal (output of LPF2)</td> </tr> <tr> <td>0</td> <td>1</td> <td>Reserved</td> </tr> <tr> <td>1</td> <td>0</td> <td>24 bits, Channel 1</td> </tr> <tr> <td>1</td> <td>1</td> <td>24 bits, Channel 2</td> </tr> </tbody> </table>	WAVSEL1, 0	Length	Source	0	0	24 bits, active power signal (output of LPF2)	0	1	Reserved	1	0	24 bits, Channel 1	1	1	24 bits, Channel 2
WAVSEL1, 0	Length	Source																
0	0	24 bits, active power signal (output of LPF2)																
0	1	Reserved																
1	0	24 bits, Channel 1																
1	1	24 bits, Channel 2																
15	POAM	0	Writing Logic 1 to this bit allows only positive active power to accumulate. The default value of this bit is 0.															

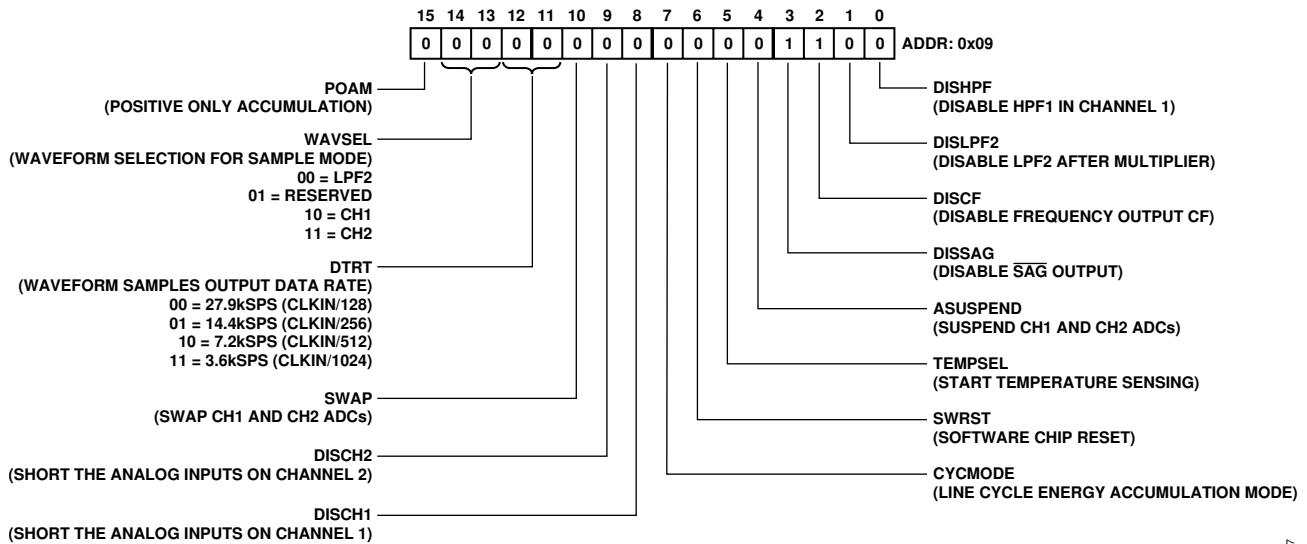

NOTE: REGISTER CONTENTS SHOW POWER-ON DEFAULTS

Figure 86. Mode Register

04481-A-077

**INTERRUPT STATUS REGISTER (0x0B),
RESET INTERRUPT STATUS REGISTER (0x0C),
INTERRUPT ENABLE REGISTER (0x0A)**

The status register is used by the MCU to determine the source of an interrupt request ($\overline{\text{IRQ}}$). When an interrupt event occurs, the corresponding flag in the interrupt status register is set to logic high. If the enable bit for this flag is Logic 1 in the interrupt enable register, the $\overline{\text{IRQ}}$ logic output will go active low. When the MCU services the interrupt, it must first carry out a read from the interrupt status register to determine the source of the interrupt.

Table 12.

Bit Location	Interrupt Flag	Description
0	AEHF	Indicates that an interrupt occurred because the active energy register, AENERGY, is more than half full.
1	SAG	Indicates that an interrupt was caused by a sag on the line voltage.
2	CYCEND	Indicates the end of energy accumulation over an integral number of half line cycles, as defined by the content of the LINECYC register—see the Line Cycle Energy Accumulation Mode section.
3	WSMP	Indicates that new data is present in the waveform register.
4	ZX	This status bit is set to 1 on the rising and falling edge of the voltage waveform, see the Zero-Crossing Detection section.
5	TEMP	Indicates that a temperature conversion result is available in the temperature register.
6	RESET	Indicates the end of a reset for software and hardware resets. The corresponding enable bit has no function in the interrupt enable register, i.e., this status bit is set at the end of a reset, but cannot be enabled to cause an interrupt.
7	AEOF	Indicates that the active energy register has overflowed.
8	PKV	Indicates that the waveform sample from Channel 2 has exceeded the VPKLVL value.
9	PKI	Indicates that the waveform sample from Channel 1 has exceeded the IPKLVL value.
10	VAEHF	Indicates that an interrupt occurred because the apparent energy register, VAENERGY, is more than half full.
11	VAEOF	Indicates that the apparent energy register has overflowed.
12	ZXTO	Indicates that an interrupt was caused by a missing zero crossing on the line voltage for a specified number of line cycles—see the Zero-Crossing Timeout section.
13	PPOS	Indicates that the power has gone from negative to positive.
14	PNEG	Indicates that the power has gone from positive to negative.
15	RESERVED	Reserved.

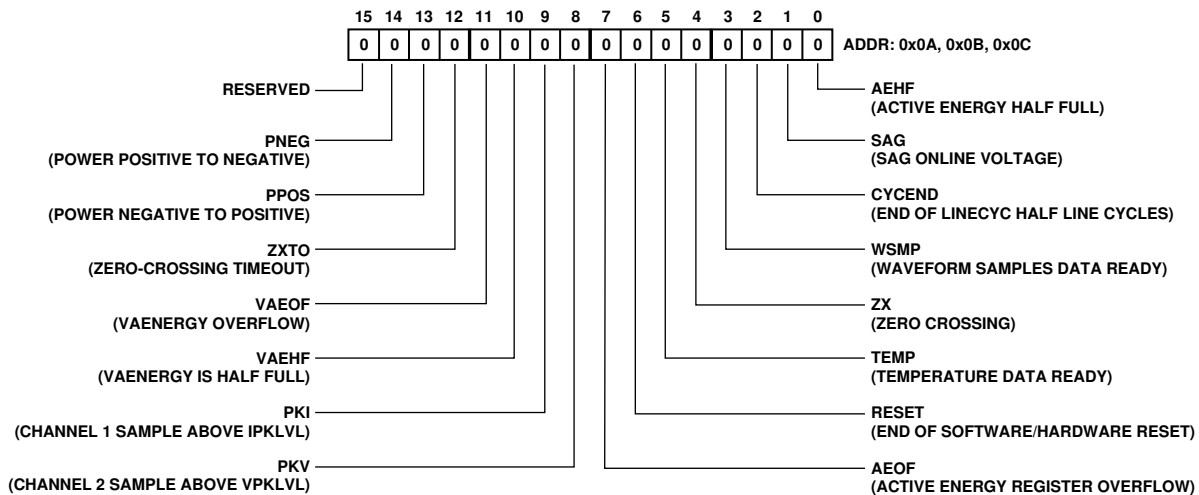

Figure 87. Interrupt Status/Interrupt Enable Register

CH1OS REGISTER (0x0D)

The CH1OS register is an 8-bit, read/write enabled register. The MSB of this register is used to switch the digital integrator on and off in Channel 1, and Bits 0 to 5 indicate the amount of offset correction in Channel 1. Table 13 summarizes the function of this register.

Table 13. CH1OS Register

Bit Location	Bit Mnemonic	Description
0 to 5	OFFSET	The 6 LSBs of the CH1OS register control the amount of dc offset correction in the Channel 1 ADC. The 6-bit offset correction is sign and magnitude coded. Bits 0 to 4 indicate the magnitude of the offset correction. Bit 5 shows the sign of the offset correction. A 0 in Bit 5 means the offset correction is positive, and a 1 indicates the offset correction is negative.
6	Not Used	This bit is not used.
7	INTEGRATOR	This bit is used to activate the digital integrator on Channel 1. The digital integrator is switched on by setting this bit. This bit is set to 0 by default.

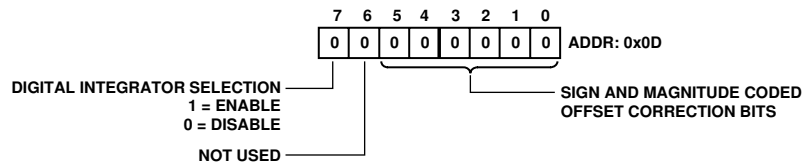
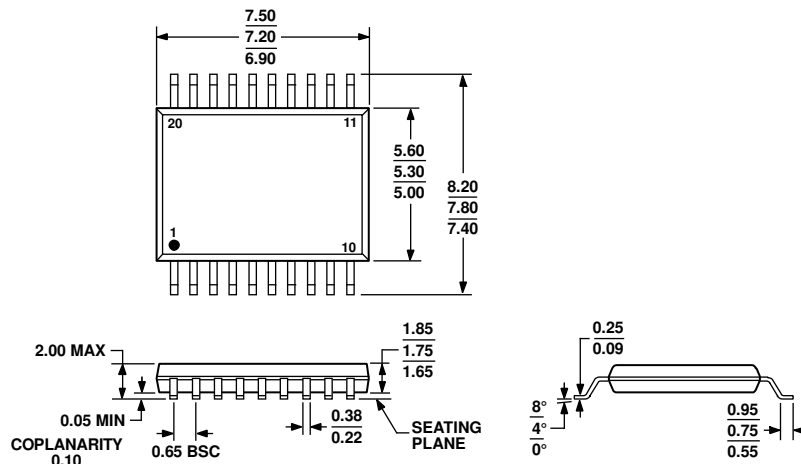

Figure 88. Channel 1 Offset Register

OUTLINE DIMENSIONS



COMPLIANT TO JEDEC STANDARDS MO-150-AE

Figure 89. 20-Lead Shrink Small Outline Package [SSOP] (RS-20)

Dimensions shown in millimeters

0661106-A

ORDERING GUIDE

Model ¹	Temperature Range	Package Description	Package Option
ADE7763ARSZ	-40°C to +85°C	20-Lead SSOP	RS-20
ADE7763ARSZRL	-40°C to +85°C	20-Lead SSOP	RS-20
EVAL-ADE7763ZEB		Evaluation Board	

¹ Z = RoHS Compliant Part.

NOTES