

18W AccuSwitch™ Quasi-Resonant PWM Controller with Integrated 900V Power BJT

1 Description

The iW1822 integrates a high performance AC/DC power supply controller using digital control technology and a power BJT switch in one package to enable compact peak current mode PWM flyback power supplies. The device operates in quasi-resonant mode and features multiple key protection features, allowing designs with improved efficiency and lower EMI, while lowering the bill of material cost.

The iW1822 features a distinctive soft-start scheme, which allows for fast and yet smooth start-up with both small and large capacitive loads. It removes the need for a secondary feedback circuit while achieving excellent line and load regulation. It also eliminates the need for loop compensation components while maintaining stability across all operating conditions. The pulse-by-pulse waveform analysis allows for fast dynamic load response. The built-in power limit function enables optimized transformer design for a wide input voltage range.

Renesas' innovative, proprietary technology ensures that power supplies built with the iW1822 can achieve both the highest average efficiency and less than 30mW no-load power consumption. And, the iW1822 can start-up into a wide range of capacitive loads at 5V to 12V or higher output voltages, making it ideal for networking, set-top box and home appliance power supply applications.

2 Features

- Optimized for 12V/1.5AAC/DC adapters with < 30mW no-load power consumption at 230V_{AC} and fast dynamic response
- **AccuSwitch™** technology – integrated 900V bipolar junction transistor (BJT)
- Adaptively controlled soft-start enables fast and smooth start-up for a wide range of capacitive loads (from 330μF to 6,000μF)
- Very tight constant voltage and constant current regulation over entire operating range
- **PrimAccurate™** primary-side feedback eliminates optocoupler and simplifies design
- **EZ-EMI™** design enhances manufacturability
- Intrinsically low common mode noise
- Optimized 72kHz maximum PWM switching frequency achieves best size and efficiency
- Adaptive multi-mode PWM/PFM control improves efficiency
- Quasi-resonant operation for highest overall efficiency
- Dynamic base current control
- No external loop compensation components required
- Built-in single-point protections against output short-circuit, output low impedance, and output overvoltage
- Built-in over-temperature protection (OTP)
- No audible noise over entire operating range

3 Applications

- Network power adapters for ADSL, wireless access
- AC/DC adaptor for set top box
- AC/DC power supplies for home appliances and industrial applications

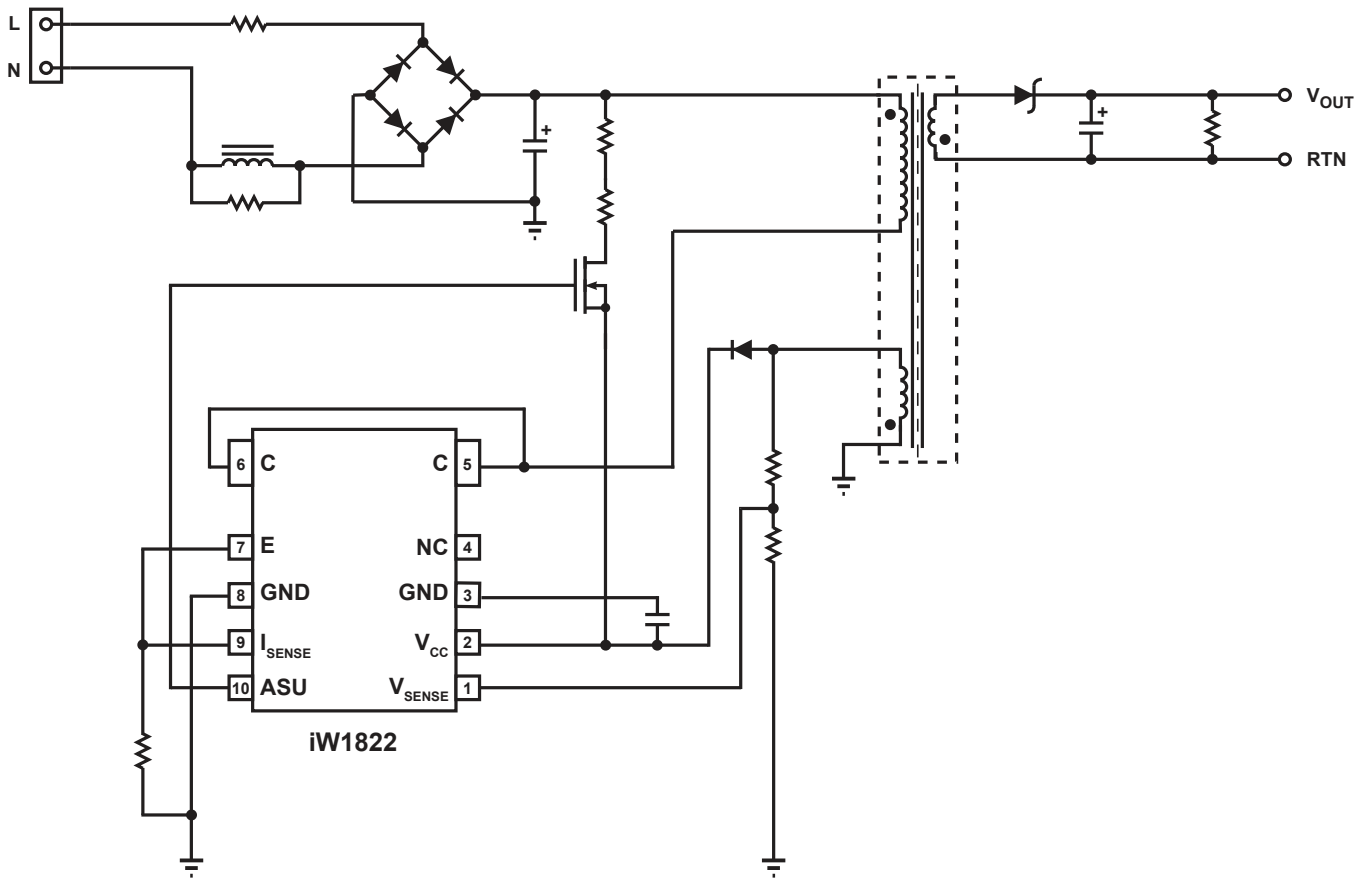

Figure 3.1 : iW1822 Typical Application Circuit

WARNING:

The iW1822 is intended for high voltage AC/DC offline applications. Contact with live high voltage offline circuits or improper use of components may cause lethal or life threatening injuries or property damage. Only qualified professionals with safety training and proper precaution should operate with high voltage offline circuits.

iW1822 Output Power Table at Universal Input (85V_{AC}–264V_{AC})

Condition	Open Frame ¹
Output Power (W) ²	18

Notes:

- Note 1. Maximum practical continuous output power measured at open frame ambient temperature of 50°C while minimum bulk capacitor voltage is kept above 90V (test unit is placed in a non-ventilated environment).
- Note 2. The output power can vary depending on the power supply system designs and operating conditions.

4 Pinout Description

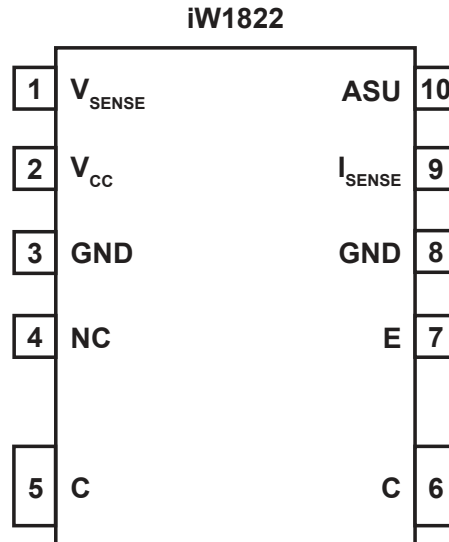

Figure 4.1 : 10-Lead SOIC Batwing Package

Pin Number	Pin Name	Type	Pin Description
1	V _{SENSE}	Analog Input	Auxiliary voltage sense (used for primary-side regulation).
2	V _{CC}	Power Input	Power supply for control logic.
3	GND	Ground	Ground.
4	NC		This pin must be left floating.
5	C	BJT Collector	Collector of internal BJT.
6	C	BJT Collector	Collector of internal BJT.
7	E	BJT Emitter	Emitter of internal BJT.
8	GND	Ground	Ground.
9	I _{SENSE}	Analog Input	Primary current sense. Used for cycle-by-cycle peak current control and current limit.
10	ASU	Output	Control signal. Used for active start-up device.

5 Absolute Maximum Ratings

Absolute maximum ratings are the parameter values or ranges which can cause permanent damage if exceeded.

Parameter	Symbol	Value	Units
DC supply voltage range (pin 2, $I_{CC} = 20\text{mA max}$)	V_{CC}	-0.3 to 25.0	V
Continuous DC supply current at V_{CC} pin ($V_{CC} = 15\text{V}$)	I_{CC}	25	mA
ASU output (pin 10)		-0.3 to 19.0	V
V_{SENSE} input (pin 1, $I_{VSENSE} \leq 10\text{mA}$)		-0.7 to 4.0	V
I_{SENSE} input (pin 9)		-0.3 to 4.0	V
Collector-Base breakdown voltage	V_{CBO}	900	V
Collector-Emitter breakdown voltage	V_{CES}	900	V
Collector current (Note 1)	I_C	4	A
Collector peak current (Note 1) ($t_p < 1\text{ms}$)	I_{CM}	8	A
Maximum junction temperature	T_{JMAX}	150	°C
Operating junction temperature	T_{JOPT}	-40 to 150	°C
Storage temperature	T_{STG}	-55 to 150	°C
Electrostatic Discharge Capability (Human Body Model), JEDEC JS-001-2017	$ESD_{(HBM)}$	± 2000	V
Electrostatic Discharge Capability (Charged Device Model), JS-002-2014	$ESD_{(CDM)}$	± 1000	V
Latch-up test per JESD78E		± 100	mA

Notes:

Note 1. Limited by maximum junction temperature.

6 Thermal Characteristics

Parameter	Symbol	Value	Units
Thermal Resistance Junction-to-Ambient ¹	θ_{JA}	55.2	°C/W
Characterization Parameter Junction-to-Collector pin (pin 5 and pin 6) ²	$\Psi_{J-COLLECTOR}$	5.8	°C/W
Thermal Shutdown Threshold ³	T_{SD}	150	°C
Thermal Shutdown Recovery ³	T_{SD-R}	100	°C
Thermal Shutdown Recovery ³ (iW1822-11)	T_{SD-R}	120	°C

Notes:

Note 1. Device is mounted on a 4-layer JEDEC board with 100mm² of 70µm thick copper, in a one-cubic-foot natural convection chamber.

Note 2. $\Psi_{J-COLLECTOR}$ [Psi Junction to Collector pin] provides an estimation of the die junction temperature relative to the Collector pin [internal BJT Collector] surface temperature.

Note 3. These parameters are typical and they are guaranteed by design.

7 Physical Dimensions

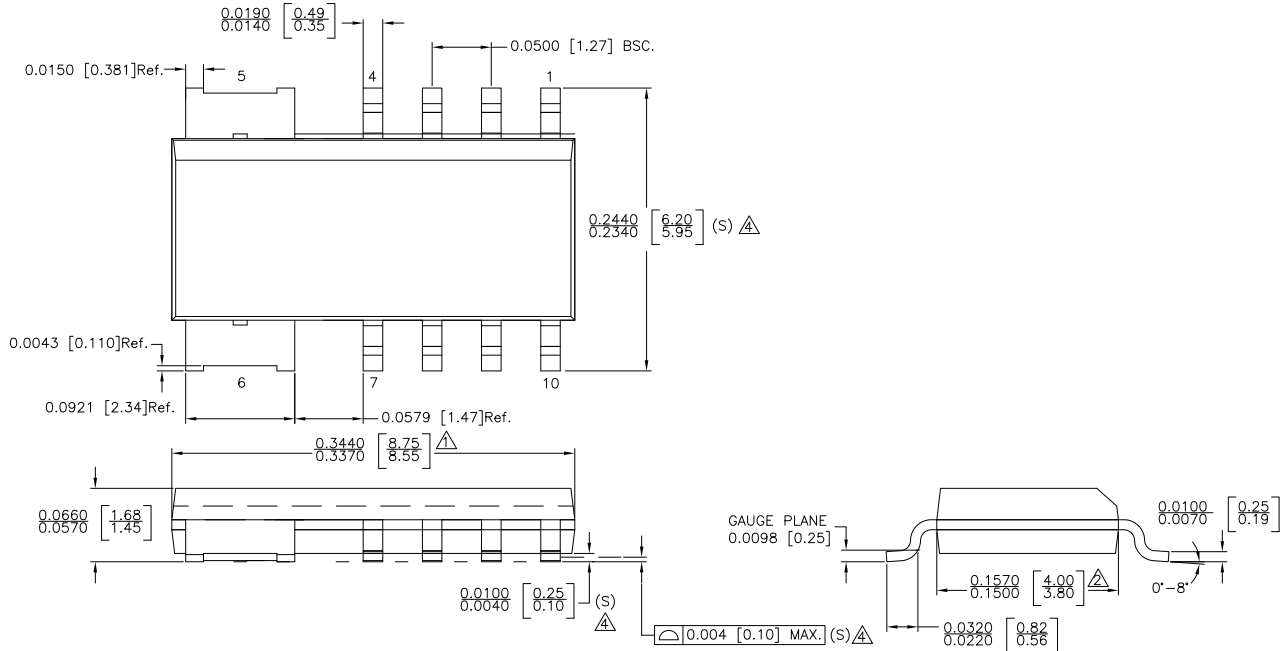

NOTE :

- △ DOES NOT INCLUDE MOLD FLASH, PROTRUSIONS OR GATE BURRS. MOLD FLASH, PROTRUSIONS AND GATE BURRS SHALL NOT EXCEED .006 INCH PER SIDE.
- △ DOES NOT INCLUDE INTER-LEAD FLASH OR PROTRUSIONS. INTER-LEAD FLASH AND PROTRUSIONS SHALL NOT EXCEED .010 INCH PER SIDE.
- 3. THIS PART IS COMPLIANT WITH JEDEC SPECIFICATION MS-012 AB.
- △ LEAD SPAN/STAND OFF HEIGHT/COPLANARITY ARE CONSIDERED AS SPECIAL CHARACTERISTIC.(S)
- 5. CONTROL DIMENSIONS IN INECHES.[mm]

STATUS: RELEASED	SCALE: DO NOT SCALE
TERMINAL FINISH: NiPdAu (PPF)	
TITLE: 10 SOIC BATWING PACKAGE OUTLINE	
REV: A	REVISION NOTE: NEW DRAWING
DATE: 29-SEP-2015	

8 Ordering Information

Part no.	Options	Package	Description
iW1822-00	Cable Comp = 0mV, OTP recovery threshold = 100°C	SO-10 Batwing	Tape & Reel ¹
iW1822-01	Cable Comp = 150mV, OTP recovery threshold = 100°C	SO-10 Batwing	Tape & Reel ¹
iW1822-11	Cable Comp = 150mV, OTP recovery threshold = 120°C	SO-10 Batwing	Tape & Reel ¹

Note 1: Tape & Reel packing quantity is 2,500/reel. Minimum packing quantity is 2,500.

18W AccuSwitch™ Quasi-Resonant PWM Controller with Integrated 900V Power BJT

IMPORTANT NOTICE AND DISCLAIMER

RENESAS ELECTRONICS CORPORATION AND ITS SUBSIDIARIES (“RENESAS”) PROVIDES TECHNICAL SPECIFICATIONS AND RELIABILITY DATA (INCLUDING DATASHEETS), DESIGN RESOURCES (INCLUDING REFERENCE DESIGNS), APPLICATION OR OTHER DESIGN ADVICE, WEB TOOLS, SAFETY INFORMATION, AND OTHER RESOURCES “AS IS” AND WITH ALL FAULTS, AND DISCLAIMS ALL WARRANTIES, EXPRESS OR IMPLIED, INCLUDING, WITHOUT LIMITATION, ANY IMPLIED WARRANTIES OF MERCHANTABILITY, FITNESS FOR A PARTICULAR PURPOSE, OR NON-INFRINGEMENT OF THIRD PARTY INTELLECTUAL PROPERTY RIGHTS.

These resources are intended for developers skilled in the art designing with Renesas products. You are solely responsible for (1) selecting the appropriate products for your application, (2) designing, validating, and testing your application, and (3) ensuring your application meets applicable standards, and any other safety, security, or other requirements. These resources are subject to change without notice. Renesas grants you permission to use these resources only for development of an application that uses Renesas products. Other reproduction or use of these resources is strictly prohibited. No license is granted to any other Renesas intellectual property or to any third party intellectual property. Renesas disclaims responsibility for, and you will fully indemnify Renesas and its representatives against, any claims, damages, costs, losses, or liabilities arising out of your use of these resources. Renesas’ products are provided only subject to Renesas’ Terms and Conditions of Sale or other applicable terms agreed to in writing. No use of any Renesas resources expands or otherwise alters any applicable warranties or warranty disclaimers for these products.

© 2022 Renesas Electronics Corporation. All rights reserved.

RoHS Compliance

Dialog Semiconductor’s suppliers certify that its products are in compliance with the requirements of Directive 2011/65/EU of the European Parliament on the restriction of the use of certain hazardous substances in electrical and electronic equipment. RoHS certificates from our suppliers are available on request.

(Rev.1.0 Mar 2020)

Corporate Headquarters

TOYOSU FORESIA, 3-2-24 Toyosu
Koto-ku, Tokyo 135-0061, Japan
www.renesas.com

Contact Information

For further information on a product, technology, the most up-to-date version of a document, or your nearest sales office, please visit:
www.renesas.com/contact/

Trademarks

Renesas and the Renesas logo are trademarks of Renesas Electronics Corporation. All trademarks and registered trademarks are the property of their respective owners.