

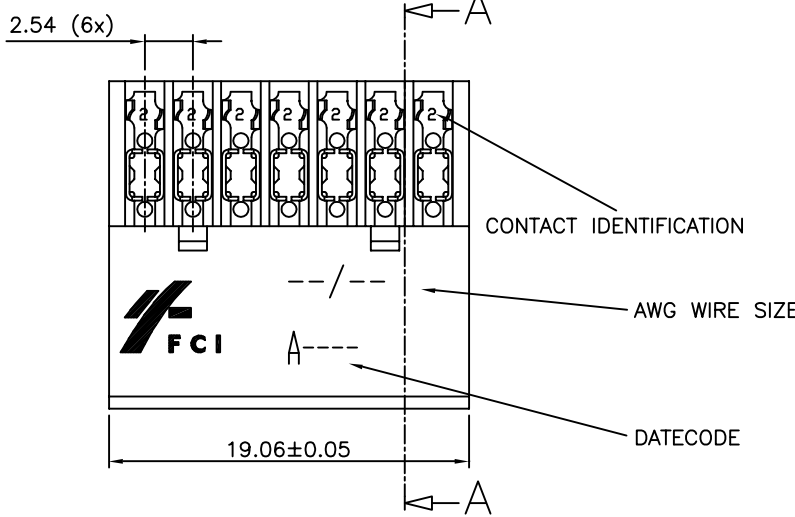

FCIconnect.com

Copyright FCI

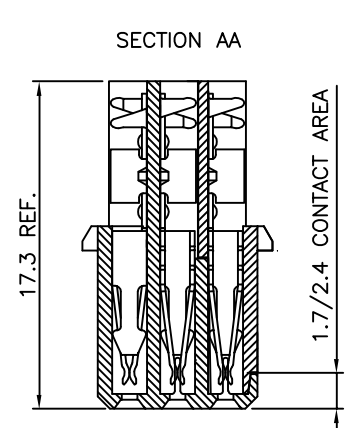

PRODUCT NUMBER BPS8B21FLD-C0--LF

WITH "LF" SUFFIX LEAD FREE OR RoHS COMPATIBLE PRODUCT

WIRE ACCOMODATION			CONTACT PLATING	
PRODUCT NUMBER	WIRE SIZE	CONTACT IDENTIFICATION	PLATING CODE	PERFORMANCE LEVEL PER DIN41612
BPS8B21FLD0C0--LF	AWG28/30	0	Z0	CLASS 3
BPS8B21FLD2C0--LF	AWG24/26	2	Z1	CLASS 2
			E9	CLASS 1

NOTES:-

1. THE "LF" PRODUCTS MEET EUROPEAN UNION DIRECTIVES AND OTHER COUNTRY REGULATIONS AS DESCRIBED IN GS-22-008
2. LEAD FREE OR RoHS DIRECTIVE LABELING TO BE PROVIDED AS PER GS-14-920 FOR RoHS COMPATIBLE VERSION.

PERFORMANCES CHARACTERISTICS

VOLTAGE RATING : 250 VAC (rms)

CURRENT RATING : 1,5 A AT 25 °C, 1 A AT 70 °C.

INSULATION RESISTANCE : 1000MΩINITIAL, 100MΩMIN. AFTER TEST

DIELECTRIC WITH-

STANDING VOLTAGE : 1000 VAC (rms).

CONTACT RESISTANCE : 15mΩMAX. INITIAL, 5mΩMAX. RISE OF INITIAL VALUE AFTER TEST.

OPERATING TEMPERATURE*: -40 °C TO +125 °C.

INSERTION FORCE : 1 N MAX./CONTACT.

WITHDRAWAL FORCE : 0,2 N MIN./CONTACT.

*DEPENDING ON THE CABLE, THE MAX. TEMPERATURE CAN BE LOWER. FOR STANDARD PVC INSULATED CABLE : 105 °C MAX.

CONSTRUCTION

BODY MATERIAL : GLASS-REINFORCED THERMOPLASTIC (UL94V-0).

COVER MATERIAL : POLYESTER (PBTP), COLOUR : BLACK.

CONTACT MATERIAL : PHOSPHOR BRONZE.

CONTACT FINISH : Au OVER Ni IN CONTACT AREA
Sn (MATT TIN) ON I.D.C. TERMINAL

Z0 : PERFORMANCE LEVEL PER DIN41612 CLASS 3
Z1 : PERFORMANCE LEVEL PER DIN41612 CLASS 2
E9 : PERFORMANCE LEVEL PER DIN41612 CLASS 1
OTHERS : CONSULT FCI

TIE-WRAP : OPTIONAL PART N°. TF3.

PART NUMBERS

BPS8B21FLD0C0--LF CONNECTOR FOR WIRE SIZE AWG28, AWG30.
(CONTACT IDENTIFICATION : 0).

BPS8B21FLD2C0--LF CONNECTOR FOR WIRE SIZE AWG24, AWG26
(CONTACT IDENTIFICATION : 2).

AWG WIRE SIZE MARKING

BPS8B21FLD0C0--LF : 28/30.

BPS8B21FLD2C0--LF : 24/26.

DATECODE MARKING

A + YEAR & WEEKCODE, EXAMPLE : A9950.

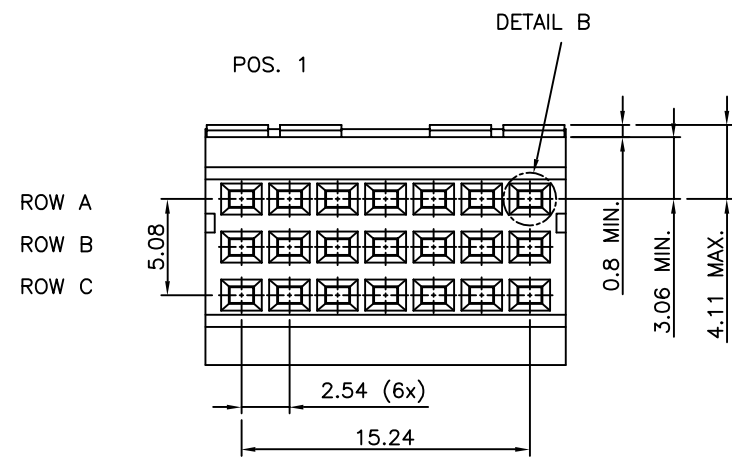
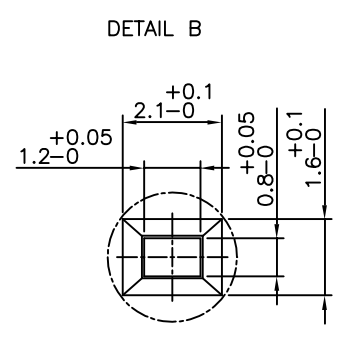
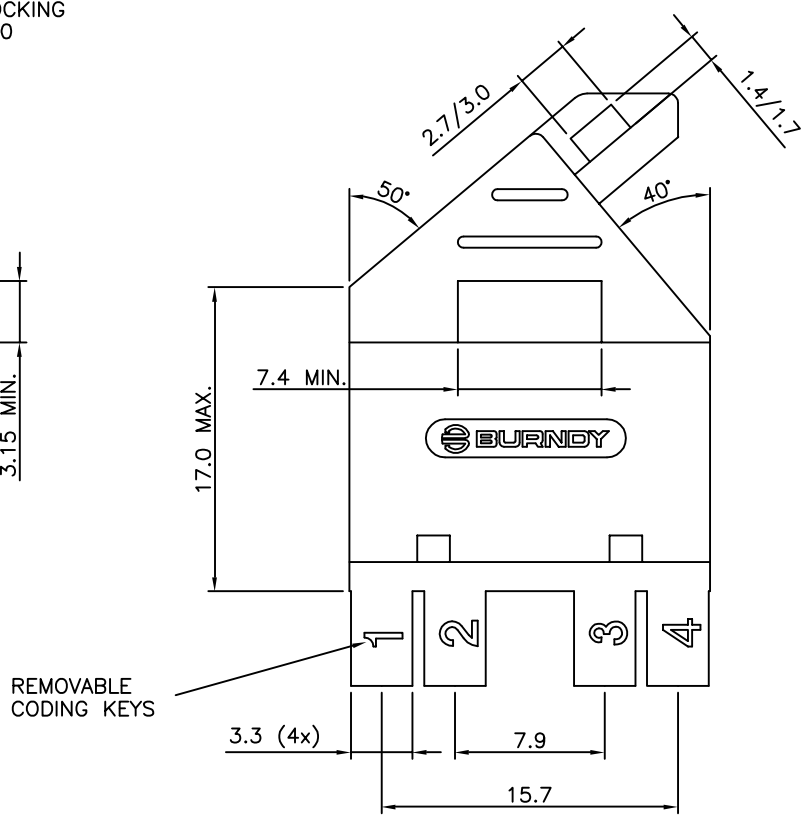
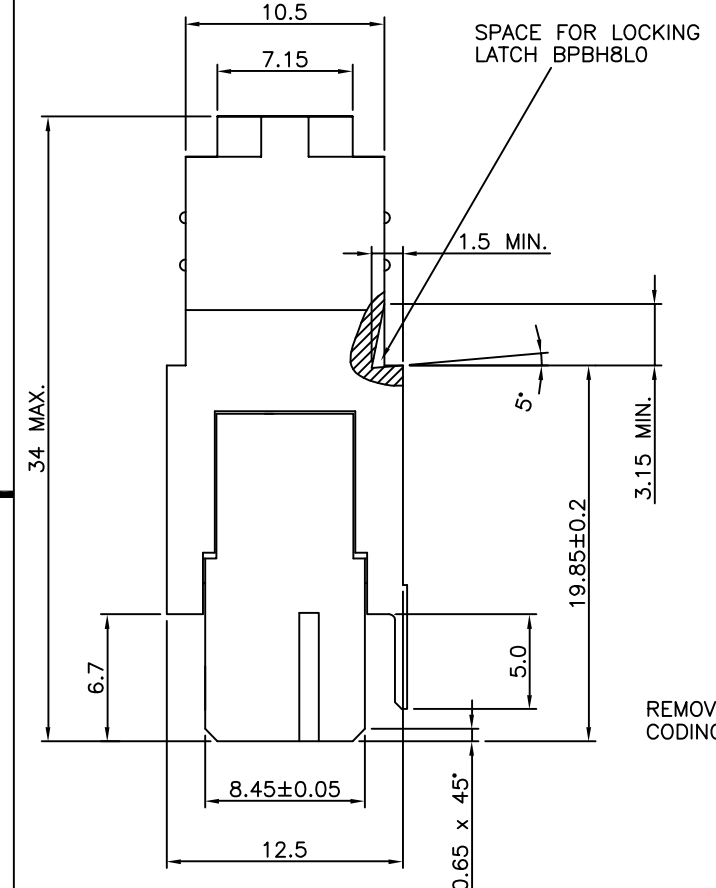
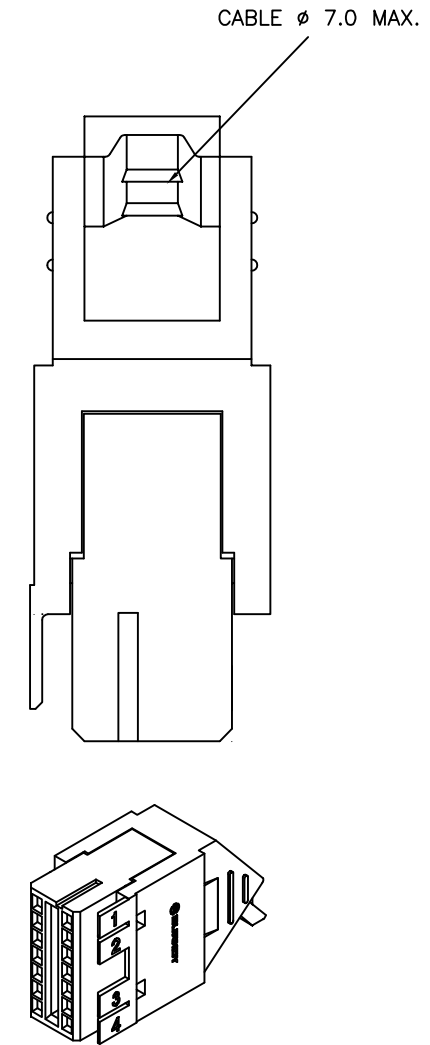

mat'l. code		surface		tolerance		projection		product family	
SEE NOTE		ISO 1302 ✓		ISO 406 ISO 1101				BPS8	
ltr		ecn no		dr		date		title	
A		F00819		DLE		2000-10-23		ASSY BPS8	
B		105-0123		MINI		2005-07-27		21 POS. A,B,C LOADED	
C		106-0067		MINI		2006-06-01			
D		107-0081		KR		2007-06-28			
sheet index		revision		D		D		D	
		sheet		1		2		3	



PRODUCT NUMBER BPS8B21FLD-00--LF

WITH "LF" SUFFIX LEAD FREE OR RoHS COMPATIBLE PRODUCT

NOTES:-
 1. THE "LF" PRODUCTS MEET EUROPEAN UNION DIRECTIVES AND OTHER COUNTRY REGULATIONS AS DESCRIBED IN GS-22-008
 2. LEAD FREE OR RoHS DIRECTIVE LABELING TO BE PROVIDED AS PER GS-14-920 FOR RoHS COMPATIBLE VERSION.

WIRE ACCOMODATION

PRODUCT NUMBER	WIRE SIZE	CONTACT IDENTIFICATION
BPS8B21FLD000--LF	AWG28/30	0
BPS8B21FLD200--LF	AWG24/26	2

CONTACT PLATING

PLATING CODE	PERFORMANCE LEVEL PER DIN41612
Z0	CLASS 3
Z1	CLASS 2
E9	CLASS 1

PERFORMANCES CHARACTERISTICS

VOLTAGE RATING : 250 VAC (rms)
 CURRENT RATING : 1,5 A AT 25 °C, 1 A AT 70 °C.
 INSULATION RESISTANCE : 1000MΩINITIAL, 100MΩMIN. AFTER TEST
 DIELECTRIC WITH-
 STANDING VOLTAGE : 1000 VAC (rms).
 CONTACT RESISTANCE : 15 mΩMAX. INITIAL, 5mΩMAX. RISE OF INITIAL VALUE AFTER TEST.
 OPERATING TEMPERATURE*: -40 °C TO +125 °C.
 INSERTION FORCE : 1 N MAX./CONTACT.
 WITHDRAWAL FORCE : 0,2 N MIN./CONTACT.
 *DEPENDING ON THE CABLE, THE MAX. TEMPERATURE CAN BE LOWER. FOR STANDARD PVC INSULATED CABLE : 105 °C MAX.

CONSTRUCTION

BODY MATERIAL : GLASS-REINFORCED THERMOPLASTIC (UL94V-0).
 CONTACT MATERIAL : PHOSPHOR BRONZE.
 CONTACT FINISH : Au OVER Ni IN CONTACT AREA
 Sn (MATT TIN) ON I.D.C. TERMINAL

Z0 : PERFORMANCE LEVEL PER DIN41612 CLASS 3
 Z1 : PERFORMANCE LEVEL PER DIN41612 CLASS 2
 E9 : PERFORMANCE LEVEL PER DIN41612 CLASS 1
 OTHERS : CONSULT FCI

PART NUMBERS

BPS8B21FLD000--LF CONNECTOR FOR WIRE SIZE AWG28, AWG30.
 (CONTACT IDENTIFICATION : 0).
 BPS8B21FLD200--LF CONNECTOR FOR WIRE SIZE AWG24, AWG26
 (CONTACT IDENTIFICATION : 2).

AWG WIRE SIZE MARKING

BPS8B21FLD000--LF : 28/30
 BPS8B21FLD200--LF : 24/26

DATECODE MARKING

A + YEAR & WEEKCODE, EXAMPLE : A9950.

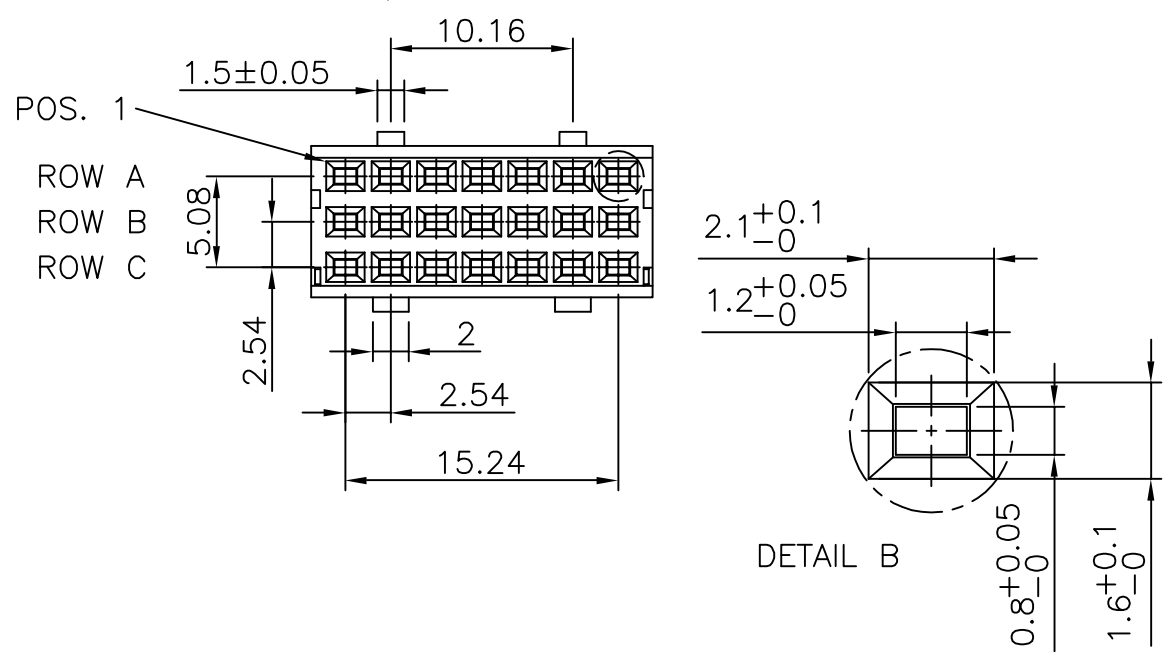
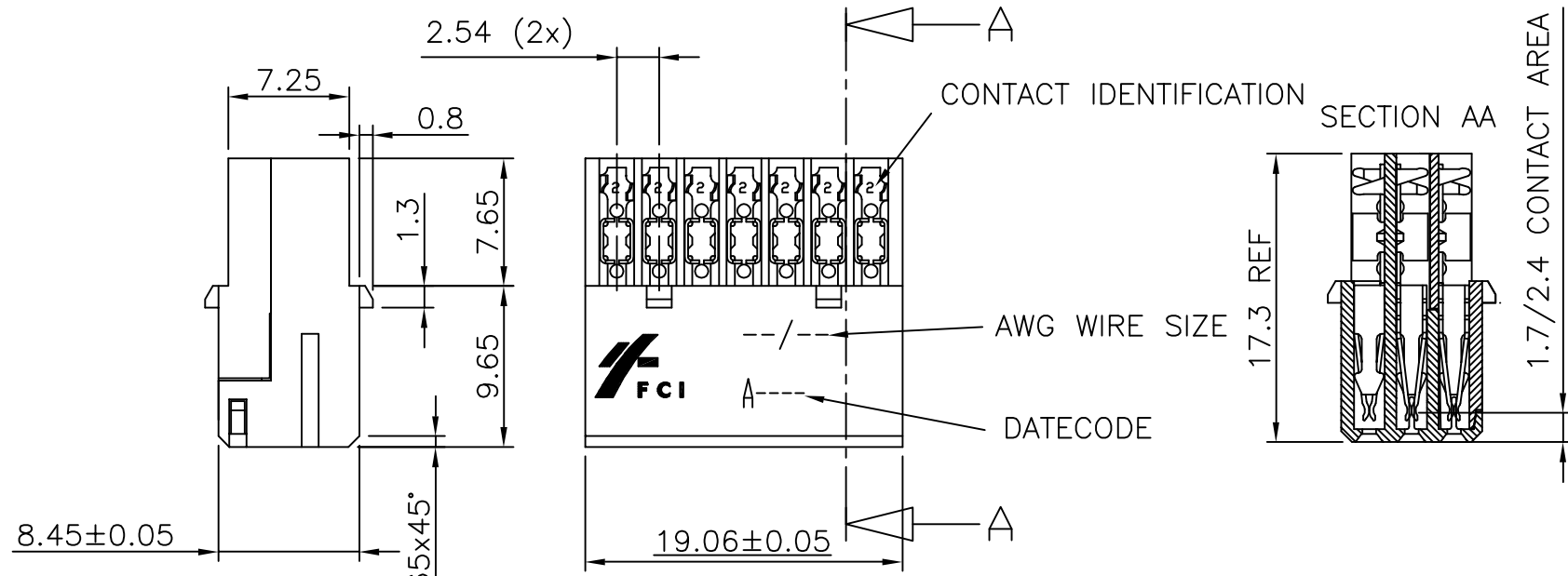

mat'l. code		surface		tolerance		projection		product family	
SEE NOTE		ISO 1302 ✓		ISO 406 ISO 1101		mm		BPS8	
tolerances unless otherwise specified		angles		linear		scale -		title	
A F00819 DLE 2000-10-19		±1°		0.1±0.2		mm		ASSY BPS8	
B 105-0123 MINI 2005-07-27		±1'		0.01±0.1		mm		21 POS. A,B,C LOADED	
C 106-0067 MINI 2006-06-01		±1'		0.01±0.1		mm		dwg no	
D 107-0081 KR 2007-06-28		±1'		0.01±0.1		mm		sheet 2 of 3	
sheet index		revision sheet		dr D.LEGRAND 2000-10-19		FCI		55355	
				enr J.F.NOTTEAU 2000-10-19				A3	
				chr RAKHEE GEORGE 2007-06-28				type	
				appd RAKHEE GEORGE 2007-06-28				Product Customer Drawing	

SECTION AA

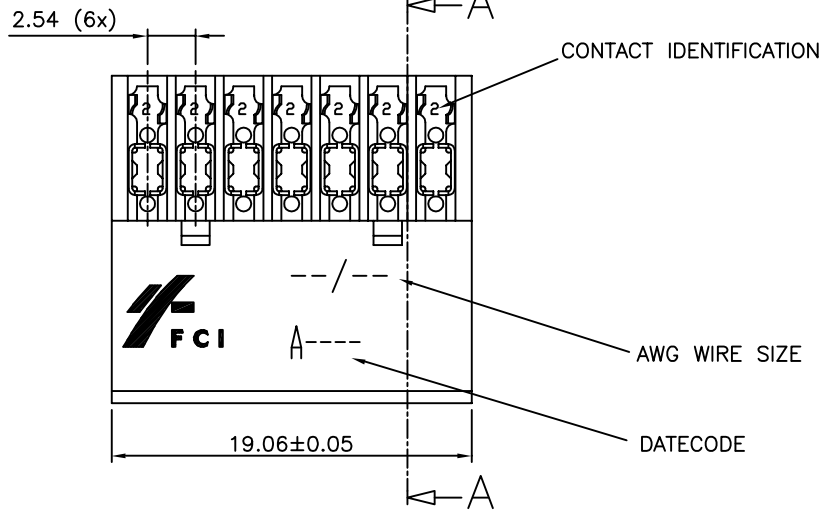
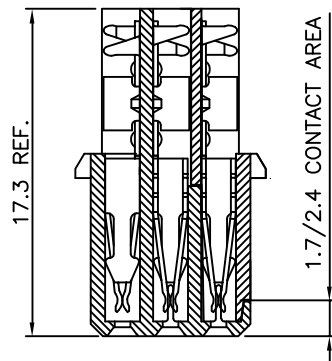

NOTES:-
1. THE "LF" PRODUCTS MEET EUROPEAN UNION DIRECTIVES AND OTHER COUNTRY REGULATIONS AS DESCRIBED IN GS-22-008
2. LEAD FREE OR RoHS DIRECTIVE LABELING TO BE PROVIDED AS PER GS-14-920 FOR RoHS COMPATIBLE VERSION.

PRODUCT NUMBER BPS8B21FLD-MO--LF
WITH "LF" SUFFIX LEAD FREE OR RoHS COMPATIBLE PRODUCT

WIRE ACCOMODATION		
PRODUCT NUMBER	WIRE SIZE	CONTACT IDENTIFICATION
BPS8B21FLD0M0--LF	AWG28/30	0
BPS8B21FLD2M0--LF	AWG24/26	2

CONTACT PLATING	
PLATING CODE	PERFORMANCE LEVEL PER DIN41612
Z0	CLASS 3
Z1	CLASS 2
E9	CLASS 1

PERFORMANCES CHARACTERISTICS
 VOLTAGE RATING : 250 VAC (rms)
 CURRENT RATING : 1,5 A AT 25 °C, 1 A AT 70 °C.
 INSULATION RESISTANCE : 1000MΩINITIAL, 100MΩMIN. AFTER TEST
 DIELECTRIC WITHSTANDING VOLTAGE : 1000 VAC (rms).
 CONTACT RESISTANCE : 15mΩMAX. INITIAL, 5mΩMAX. RISE OF INITIAL VALUE AFTER TEST.
 OPERATING TEMPERATURE*: -40 °C TO +125 °C.
 INSERTION FORCE : 1 N MAX./CONTACT.
 WITHDRAWAL FORCE : 0,2 N MIN./CONTACT.

*DEPENDING ON THE CABLE, THE MAX. TEMPERATURE CAN BE LOWER.
 FOR STANDARD PVC INSULATED CABLE : 105 °C MAX.

CONSTRUCTION
 BODY MATERIAL : GLASS-REINFORCED THERMOPLASTIC (UL94V-0).
 COVER MATERIAL : Ni PLATED ABS MATERIAL
 CONTACT MATERIAL : PHOSPHOR BRONZE.
 CONTACT FINISH : Au OVER Ni IN CONTACT AREA
 Sn (MATT TIN) ON I.D.C. TERMINAL
 Z0 : PERFORMANCE LEVEL PER DIN41612 CLASS 3
 Z1 : PERFORMANCE LEVEL PER DIN41612 CLASS 2
 E9 : PERFORMANCE LEVEL PER DIN41612 CLASS 1
 OTHERS : CONSULT FCI

TIE-WRAP : OPTIONAL (PART N°. TF3)
 PART NUMBERS
 BPS8B21FLD0M0--LF CONNECTOR FOR WIRE SIZE AWG28, AWG30.
 (CONTACT IDENTIFICATION : 0).
 BPS8B21FLD2M0--LF CONNECTOR FOR WIRE SIZE AWG24, AWG26
 (CONTACT IDENTIFICATION : 2).

AWG WIRE SIZE MARKING
 BPS8B21FLD0M0--LF : 28/30.
 BPS8B21FLD2M0--LF : 24/26.
 DATECODE MARKING
 A + YEAR & WEEKCODE, EXAMPLE : A9950.

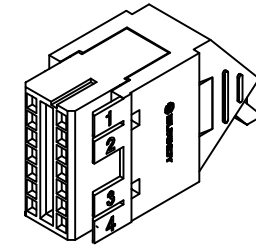
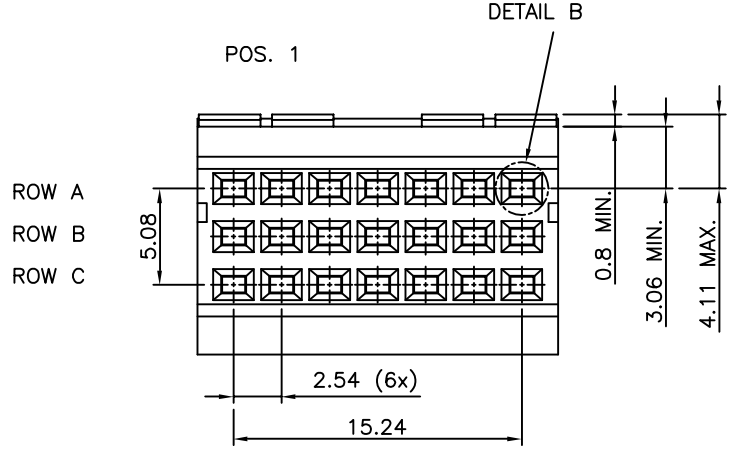
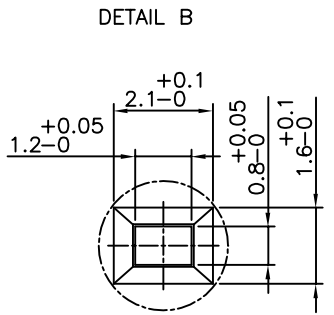
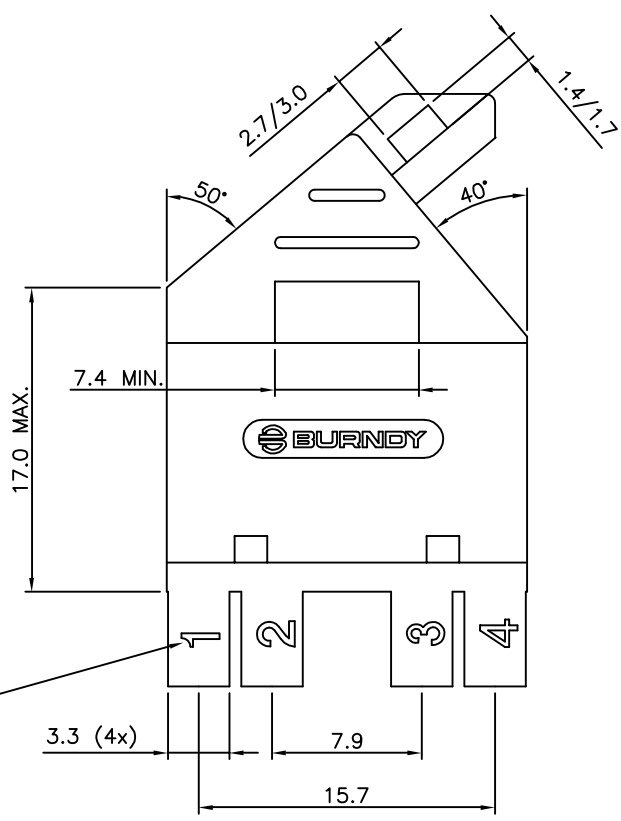
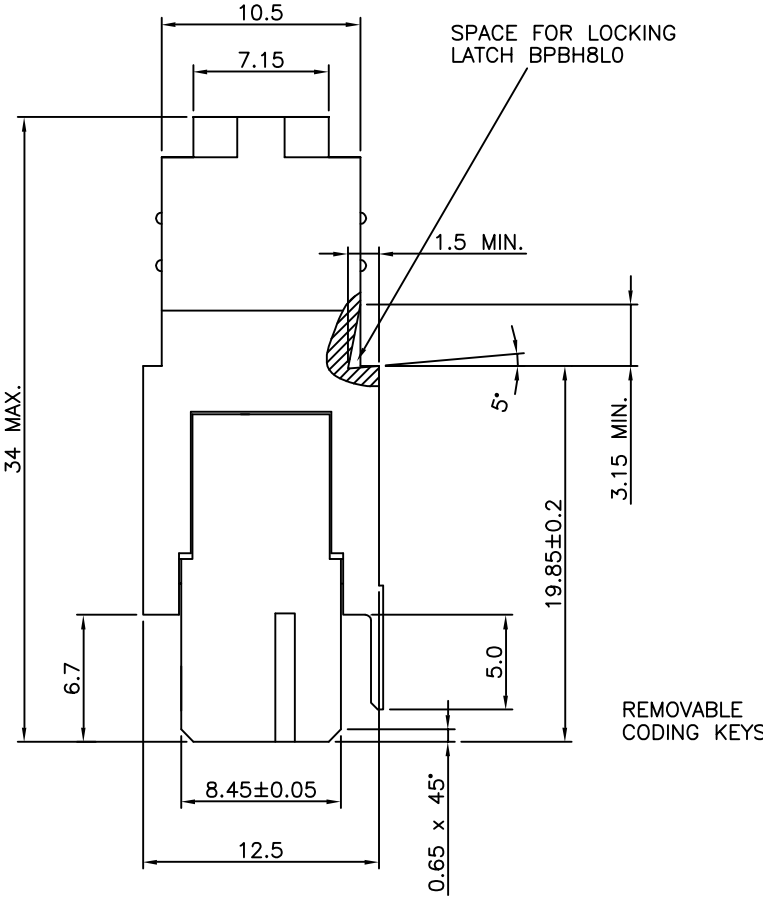
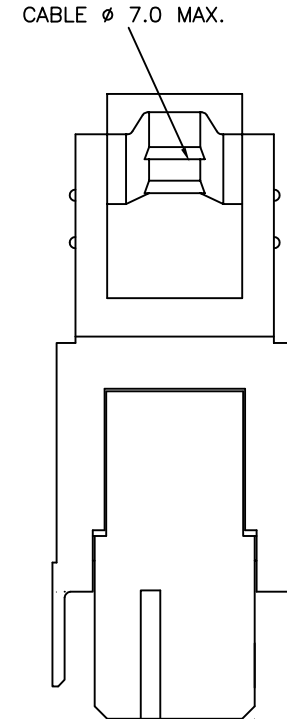

mat'l. code		surface		tolerance		projection		product family	
SEE NOTE		ISO 1302 ✓		ISO 406 ISO 1101		mm		BPS8	
tolerances unless otherwise specified		angles		linear		mm		title	
A F00819 DLE 2000-10-23		0.1±0.2		0.01±0.1		mm		ASSY BPS8	
B I05-0123 MINI 2005-07-27		±1°		±1°		mm		21 POS. A,B,C LOADED	
C I06-0067 MINI 2006-06-01		±1°		±1°		mm		dwg no	
D I07-0081 KR 2007-06-28		D.LEGRAND		2000-10-23		mm		sheet 3 of 3 size	
		enr		J.F.NOTTEAU		mm		55355 A3	
		chr		RAKHEE GEORGE		mm		type	
		appd		RAKHEE GEORGE		mm		Product Customer Drawing	
sheet index		revision sheet							



Copyright FCI