

# ODB17567 Series with PWM and Tach

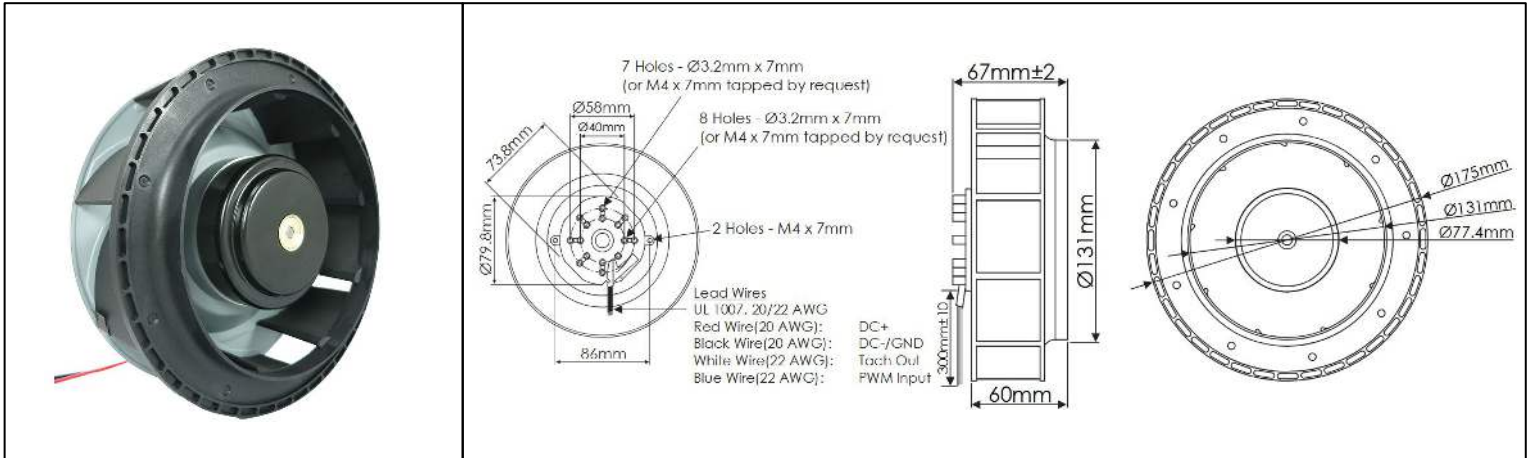

DC Centrifugal Fans - 12, 24, 48V  
175mm x 67mm (6.9" x 2.6")



<b>Frame</b>	Die Cast Aluminum, Natural Finish	<b>Operating Temperature</b> -20°C ~ +65°C <b>Storage Temperature</b> -20°C ~ +75°C <b>Life Expectancy</b> 90,000 Hours (L10 at 35°C) <b>Installed Options</b> PWM Speed Control Input Open Collector Tach Output <b>Available Options</b> Intake Duct Ring P/N: DR1719D Alarm Output <b>Weight:</b> 3.63 lbs
<b>Impeller</b>	UL94 V-0 PA66 Plastic, SEEC Steel Impeller Base	
<b>Connection</b>	4x Lead Wires, 20/22 AWG	
<b>Motor</b>	Brushless DC, Auto Cutoff, Auto Restart, Electronically Protected, Polarity Protected	
<b>Bearing System</b>	Ball Bearings	
<b>Dielectric Strength</b>	500VDC/min, <1mA	
<b>Insulation Resistance</b>	≥10MΩ @ 500 VDC	

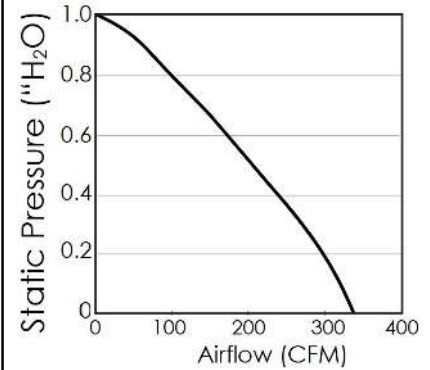

Part Number	Rated Voltage (Volts DC)	Voltage Range (Volts DC)	Input Power (Watts)	Rated Current (Amps)	Rated Speed (RPM)	Max Airflow (CFM)	Noise Level (dBA)	Max Static Pressure ("H <sub>2</sub> O)
ODB17567-12HB10A	12	11 ~ 13.8	51	4.2	3000	337	65	1.07
ODB17567-24HB10A	24	22 ~ 26	51	2.1	3000	337	65	1.07
ODB17567-48HB10A	48	40 ~ 52	53	1.1	3000	337	65	1.07

